

LEGUÁN[®] 190

Operator and Service manual



TABLE OF CONTENTS

1. INTRODUCTION AND WARRANTY CONDITIOS	4
1.1 INTRODUCTION	4
1.2 WARRANTY CONDITIONS	4
2. GENERAL INFORMATION	7
2.1 TECHNICAL SPECIFICATIONS	8
2.2 REACH DIAGRAM AND SUPPORT DIMENSIONS	9
2.3 SIGNS AND DECALS	10
3. SAFETY INSTRUCTIONS	11
3.1 BEFORE STARTING OPERATION	11
3.2 RISK OF TIPPING OVER	12
3.3 RISK OF FALLING	12
3.4 RISK OF COLLISION	13
3.5 RISK OF ELECTRIC SHOCK	13
3.6 RISK OF EXPLOSION/FIRE	13
3.7 DAILY INSPECTION BEFORE STARTING OPERATION	14
3.8 USE OF EMERGENCY STOP SWITCHES	14
3.9 SAFETY INSTRUCTIONS FOR DRIVE CONTROL	14
3.10 DEFINING THE GRADIENT OF THE SLOPE	14
4. CONTROLS AND SWITCHES	15
4.1 CONTROLS IN PLATFORM	15
4.1.1 PLATFORM OVERLOAD INDICATOR LIGHT	16
4.1.2 DYNAMIC OUTREACH CONTROL SIGNAL LIGHT	16
4.1.3 FAULT LIGHT	16
4.1.4 INCLINATION SENSOR INDICATOR LIGHT	17
4.1.5 BOOM CENTER POSITION INDICATOR (SLEWING)	17
4.1.6 BOOM TRANSPORT SUPPORT INDICATOR LIGHT	17
4.1.7 LOW FUEL LEVEL INDICATOR	18
4.2 LOWER CONTROLS PANEL	18
4.3 WIRELESS REMOTE CONTROL (OPTION)	19
4.4 EMERGENCY LOWERING BUTTON AT GROUND LEVEL (OPTION)	20
4.5 230 V CONNECTION AND SWITCHES (OPTION)	20
5. OPERATION	21
5.1 STARTING THE COMBUSTION ENGINE / ELECTRIC MOTOR	21
5.1.1 COMBUSTION ENGINE	21
5.1.2 ELECTRIC MOTOR	22
5.2 SPEED SELECTION SWITCH	22
5.3 DRIVE CONTROL	22
5.3.1 USING THE CRAWLER TRACK CHASSIS	23
5.4 OPERATION OF THE OUTRIGGERS	24
5.4.1 AUTOMATIC LEVELING	24
5.4.2 OUTRIGGER MANUAL DRIVE	24
5.5 OPERATION OF THE BOOMS	25
5.5.1 AUTOMATIC SLEWING STOP FUNCTION	25
5.5.2 DEAD MAN SWITCH, BOOM USE (OPTION)	25
5.6 REMOTE CONTROL (OPTION)	26
5.7 ENDING THE OPERATION	26
5.8 ADDITIONAL INSTRUCTIONS FOR WINTER USE	26
6. EMERGENCY LOWERING AND EMERGENCY USE	27
6.1 HAND PUMP	27
6.2 ELECTRIC LOWER CONTROLS (OPTION)	27
6.3 OUTRIGGER CONTROL OVERRIDE	28
6.4 PLATFORM LOAD CONTROL AND PLATFORM EMERGENCY STOP BUTTON OVERRIDE	28

6.5	BOOM TRANSPORT POSITION MONITORING OVERRIDE	29
7.	TRANSPORTATION	30
8.	SERVICE, MAINTENANCE AND INSPECTION REGULATIONS	31
8.1	GENERAL INSTRUCTIONS	31
9.	SERVICE INSTRUCTIONS	32
9.1	SERVICE AND CHECKS, MAINTENANCE SCHEDULE	32
9.1.1	CRAWLER TRACK SPROCKET NUTS	33
9.2	FUSES	34
9.3	GREASING	35
9.3.1	GREASING OF THE SLEW RING	35
9.3.2	GREASING THE TELESCOPIC BOOM CHAIN PULLEY AND INSPECTION OF THE CHAIN	35
9.3.3	GREASING OF TELESCOPING BOOMS	36
9.3.4	GREASING OF THE POSITION SENSOR PINS ON THE OUTRIGGERS	36
9.3.5	GREASING DIAGRAM	37
9.4	HANDLING OF FUEL AND REFUELING	38
9.5	HYDRAULIC OIL AND HYDRAULIC OIL FILTER REPLACEMENT	38
9.6	HYDRAULIC OIL LEVEL	39
9.7	BATTERY CHECK	39
9.8	CHECK OF SET-UP CONTROL SYSTEM	39
9.9	WATER LEVEL CHECK	40
9.10	HYDRAULIC PRESSURES AND ADJUSTMENTS	40
9.11	PEDESTAL VALVE HOUSING	41
9.12	OVERLOAD CONTROL COMPONENTS	42
9.14	BOOM TRANSPORT SUPPORT SENSORS	43
9.15	SAFETY VALVE TEST	45
9.16	BATTERY HANDLING	46
9.17	HANDLING OF FUEL AND OIL PRODUCTS	46
10.	REPAIR INSTRUCTIONS	47
10.1	WELDING	47
11.	INSTRUCTIONS FOR TEMPORARY STORAGE	48
12.	INSTRUCTIONS FOR DISPOSING THE ACCESS PLATFORM	48
13.	TROUBLE SHOOTING	49
14.	PERFORMED SERVICE	53

Attachments:
 Hydraulic schema
 Electric diagram

Edited:
 22.11.2021
 EA

1. INTRODUCTION AND WARRANTY CONDITIOS

1.1 Introduction

LEGUAN LIFTS wants to thank you for purchasing this Leguan access platform. It is the result of Leguan's long experience in design and manufacturing of access equipment. We ask you that you read and understand the contexts of this manual completely before operating the access platform. This will improve your operating and maintenance efficiency, help avoid breakdowns and damage and extend the life of your machine.



Pay special attention to this symbol. It indicates important safety factors that require special attention. Every operator must read and understand this manual before starting operation, and the instructions in this manual must be followed. If you are lending the access platform out to somebody, make sure that he familiarizes himself with and understands these instructions. If there is anything unclear with the operation, please contact your Leguan dealer.

If spare parts are needed, use only original LEGUAN parts. They will provide your machine with the maximum life expectancy and ensure optimum safety.

It is not possible to give explicit operating instructions to all operating conditions of the machine. Therefore, the manufacturer is not responsible for any damage caused by eventual faults in this Operators Manual.

The manufacture does not accept any responsibility for consequential losses resulting from the use of this self-propelled access platform.

1.2 Warranty conditions

This product is warranted for a period of twenty-four (24) months without hour limit. In the event a fault occurs which is attributable to manufacturing or assembly defect, contact the dealer without delay.

Warranty covers manufacturing and material defects. All warranty obligations end when the warranty period ends. Warranty repair that has been started will be completed regardless of the ending date of warranty period.

A condition for the warranty is that both the buyer and the seller have accepted the delivery. If the buyer is not present when the delivery takes place and doesn't make a complaint within 14 days of delivery of this access platform, it is considered that the sale is closed and the warranty period has started.

Warranty is limited to the repair of a faulty access platform without cost at an authorized Leguan service workshop. Warranty period for parts that are changed in connection with the repair will end when the warranty period for the access platform ends. Parts that have been changed in the warranty repair will remain Leguan Lifts' property without compensation.

Warranty does not cover:

- Damages caused by wrong or negligent use of this product, or mischief.
- Any repairs or modifications to the product, performed without the prior authorization of the manufacturer.
- Damages caused by not following service and maintenance instructions.
- Adjustments, repairs and spare parts replacements caused by normal wear.
- Damages caused by excessive loads on the access platform, sudden unexpected incident, natural disaster.
- Damages caused by external mechanical or chemical reasons (paint damages, especially caused by stone chips, air and environmental pollution and strong cleaning agents)
- Eventual visible patterns or unevenness of painted surfaces.
- Warranty claims that haven't been sent to the manufacturer within 14 days from the date the buyer has noticed the defect. In all conditions the buyer shall act so that his action doesn't make the eventual defect(s) worse.

The manufacturer does not accept any responsibility for consequential losses resulting from the use of this access platform.

In the event a fault occurs which is attributable to manufacturing or assembly defect, contact the dealer without delay.

ALKUPERÄINEN EY-VAATIMUSTENMUKAISUUSVAKUUTUS ORIGINAL EC DECLARATION OF CONFORMITY FOR MACHINERY

TÄTEN VAKUUTAMME, ETTÄ
HEREWITH DECLARES THAT

HENKILÖNOSTIN AERIAL PLATFORM	LEGUAN	NIMELLISKUORMA NOMINAL LOAD	230 kg
MALLI MODEL	L190	NOSTOKORKEUS PLATFORM HEIGHT	17,0 m
SARJANUMERO SERIAL NR	00XXXXX	VALMISTUSVUOSI YEAR OF CONSTRUCTION	20XX

**ON KONEDIREKTIIVIN 2006/42/EY ASIAAN KUULUVIEN SÄÄNNÖSTEN MUKAINEN
IS IN ACCORDANCE WITH THE REGULATIONS LAID OUT IN THE MACHINERY
DIRECTIVE: 2006/42/EC**

**KONE TÄYTTÄÄ LISÄKSI MUIDEN EY-DIREKTIIVIN VAATIMUKSET: 2004/108/EY THE
MACHINE ALSO FULFILLS THE REQUIREMENTS LAID OUT IN THE DIRECTIVES
2004/108/EY**

**SEURAAVIA EUROOPPALAISIA YHDENMUKAISIA STANDARDEJA ON SOVELLETTU
SUUNNITTELUSSA: EN280:2015
FOLLOWING EUROPEAN HARMONIZED STANDARDS ARE USED WHEN
THE MACHINERY WAS DESIGNED: EN280:2015**

Teknisen tiedoston on valtuutettu kokoamaan:
Storage address of original documents:

LEGUAN LIFTS OY
Ylötie 1, FI-33470 Ylöjärvi,
Finland

Ilmoitettu laitos / Notified Body

INSPECTA TARKASTUS OY, NB0424

Testausraportti / Test Report

No. 16038-2017

Paikka / Place, Päiväys / Date
Ylöjärvi, FINLAND

xx.xx.20xx

Valmistaja / Manufacturer:

LEGUAN LIFTS OY
Ylötie 10, FI-33470 Ylöjärvi, Finland

XXXXX

Toimitusjohtaja / Managing Director

2. GENERAL INFORMATION

LEGUAN 190 is a self-propelled Mobile Elevating Work Platform – or commonly called access platform, designed for indoor and outdoor use. An access platform is destined for lifting of persons and their equipment only. It is not allowed to use an access platform as a crane.

LEGUAN is designed and built in accordance with the international safety standards and MEWP (Mobile Elevating Work Platform) standards.

The picture below (Figure 1) shows the main parts of this access platform:

- | | | |
|---|---------------------------------------|--------------------------------------|
| 1. Chassis | 9. Pedestal | 19. Telescoping cylinder |
| 2. Transmission, either with wheels or crawler tracks | 10. Lift cylinder | 20. Upper boom |
| 3. Outrigger | 11. Lower boom 1 | 21. Telescoping boom 1 |
| 4. Outrigger cylinder | 12. Valve box | 22. Telescoping boom 2 |
| 5. Slewing ring | 13. Linkage piece 1 | 23. Jib boom |
| 6. Connection box of control system | 14. Self levelling bar 2 | 24. Self levelling bar 3 |
| 7. Lower controls | 15. Lower boom 2 | 25. Jib boom cylinder |
| 8. Self levelling bar 1 | 16. Linkage piece 2 | 26. Controls at platform |
| | 17. Upper boom cylinder | 27. Platform |
| | 18. Self levelling cylinder, "master" | 28. Self levelling cylinder, "slave" |

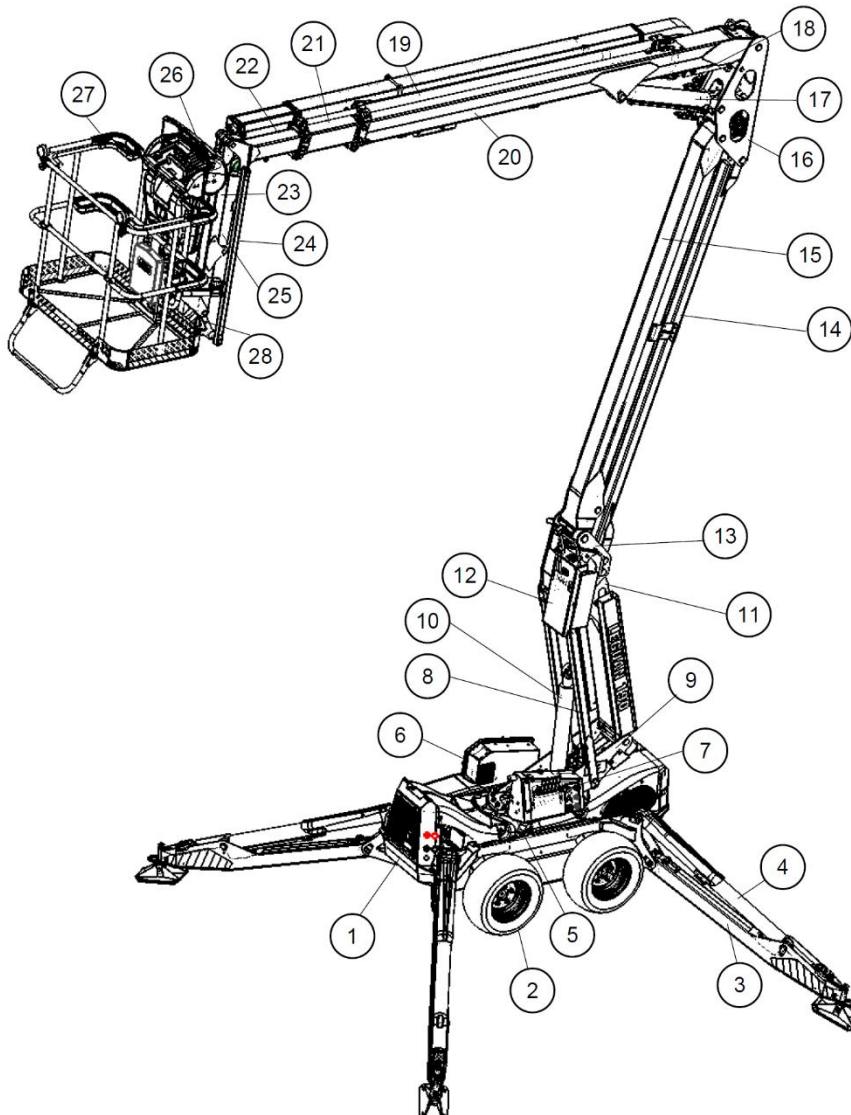

Figure 1 Main parts

2.1 Technical specifications

Working height	19,0 m
Max. platform height	17,0 m
Max. outreach @ 230 kg	8,1 m
Max. outreach @ 120 kg	9,8 m
Safe working load	230 kg
Transport length	5,07 m
Transport length without platform	4,32 m
Transport height	2,11 m
Width	1,25 m
Platform dimensions, W x L, 2 persons	1,33 x 0,75 m
Max. allowed levelling inaccuracy	1,0°
Platform rotation	± 45°
Slewing	360°
Gradeability	50 % (27°)
Gradeability sideways	35 % (20°)
Support dimensions	3,78 x 3,83 m
Max. gradient of slope for set up	22 % (13°)
Weight, depending on equipment	2660 kg
Drive system	4WD or tracks
Drive speed	max. 2,6 km/h
Speed when drive motors connected in series (option)	max. 5,2 km/h
Lowest operating temperature	-20 °C (storage -40 °C)
Starter battery / electric system	60 Ah / 12V
Sound power level at platform controls, L _{WA}	94 dB (A)
Max. outrigger force	20 kN
Max. load under wheels	0,3 N/mm ² (3 bar)
Vibration emission, a _{wmax} (uncertainty K=1,0 m/s ²)	2,6 m/s ²

2.2 Reach diagram and support dimensions

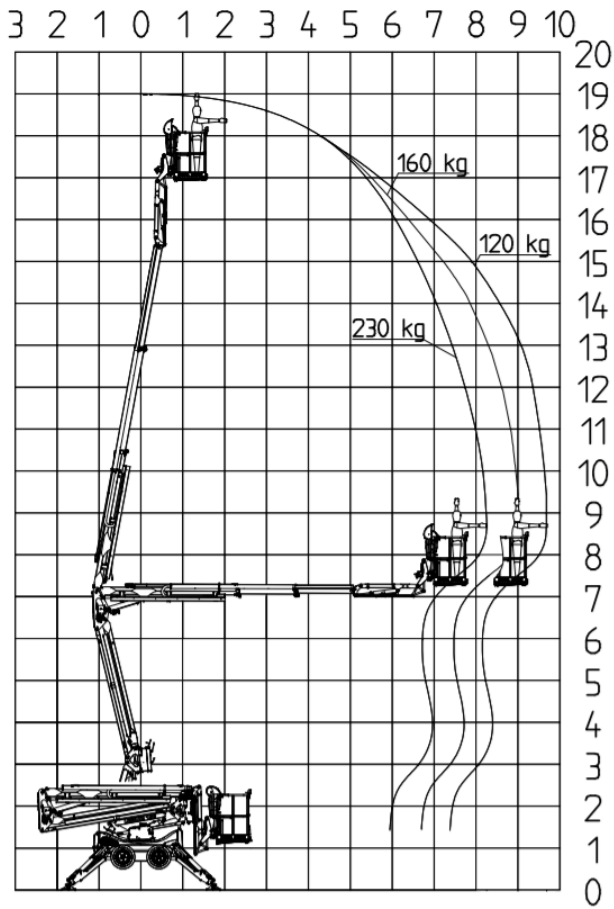

Figure 2 Reach diagram

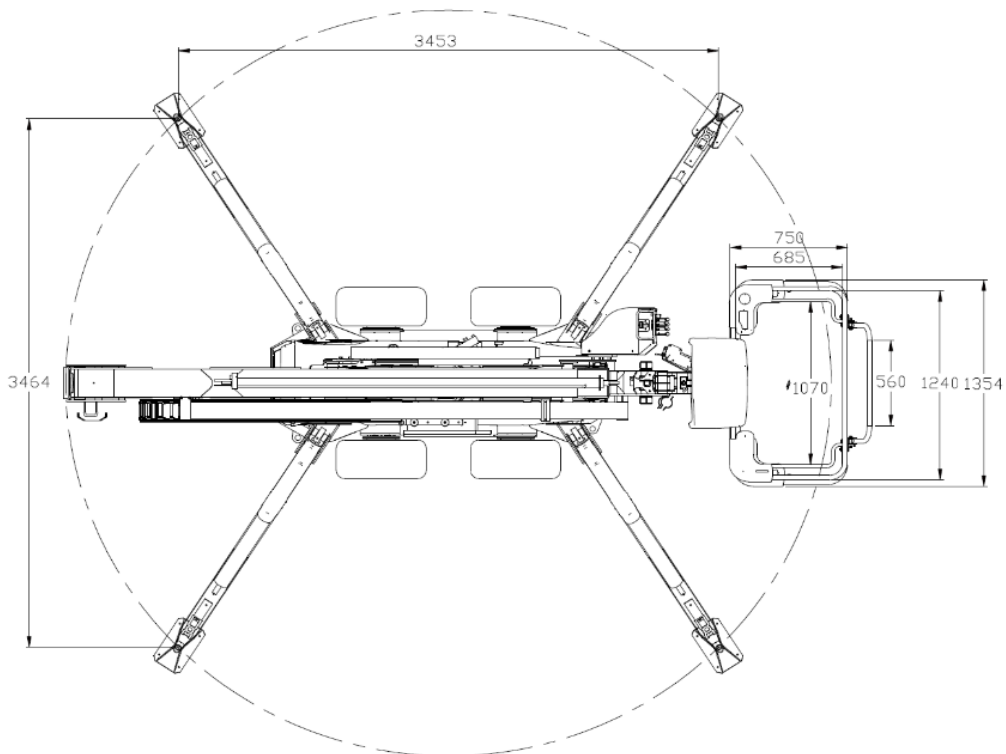

Figure 3 Support dimensions

2.3 Signs and decals

- | | |
|---|--|
| 1. Type plate and CE-marking | 10. Electric motor voltage |
| 2. Safe working load (SWL) | 11. Max. outrigger force |
| 3. Max. horizontal force and wind speed | 12. Distance from energized electric wires |
| 4. General user instructions | 13. Tie down points |
| 5. Daily inspection | 14. Tyre pressure |
| 6. Always use outriggers | 15. Leguan 190 decal |
| 7. Control symbols decal | 16. Lower controls' decal |
| 8. Emergency lowering (option) | 17. Lift points |
| 9. Residual current device | |

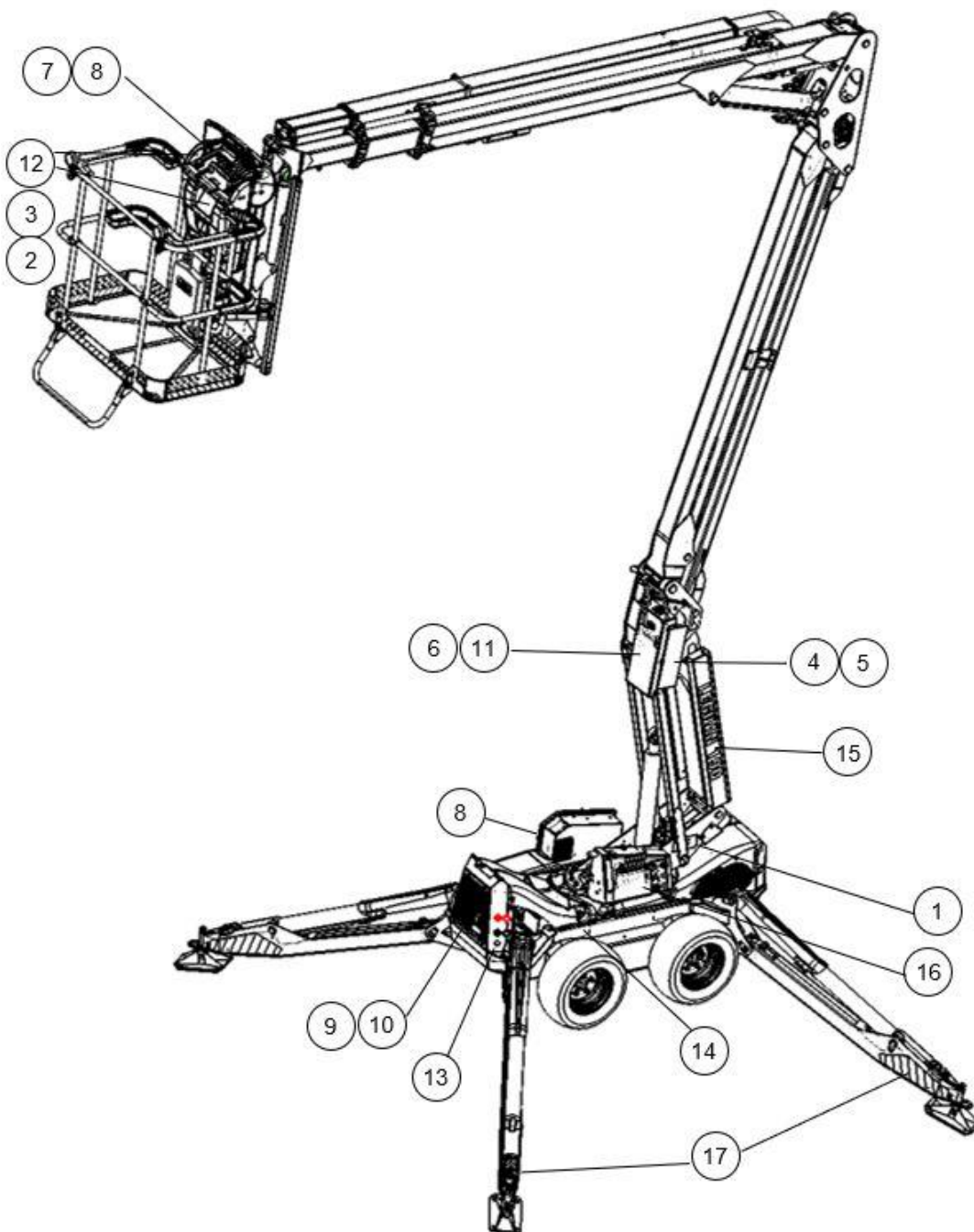

Figure 4 Signs and decals

3. SAFETY INSTRUCTIONS

The operator must know and follow all safety instructions. The operator must receive sufficient instructions in order to be able to use the lift correctly and safely. This Operators Manual must always be kept in the box on the platform.

ATTENTION!

In order to prevent unpermitted use of the access platform, take the ignition key that is located on ground level with you after ending operation.

CAUTION! DANGER!



THE ACCESS PLATFORM IS NOT VOLTAGE INSULATED. NEVER USE IT NEAR ANY VOLTAGE CARRYING PARTS OR DEVICES. DO NOT DRIVE ANY PART OF THE ACCESS PLATFORM OR PLATFORM CLOSE TO UNINSULATED CABLES OR OTHER VOLTAGE CARRYING PARTS OR DEVICES.

WHEN WORKING WITH THE ACCESS PLATFORM THE OPERATOR(S) MUST ALWAYS WEAR CERTIFIED SAFETY HARNESS WHICH IS PROPERLY CONNECTED TO THE PLATFORM.

3.1 Before starting operation

- All warnings and labels must be read carefully.
- Only persons with min. 18 years of age are allowed to use the access platform. They must have received sufficient operating instructions.
- Operator must know all the functions of this access platform as well as the Safe Working Load, loading instructions and safety instructions.
- If there is heavy traffic in the working area, it must be fenced off widely enough and marked with a fence or with a line. Road traffic regulations must be followed as well.
- Make sure that there are no bystanders in the working area.
- Do not use faulty access platform. Inform about all faults and defects and make sure that they are repaired before starting operation.
- Follow check and service instructions and intervals.
- The operator must check this access platform visually at the beginning of each work shift. This check is necessary in order to make sure that the machine is all right before making the daily inspection prior to starting operation.
- If combustion engine is used indoors, make sure that the ventilation is sufficient.

3.2 Risk of tipping over

- Safe working load (230 kg), number of persons (2) and additional load on the platform must never be exceeded.
- When wind speed is equal to or greater than 12,5 m/s - 28 mph, the use of the access platform must be discontinued immediately and the platform must be lowered down to transport position.
- Ensure that the access platform is used on dry, solid, level ground only. The ground is solid enough if it can carry min. 3 kg/cm². On softer grounds use extra support plates under the outriggers (plate dimensions 400 x 400 mm).
- Do not use a ladder, chair, stool, scaffolding or by any other means try to increase reach capability of this access platform.
- In case the platform has got stuck or jammed, or it is too close to a building or a wall to be moved, do not try to release the platform by operating the controls. All persons must leave the platform first (with the help of a rescue service of fire brigade if necessary), only after that one can try to lower the platform by using the emergency lowering.
- Do not increase the area of the platform or the load. Increasing of the area exposed to wind will weaken the stability of the access platform.
- Weight must be equally distributed on the platform. Make sure that additional weight cannot shift on the platform.
- Do not drive on gradients that are steeper than the max. values given for this access platform and for the slope.
- Never use this access platform as a crane or an elevator. This access platform is intended for lifting of the max. allowed number of persons and additional load only.
- Check and make sure that all tyres are in good condition. If the tyres are air filled, make sure that there is correct pressure in the tyres.
- In order to ensure the safe operation of this access platform the manufacturer has conducted approved tests for the **LEGUAN 190** in accordance with the standard EN 280:2013+A1:2015 static stability test in accordance with paragraph 6.1.4.2.1 and dynamic overload test in accordance with paragraph 6.1.4.3 of the EN 280:2013+A1:2015.

3.3 Risk of falling

- The operator(s) must always wear certified safety harnesses when operating this access platform. The harnesses must be connected to the fastening point at platform mounting bracket.
- Do not stretch or reach out over the handrails. Stand steadily on the platform floor.
- Keep platform floor clean.
- Always close the platform gate before starting operation.
- Do not drop or throw any material down from platform.
- It is not allowed to go to or step out from the platform when the booms are lifted.

3.4 Risk of collision

- Adjust the drive speed so that it is safe in regards to the ground conditions.
- The operator must follow all regulations concerning the use of safety equipment on the work site.
- Make sure that there are no overhead obstacles on the work site that could prohibit lifting of the platform, or objects that might cause a collision.
- Do not operate this access platform in the working area of another overhead lifting device or similar equipment that is moving, unless this lifting device is secured so that there is no risk of collision.
- Beware of crushing hazard when holding the handrail of the platform in an eventual collision situation.
- When operating the lift, beware of eventual limited visibility and trapping hazard.

3.5 Risk of electric shock

- This access platform is not voltage insulated nor protected against contact with voltage carrying parts, or when approaching them.
- Do not touch the machine if it comes in contact with voltage carrying electric line.
- Persons on the platform or at ground level must not touch or operate the platform before power has been cut off from the electric line.
- During welding repairs, it is not allowed to use any part of this access platform as earth conductor.
- Do not use this access platform during thunderstorm or high winds.
- Leave clearance to electric lines taking into account movements of platform, movements of electric line, and high winds and gusts.

The minimum safety clearances to voltage carrying electric lines are shown in the following table. These clearances must be respected.

VOLTAGE	MIN DISTANCE
0 - 1000 V	2 m
1 - 45 kV	3 m
110 kV	5 m
220 kV	5 m
400 kV	5 m

3.6 Risk of explosion/fire

- It is not allowed to start the combustion engine / electric motor in a place where one can smell LPG, petrol, solvent or other flammable substance.
- Do not fill with fuel when the engine is running.
- Charge the battery only in places with sufficient ventilation, where there is no open fire or no works which could cause spark emissions (like welding).
- In case of fire it is recommended to use carbon dioxide fire extinguisher. Dry powder extinguisher can also be used but in this case the machine must be cleaned and inspected thoroughly because the powder is corrosive.

3.7 Daily inspection before starting operation

- Ground
- Supports
- Horizontal levelling
- Emergency stop button
- Emergency lowering
- Controls
- Operating area
- Platform
- Oil leakages
- Working area

ATTENTION! If you note faults or missing equipment on this access platform, do not put it into operation before the faults have been corrected. Never set the access platform up in a place where the ground may be too soft. Beware of soft grounds and potholes in particular.

3.8 Use of emergency stop switches

- To use an **emergency stop** or **kill switch** just press down the switch's red cap (figure 5 (25) and figure 6 (4)).
- Kill switches are used in emergency situations when normal shutting down procedures are not possible. For example in accidents and other dangerous situations involving the lift or its user.
- Kill switches shut down the engine but outrigger monitoring stays switched on.
- Kill switches in upper and lower control panels can be used at any time.
- Kill switches can be returned to neutral position by twisting its red cap clockwise.
- The emergency stop button in remote control unit will only operate when the remote control use is selected

3.9 Safety instructions for drive control

1. Do not exceed maximum inclination for drive.
2. Make sure the driving surface is solid.
3. Fasten tools and other materials to prevent them falling.
4. Wear safety harnesses and keep them fastened whenever operating the machine.

3.10 Defining the gradient of the slope

Measure the slope with a digital clinometer, or do as follows:

Take a water level, a straight piece of wood at least 1 m long, and a pocket tape measure.

Place the wood on the gradient. Put the water level on the lower edge of the stick and lift the stick until it is in horizontal position. Keep the stick level and measure the distance from the lower end of the stick to the ground. Divide the distance (height) by the length of the wood stick (distance) and multiply the result by 100.

Example:
 Wood length = 2 m
 Height = 0,5 m
 $(0,5 / 2) * 100 = 25 \%$ slope

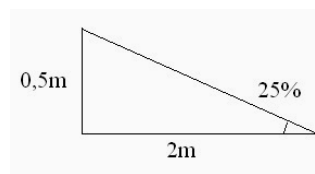

ATTENTION! When crossing slopes always drive up or down the slope, not sideways. If you have to drive sideways on a slope, lower the downhill side outriggers so that they are close to the ground. This prevents the machine from tipping over.

4. CONTROLS AND SWITCHES

4.1 Controls in platform

The controls and indicators on the control panel at platform may be slightly different in different models. Indicators and switches that are marked as options are not mounted on all models.



Figure 5: Upper control panel's levers, switches and buttons

- | | |
|--|---|
| <ol style="list-style-type: none"> 1. Diesel- and electric motor start- and stop-button 2. Glow light 3. Speed selection switch 4. Automatic leveling switches (see 5.4.1) 5. Automatic leveling indication light (blinks) / boom use allowed (continuously ON) 6. Outrigger control switches (see 5.4.2) 7. Platform overload indicator light (see 4.1.1) 8. Outreach control indicator light (see 4.1.2) 9. Fault light (see 4.1.3) 10. Boom center position indicator (slewing) (see 4.1.5) 11. Boom transport support indicator light (see 4.1.6) 12. Low fuel level indicator | <ol style="list-style-type: none"> 13. Inclination sensor indicator light (see 4.1.4) 14. 1st Boom control lever 15. 2nd boom control lever 16. Boom slewing control lever 17. Telescope boom control lever 18. Jib boom control lever 19. Platform tilting control lever 20. Outrigger monitoring override button (see 6.4) 21. Platform rotation 22. Horn / outrigger beacons' switch (option) 23. Control panel / platform work light switch (option) 24. Emergency lowering selector and button (option) 25. Emergency stop switch (see 3.8) |
|--|---|

4.1.1 Platform overload indicator light

This access platform is equipped with automatic platform overload system which prevents all boom movements in case the 230 kg safe working load is exceeded. Should this happen, there is an audible warning signal and an indicator light up at the control panel (Figure 5 (7)). The booms can be operated again after the overload has been removed from the platform.



NEVER OVERLOAD THE PLATFORM!

4.1.2 Dynamic outreach control signal light

This access platform is equipped with dynamic outreach control. Outreach depends on the actual load on the platform.

- Red dynamic outreach control signal light (Figure 5 (7)) will blink and an audible sound alarm can be heard when the telescope boom is about to reach the current maximum outreach.
- The frequency of the blinking light as well as the audible sound will increase as the telescopic boom closes the maximum outreach.
- When the maximum outreach is achieved red dynamic outreach control signal light will stay continuously on and:
 - Telescope boom movement out is prevented.
 - 2nd boom movement down is prevented.
- Continuous audible sound will signal that the maximum outreach is achieved.



2nd boom cannot be lowered before moving the telescope boom slightly in.

4.1.3 Fault light

The fault light will signal errors and faults on the equipment. Possible faults are divided into two categories based on their severity.

When an **ERROR** occurs, the red fault light will **BLINK**.

- Equipment can be used with extreme caution.
- Some features are prevented.
- If the red fault light blinks, return booms onto their transport positions, perform daily inspection (0) and remove possible cause of the error.
- If the problem persists, contact your Leguan dealer.



When a **FAULT** occurs, the red fault light will stay **ON continuously**.

- Ensure neither emergency stop button is pushed down.
- If the emergency buttons are not active, one of the safety components has failed and prevented the use of the equipment.
- Return booms on their transport supports, stop working with the equipment and contact your local Leguan dealer.

Possible errors and faults can be diagnosed with a separate service display (option).

4.1.4 Inclination sensor indicator light

This access platform is equipped with inclination sensor which alerts when the inclination of the chassis exceeds the given limits.

If the limits are exceeded while driving an orange indicator light will blink and give an audible alert can be heard. Drive the machine to more even surface.

While using booms the inclination sensor alert will have two stages:

If the **ALARM** limit is exceeded:

- Orange indicator light will blink and give an audible alert can be heard.
- Return all booms CAREFULLY on to their transport support
- Check that the ground is solid enough
- Re-level

If the **ALERT** limit is exceeded:

- Orange indicator light will stay on continuously and give an audible alert can be heard.
 - Telescope boom movement out is prevented.
 - 2nd boom movement down is prevented.
- Return all booms CAREFULLY on to their transport support
- Check that the ground is solid enough
- Re-level



Do not reach, slew or lift the booms when the inclination alert light is on! RISK OF TIPPING OVER!

4.1.5 Boom center position indicator (slewing)

The slew ring of the access platform is equipped with inductive sensor which lights the green boom center position indicator light whenever the 1st boom is above the transport support. Indicator light is only an aid and does not guarantee that booms will lower straight to transport supports.

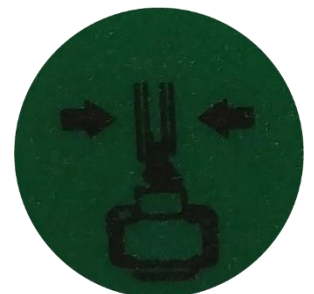

Always visually ensure that the booms are properly placed on their transport

4.1.6 Boom transport support indicator light

Boom transport support indicator light will stay continuously green when all booms are properly placed on their transport supports.



4.1.7 Low fuel level indicator

Low fuel level indicator light will be lit when there is approximately 4,5 liters of fuel left. This quantity will be enough for about 3 h of continuous working.

Fuel tank capacity is 12,5 liters.

When the low fuel indicator light is lit refuel as soon as possible (see 9.4).



4.2 Lower controls panel

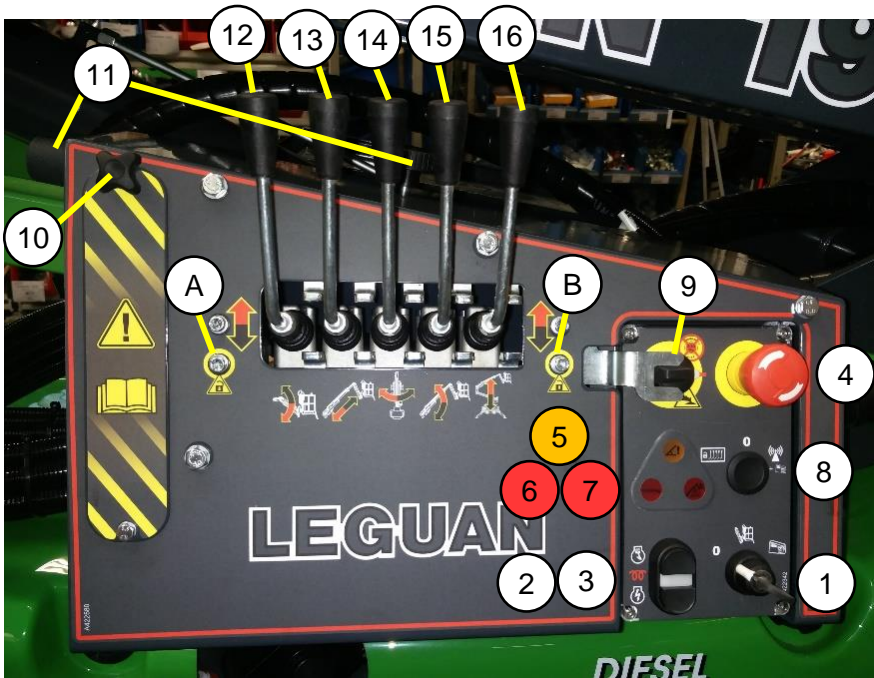

Figure 6: Lower controls panel

1. Ignition key switch / selection upper / lower controls
2. Diesel- and electric motor start- and stop-button (see 5.1)
3. Glow light (see 5.1.1)
4. Emergency stop switch (see 3.8)
5. Inclination sensor indicator light (see 4.1.4)
6. Platform overload indicator light (see 4.1.1)
7. Dynamic outreach control indicator light (see 4.1.2)
8. Dead man switch, boom use (option) / remote control selection switch (option)
9. Outrigger control / platform emergency stop and platform overload override switch (see 6.4)
10. Hand pump cover lid release
11. Hand pump handle and release
12. Jib boom control lever
13. Telescopic boom control lever
14. Boom slew control lever
15. 2nd boom control lever
16. 1st boom control lever

4.3 Wireless remote control (option)

This access platform can be equipped with wireless remote control. The remote can be used to operate outriggers and drive functions. The remote, spare battery and a battery charger are located underneath the pedestal valve box.

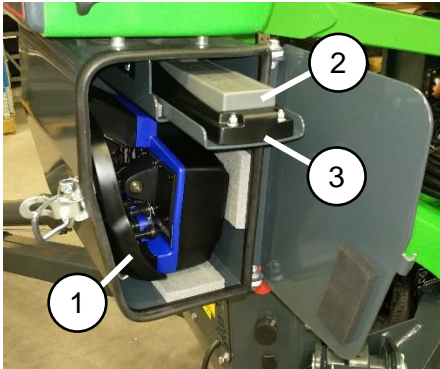

Figure 7: Remote storage

1. Remote
2. Spare battery
3. Battery charger

Protect the remote from snow and ice. If lower controls is not selected, keep the remote in the storage enclosure. The minimum temperature for the remote storage and use is -20 °C, store the remote indoors if necessary.

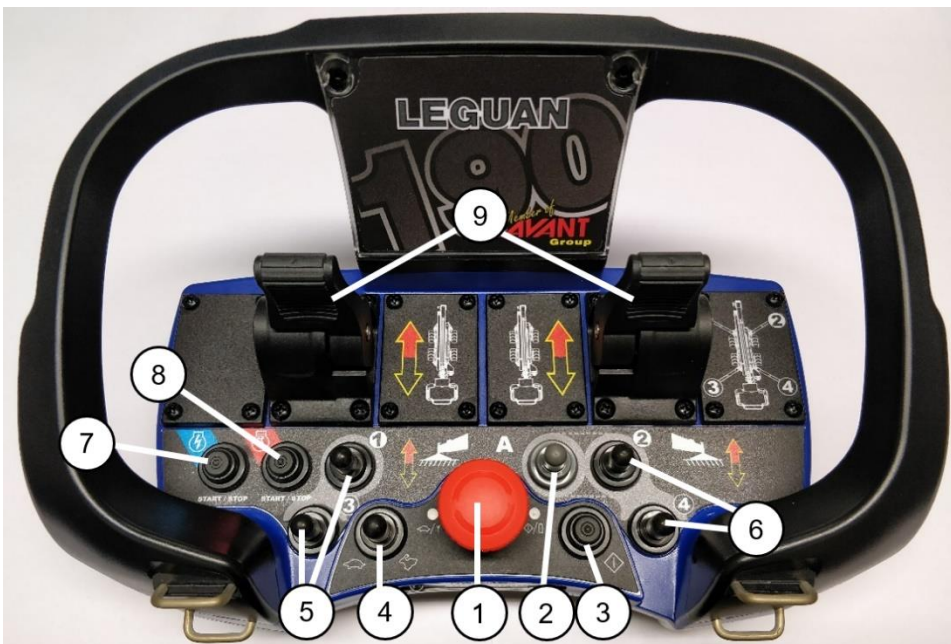

Figure 8: Wireless remote

1. Emergency stop button (The remote emergency stop will only operate when the remote control use is selected.)
2. Automatic levelling switch
3. Start button for remote
4. Drive speed selector
5. Outrigger control levers, left side
6. Outrigger control levers, right side
7. Electric motor start/stop switch
8. Combustion engine start/stop switch
9. Levers for driving

4.4 Emergency lowering button at ground level (option)



1. Hour meter
2. Electric emergency lowering selection switch and button (1st boom, 2nd boom, jib) (option)

Figure 9: Emergency lowering at ground level

4.5 230 V connection and switches (option)



1. 230 V, 50 Hz, 16 A connection
2. Residual current device
3. Battery charger. Two Led-indicators will indicate the battery level:
 Yellow = battery level low
 Yellow + green = battery level almost fully charged
 Green = battery fully charged / trickle charge



The RCD-unit switch (1) must be up in order to have any 230 V device working including the 230 V outlets at platform. One can test the function of the RCD-unit by pressing the test button in the unit. If the switch in the unit will not go down, there is either a defect on the unit or the connecting cable is not attached to mains.

5. OPERATION

An access platform is destined for lifting of persons and their equipment only. It is not allowed to use an access platform as a crane.

It is the operator's responsibility to understand and follow all operating and safety instructions.

1. Set key in the ignition key switch and select lower controls or platform controls. The access platform can only be controlled at one position only.
2. If using electric motor connect 230 V cable.
3. Unplug motor heater cable (option) if it is plugged.
4. Make sure that the booms are down in transport position. If necessary, lower the booms.

When the ignition key is turned, the access platform will perform a test sequence for the indicator lights in both control positions. This test sequence is also performed after the emergency stop button is released back up.

5.1 Starting the combustion engine / electric motor

Read carefully this Operators Manual and the Operators Manual for the engine before starting operation. Read and understand all safety instructions before starting operation.

5.1.1 Combustion engine

1. Choose preferred control position (lower controls or platform controls)
2. Press combustion engine start button, the button does not need to be held down.
3. Combustion engine red glow light will be lit and the engine will glow the required time and start automatically.
4. Press start/stop button again to stop the engine.

The access platform will automatically determine proper glow time (2-20 s) depending on the outdoor temperature. In case longer glow time is wanted, keep the combustion engine start button pushed down and release after suitable time (max. 20 s). The combustion engine will start automatically even if the start button isn't released after 20 seconds.

The access platform is equipped with auto glow function which activates when the user enters the platform. The red indication light for glow will blink when the auto glow is active. The combustion engine start button may be pushed and the red glow light will stay on and the engine will start after the required glowing is done.

In case the engine will not start on the first try, push the start button again.

Note! Do not use the emergency stop to stop the engine. Stop the engine with engine start/stop button.

5.1.2 Electric motor

1. Choose preferred control position (lower controls or platform controls)
2. Press electric motor start button, the button does not need to be held down.
3. Press start/stop button again to stop the motor.

5.2 Speed selection switch

This access platform is equipped with three speed ranges. The speed selection switch will define the maximum speed for either boom or drive.

5.3 Drive control

This access platform is equipped with hydrostatic transmission. The drive is controlled with two levers. Pushing the left-hand side lever forward will spin the left-hand side wheels or tracks forward and pulling the lever will drive the left side backwards. Right-hand side will work accordingly on the right-hand side lever.

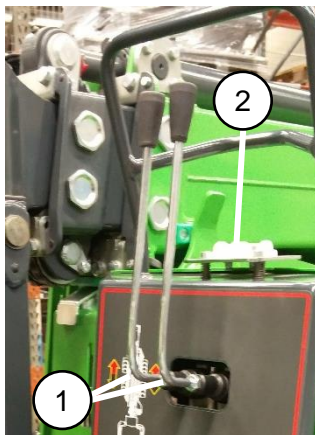

1. Drive levers
2. Water level

Figure 10: Drive control levers

To operate drive function:

1. Ensure all booms are on their transport supports, all four outriggers are lifted from the ground and the wheels/tracks are firmly against ground.
 - Make sure boom transport support indicator light is lit (see 4.1.6).
 - Make sure that the green automatic leveling light (Figure 5 (5)) **is not continuously on or blink.**
2. Start the desired engine.
3. Choose preferred driving speed (see 5.2). Changing the drive speed while the access platform is moving is forbidden!
4. Move drive control levers carefully from the center position.

The access platform can only be driven when all booms are on their transport positions!

NOTE! Learn how to drive with the machine at a low speed. Operate the drive control levers with ease in order to avoid abrupt and jerky movements. When driving pay special attention to stability and the dimensions, especially length, of the machine.

NOTE! TOWING THE ACCESS PLATFORM IS FORBIDDEN, RISK OF DAMAGE!

5.3.1 Using the crawler track chassis

An access platform with skid steer chassis, equipped with crawler track chassis, offer many advantages compared with a machine on wheels. However, certain things regarding working and working environment must be taken into account with an access platform on tracks. In order to achieve the maximum life for the rubber tracks and crawler track chassis follow the instructions below.

The lifespan of the track system of an access platform on rubber tracks is heavily dependent on the working environment and the way of working. If the access platform is being used in terrains with stones or gravel, on demolition sites where there is concrete, or in an environment with scrap metal, the lifespan of the track system can be significantly reduced.

In order to extend the lifespan of the track system avoid driving on the following terrains or work sites:

- **Environments with crushed stone, iron bars, scrap metal or similar recycling material.** Rubber tracks are not designed for this kind of environments.
- **Daily/continuous driving on asphalt or concrete.** Continuous operation on these surfaces will shorten the lifespan of rubber tracks.
- **Work sites with sharp objects, like broken stones or concrete waste.** This kind of sharp objects can cut or damage the rubber tracks permanently. Conditions which can damage tyres can also damage rubber tracks. Damaged tracks can normally not be repaired, they must be replaced. Warranty doesn't cover tracks that get damaged in this kind of conditions.
- **Work sites with corrosive substances (fuels, oil, salt or fertilizers).** Corrosive substances can oxidize the metal parts in rubber tracks. If such substances come in contact with the surface of the rubber track, the tracks must be flushed with water immediately after ending operation.

Damages on the tracks, track rollers or crawler track chassis, caused by operation in such environments, are not covered by warranty.

Operating instructions:

- **Change turning direction as often as possible.** Turning continuously only in one direction will cause uneven wear of the sprocket and the rubber track.
- **Check condition of the track system regularly.** Excessive wear on the rollers, idlers, sprockets and bearings can damage the tracks.
- **Avoid driving sideways on a gradient.** Always drive the slopes straight up and down, and turn on flat even surface only. Continuous operation on uneven terrains or driving sideways on a gradient causes wear in the track guides and rollers and makes tracks jump off the sprockets.
- **Avoid continuous sharp turns.** By making wider and more gentle turns you can avoid unnecessary wear of the tracks and/or tracks jumping off the sprockets.
- **Avoid driving with one track on level surface and one track on a gradient.** Always drive on an even surface. If the tracks bend continuously from the inside or from the outside during operation, the metal structure of the tracks can break.

NOTE! Always ensure that rocks, gravel, snow or other materials don't build up between the rubber track and the track wheels. Risk of damage to the track chassis!

5.4 Operation of the outriggers

The outriggers must be deployed and the chassis of the access platform must be levelled. The chassis can be leveled by either using automatic leveling function or controlling individual outriggers manually. The maximum allowed levelling inaccuracy is 1,0°.

Make sure that the ground under every outrigger is solid enough – put extra plates on the ground if necessary.

Booms must not be operated without properly deployed outriggers!

5.4.1 Automatic leveling

Automatic leveling will deploy all outriggers against ground and level the chassis automatically.

Set-up:

1. Press the lower button of the automatic leveling switch (Figure 5 (4)). The button doesn't need to be held down.
2. The access platform will deploy all outriggers and level the chassis automatically.
3. While the leveling is in progress the green light of the automatic leveling will blink.
4. When the chassis is leveled the green light of the automatic leveling (Figure 5 (5)) will stay on continuously. **Check the leveling from the water level (Figure 10 (2))!**
5. Booms can be operated if the chassis is leveled according to the water level also.

Setting the outriggers to transport position:

1. Lower all booms on to their transport supports.
2. Green indicator light of boom transport support (see 4.1.6) must be lit.
3. Press the upper button of the automatic leveling switch (Figure 5 (4)). The button doesn't need to be held down.
4. The access platform will drive outriggers a little off from the ground which allows the user to operate drive functions.
5. If the outriggers need to be driven in their transport positions press keep the upper button of the automatic leveling switch held down and release when all outriggers reach their transport positions.

5.4.2 Outrigger manual drive

Outrigger manual drive can be used in tight or otherwise tricky environments. If the access platform needs to be driven sideways on a slope, lower the downhill side outriggers so that they are close to the ground. This prevents the machine from tipping over.

The green light of the automatic leveling will blink when all four outriggers are firmly against the ground and will stay on constantly when the chassis of the access platform is leveled. **Check the leveling from the water level (Figure 10 (2))!**

5.5 Operation of the booms

The booms can be operated when all four outriggers are properly deployed and the chassis of the access platform is leveled. The green light of the automatic leveling (Figure 5 (5)) will stay constantly ON when these conditions are met.

The overload control system (4.1.1) will prevent the use of the booms if the safe working load of 230 kg is exceeded.

NOTE! Always lift the lower booms from transport support first before operating other movements. When lowering the booms, make sure to drive them straight down to transport supports.

Thanks to the fully hydraulic controls boom movements are very smooth, exact and stepless. Operate the control levers with ease and without hesitation – learn to operate the booms precisely.

Platform self levelling system keeps the bottom of the platform level automatically. If the level position of the platform must be adjusted – for instance in case the machine has not been used for a long time and the platform has tilted – operate the control lever of platform self levelling carefully, especially when the booms are up.

5.5.1 Automatic slewing stop function

Leguan 190 has an automatic boom rotation (slewing) stop function when returning to transport position. The stop function is activated when the upper boom (2nd boom) is lowered close to transport position and the telescope boom is pulled almost completely in.

When you are slewing towards the center position, the stop function will stop the slewing for one second once you reach the center position. When the slewing is stopped, you will hear a sound alarm - a continuous beep.

The stop function works together with the boom center position indicator (4.1.5., p. 18): the boom center position indicator lights up simultaneously as the stop function is activated.

5.5.2 Dead man switch, boom use (option)

If the access platform is equipped with a dead man switch it needs to be activated before operating the boom movements.

On the platform the dead man switch is activated by pressing the foot pedal and keeping it pressed down while controlling the boom movements.

While using the lower controls the dead man switch on lower controls panel (Figure 6, (8)) must be kept turned counterclockwise.

5.6 Remote control (option)

Lower controls must be selected in order to operate the access platform remotely.

1. Select remote control with the remote control selection switch (Figure 6 (8)).
2. Lift remote control emergency stop button.
3. Start the remote (Figure 8 (3)).
4. Start the preferred motor (Figure 8 (6) or Figure 8 (7)).
5. Use drive or outrigger functions.
 - Drive with levers (Figure 8 (8)).
 - Outriggers can be controlled with either the automatic leveling switch (Figure 8 (2)) or one at a time with individual control switches for the left-hand side (Figure 8 (4)) or for the right-hand side (Figure 8 (5)).
6. To stop, turn off the motor in the corresponding switch and then the remote by pressing the emergency stop button on the remote.
7. Place the remote in the dedicated enclosure
8. Switch remote control selection switch to "0".
9. Switch ignition key switch to "0".

The remote emergency stop will only operate when the remote control is selected.

5.7 Ending the operation

After ending the operation:

1. Lower the booms down to transport position.
2. Lift the outriggers completely up to transport position.
3. Stop the combustion engine / electric motor by pressing the stop button of the motor.
4. Remove safety harnesses from the platform and take them with you (harnesses must be kept in their place and in their box/package).
5. Turn the ignition key switch to "0" and take it with you.
6. If the machine stays in a place where it can be connected to 230VAC mains current, it is recommended to leave it connected to charge the battery (e.g. overnight).

NOTE! Prevent unauthorized use of the lift by removing ignition key and main disconnect switch from the machine when it's not used!

5.8 Additional instructions for winter use

The minimum allowed operating temperature for the access platform is -20 °C.

Do the following actions during winter time:

- Check that the limit switches are free from snow, ice and dirt.
- If the ambient temperature is below +2 °C the manufacturer recommends to use a separate engine heater (option).
- Let the engine run for a few minutes before moving the machine.
- First use drive mode for a while, then use outriggers and lastly use the booms. This way the oil in the whole system heats up and warm oil flows to the cylinders.

6. EMERGENCY LOWERING AND EMERGENCY USE

If the power supply for some reason cuts off (e.g. no fuel or electricity cuts off, or connecting cable fails) the booms can be lowered using the following methods.

6.1 Hand pump

The access platform is equipped with a hand pump, which can be used to operate boom functions.



Figure 11: Hand pump

Using the hand pump:

- Stop the engine.
- Release the hand pump handle (Figure 6 (11)) and open the protective lid (Figure 6 (10)).
- Place the handle in the pump.
- Use the pump control and lower control levers (Figure 6 (12-16)) to bring the booms on their transport positions.

Hand pump must only be used in emergency situations to lower the boom. Always lower the jib boom and the 1st boom and drive telescopic boom in before lowering the 2nd boom. **Risk of tipping over!**

6.2 Electric lower controls (option)

1. If the access platform lift is equipped with an electric emergency lowering system. There are emergency lowering buttons on the platform control panel (see 4.1) and at ground level (see 4.4). By pushing the button the selected boom comes slowly down as long as the button is being pushed. Emergency lowering button can only be operated from the selected control position. If the ignition key switch is at "0" position, it is possible to use the emergency lowering from platform since in that case the button takes its' power directly from the battery. Emergency lowering valves are protected with a 10 A fuse which is located in the connection box on the side at ground level.
2. Always lower the jib boom and the 1st boom and drive telescopic boom in before lowering the 2nd boom. Before lowering the booms to transport supports always make sure that they are properly aligned and going straight down to transport supports. If necessary, the booms can be rotated at the end of the slewing ring shaft either with the hand pump or a 22 mm spanner or with a socket wrench at ground level. Before operating the slew turn the ignition key to "0".

NOTE! Always remember to remove the tool after rotating the booms. Never rotate the slewing ring by hand when the combustion engine / electric motor is running and the main current is on!

If the access platform is equipped with electric emergency lowering always check function of emergency lowering before starting operation.

6.3 Outrigger control override



For possible emergency situations this access platform is equipped with outrigger monitoring override button (Figure 5 (20) or Figure 6 (9)), which allows the user to operate booms even the outriggers are not deployed properly. This function can be used for example in a situation where the jib boom needs to be lifted a little because of rough terrain or the platform has tilted backwards while extended storage. **Override button must only be used in extreme situations!**

Outrigger monitoring override **at platform:**

1. Open the locking screw of the lid to access the button.
2. Press the white override button down and keep it pressed.
3. Start combustion or electric motor.
4. Do the required boom movements.
5. Release the white override button and stop the motor.
6. Close the lid and tighten the locking screw.

Outrigger monitoring override **at ground level:**

1. Open the screws (Figure 6 (A) ja (B)) to release the protective plate.
2. Slide the protective plate left.
3. Turn the override switch clockwise and keep it turned.
4. Start combustion or electric motor.
5. Do the required boom movements.
6. Release override switch, stop the motor.
7. Slide the protective plate right.
8. Tighten the screws A and B.

ATTENTION! If the booms are not on their transport supports an audible alarm will be given and the movements will stop after 1,5 seconds. The override switch must be released for one second and activated again to enable boom movements again for 1,5 seconds. Override switch may only be used for operating the booms close to their transport supports. **RISK OF TIPPING OVER!**

6.4 Platform load control and platform emergency stop button override



For possible emergency situations this access platform is equipped with load control and platform emergency stop override switch (Figure 6 (9)), which allows the user to override platform emergency stop button and operate booms with overload. Override is only possible when the lower controls is selected.

This switch must only be used in **extreme emergency** situations e.g. operator has lost consciousness in the platform, the emergency stop button has been activated and the user must be lowered for his/her safety.

When using safety functions override switch it is possible to operate the machine outside its stable working zone, which creates a falling hazard! The manufacturer is not responsible for the lifts falling when safety functions override switch has been used!

Platform load control and platform stop button override:

1. Open the screws (Figure 6 (A) ja (B)) to release the protective plate.
2. Slide the protective plate left.
3. Choose lower controls.
4. Turn override switch counterclockwise and keep it turned.
5. Start combustion or electric motor.
6. Lower the boom **with extreme caution**.
7. Release override switch, stop the motor.
8. Slide the protective plate right.
9. Tighten the screws A and B.

6.5 Boom transport position monitoring override

For possible emergency situations this access platform is equipped with boom transport position override button (*Figure 5 (20)*). This feature allows the user to operate the outriggers and drive the access platform to a safe area in an emergency. The feature is meant to be used in a fault situation when one of the booms is not in transport position or if one of the transport position sensors and/or the boom angle/outreach sensor is faulty and prevents the operation of outriggers and drive. **Use with extreme caution and only in an emergency!**

The override button is locked with a hexagon screw. Unlock the lid to operate the button.

Boom transport position monitoring override at platform:

1. Turn on the main switch (*figure 6 (1)*) to lower control position
2. Within 1-10 seconds after the machine has turned on, push down the override button (*figure 5 (20)*) in the platform control panel (pushing down the button switches the controls to the upper control panel from the lower control panel)
3. Keep the override button pushed down the whole time you wish to use the function
4. Start the engine or electric motor from the platform control panel (*figure 5 (1)*) while holding down the override button
5. While pushing down the button, use the outrigger switches to drive the outriggers up towards transport position or drive levers (*figure 10 (1)*) to move the access platform to a safe area
6. If you release the override button too early, you have 10 seconds to press it again to keep the override function activated
7. After the operation is finished, lock the override button's lid with the provided hexagon screw to prevent unnecessary use.

When using safety functions override button, it is possible to operate the machine outside its stable working zone, which creates a falling hazard! The manufacturer is not responsible for the lifts falling when safety functions override button has been used!

7. TRANSPORTATION

Before transportation lower the booms down to transport position and lift the outriggers completely up to transport position.

NOTE! Transporting of this access platform is allowed in its transport position only. No persons or materials are allowed to be transported on the platform.

All outriggers are equipped with lifting points (Figure 12) from which the access platform can be lifted if necessary. When lifting, it is advisable to use a lifting beam where the ropes are mounted, in order to prevent the outriggers from being damaged.

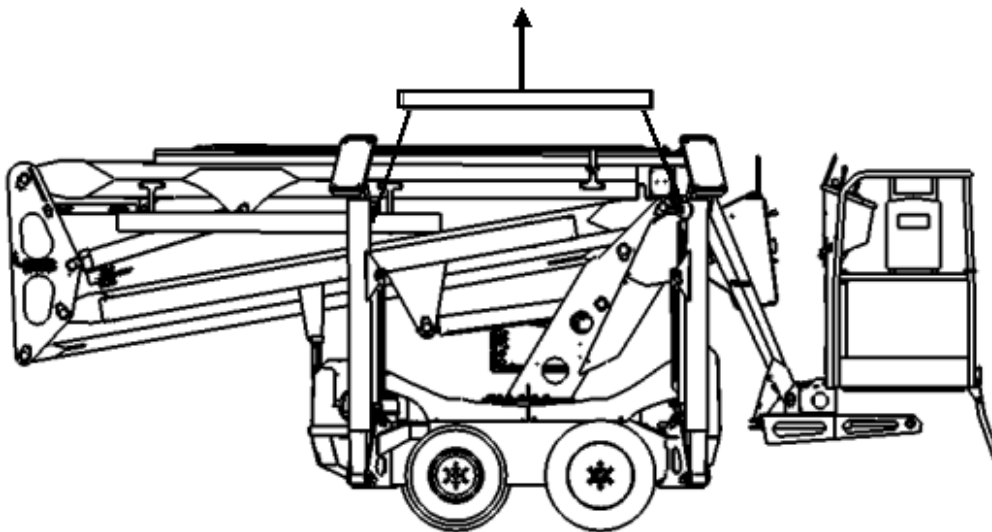

Figure 12: Lifting the access platform

There is an automatic hydraulic brake in the rear axle which engages automatically when the combustion engine/ electric motor is not running. **The access platform must not be parked in steep slopes.**

If the machine is transported on a trailer or on a lorry or a similar vehicle, it must be tied down properly. There are four tie-down points marked on the corners of the chassis which make it easy to tie down the machine. Always tie the machine down diagonally from every corner (Figure 13).

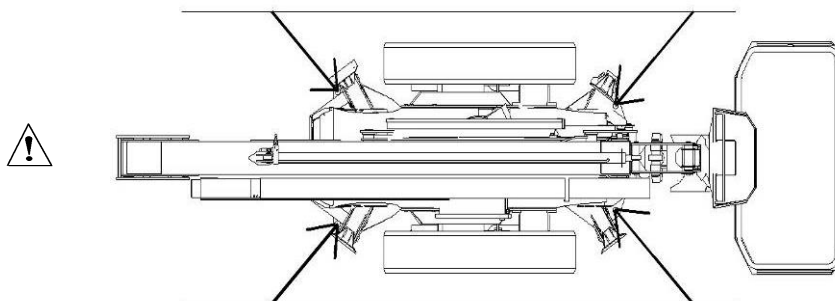

Figure 13: Tie-down points

ATTENTION! It is not allowed to tie down the machine so that the ropes go over the booms. Only marked tie-down points can be used!

8. SERVICE, MAINTENANCE AND INSPECTION REGULATIONS

This access platform must be inspected once a year. The inspection can only be done by a qualified person. Persons who conduct the periodical services shall familiarize themselves with the operation and technical features of this access platform before doing any service operations. All service and maintenance operations must be made in accordance with the instructions in this manual.

8.1 General instructions

- It is not allowed to make any changes on the construction of the machine without written permission from the manufacturer.
- All defects that may have an effect on the safe use of this access platform must be repaired before starting operation.
- Only professional persons are allowed to open the covers and handle the electric etc. components. Risk of serious injury!
- Make sure that services are made in accordance with this Operators Manual and with the Service Manual of the engine manufacturer.
- Stop the engine before starting any service or inspection operation, DISCONNECT ALSO THE 230 V MAINS CURRENT.
- Do not smoke during service and inspection operations.
- Keep the machine and especially the platform clean.
- Make sure that the operating instructions are complete, readable and in their place in the box at the platform.
- Make sure that all stickers are in their place and readable.
- Make sure that the access platform has been serviced according to the manual.
- Make sure that all inspections have been made according to local regulations.

ATTENTION! All spare parts – especially electric components and sensors – must be original Leguan parts.

9. SERVICE INSTRUCTIONS

9.1 Service and checks, maintenance schedule

Regarding the service of the engine see also engine manufacturer's Operators Manual = EM

CH = Check CL = Clean R = Replace A = Adjust F = First service at 50 h

Operation	day	month	100 h	200 h / 12 month	400 h / 24 month	1000 h
Engine oil, EM	FR	CH		R		
Engine oil filter	FR			R		
Air filter, EM		CH/CL		R		
Glow plug, EM						CH
Valve clearance, EM						A
Fuel filter					R	
Fuel tank			CH			CL
Fastening of platform	FCH	CH				
Hydraulic oil						R
Hydraulic oil level			CH			
Hydraulic oil suction filter						CL
Hydraulic oil filters	FR			R		
Battery		CH				
Coolant	FCH	CH			R	
Locking of bearings and pivot pins	FCH	CH				
Electric wires				CH		
Hydraulic fittings and hoses	FCH	CH				
Cylinders, load holding- and check valves	FCH	CH				
Function of emergency lowering	FCH	CH				
Function of emergency stop circuit	FCH	CH				
Function of set up system	FCH	CH				
Pressure adjustments	FCH			CH		
Function of control valves	FCH	CH				
Mounting of booms on the chassis			CH			
Condition of steel structures			CH			
Movement speeds of the booms	FCH	CH		A		
Greasing 9.3		R				
Function of load control system and outrigger limit switches (9.8 & 9.12)	FCH		CH	A		
Level position of water level	FCH	CH				
Safety valves (9.15)				CH	CH	

Hydraulic oil:
Hydraulic system oil volume:
Fuel tank capacity:

Mobil UNIVIS HVI 26 (Arctic oil)
Oil tank 35 l, complete system 55 l
12,5 liters (Diesel)

Engine oil:	See engine manufacturer's manual.
Grease:	Lithium NLGI 2 grease (not MoS2), slewing ring with grease containing EP (extreme pressure) (e.g. Mobilux EP 2 Moly)
Pressure settings of hydraulic system:	Main pressure 200 bar (2900 PSI)
	Lower operating pressure 110 bar (1595 PSI)
	Brake opening pressure 25 bar (363 PSI)
	Leguan TeHo trailer 6,0 bar (87 PSI)
Tyre pressure:	23*10.50-12 grass profile 3,0 bar (43 PSI)
	23*10.50-12 TR profile 3,0 bar (43 PSI)
	Leguan TeHo trailer 6,0 bar (87 PSI)

Do not exceed maximum inflation pressures marked on the tyres.

Backlash of the wear pads on the telescopic boom must be checked every year and the wear pads must be replaced every 5 years.

The pulley chains and/or cables of the telescope booms, their pulley wheels and fasteners must be replaced during the access platform's 10-year service.

Tightening torque of the M16 fastening bolts of the slewing ring is 210 Nm – torque must be checked once a year and bolts must be changed every 5 years. If a bolt has loosened, it must be replaced with a new bolt.

Above mentioned service intervals are recommendations. If the operating conditions are very hard and/or the machine is in heavy duty use the service and change intervals must be shortened.

9.1.1 Crawler track sprocket nuts

It is important to check tightening of nuts on the rear sprocket (bigger track wheel) about one week after putting the access platform into operation. When driving with a new machine the parts in the track system adapt to each other and "find their place" so to say. Because of this it is possible that the nuts loosen during operation. Loose nuts can cause serious damage to the crawler track chassis.

- First tighten the nuts to 200 ± 25 Nm diagonally opposite.
- Finally tighten the nuts to **250 ± 25 Nm** diagonally opposite.
- Tightness of nuts should be checked yearly.

9.2 Fuses

The fuses of this access platform are located on the left side of the machine inside the electric box.

1. Fuses, voltage when ignition key switch is ON (lower or platform controls selected)
2. Fuses, constant voltage from battery
3. Spare fuses

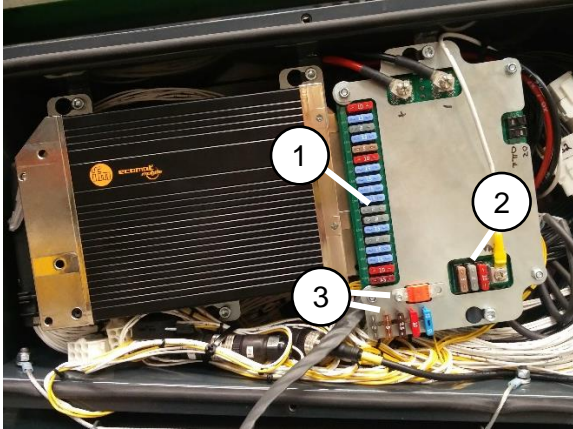

Figure 14: Fuses

Do not exceed original fuse size!

9.3 Greasing

Greasing of the machine is of utmost importance to prevent wear in joints. Most of the joints are service free - however the slewing ring must be greased in accordance with the maintenance schedule, using grease that contains EP (extreme pressure) additive. Outrigger bearings and articulation bearings in all hydraulic cylinders must be greased in accordance with the maintenance schedule.

9.3.1 Greasing of the slew ring

The slewing ring of the access platform must be greased monthly, according to the maintenance schedule. It is important to notice that the slewing ring has five (5) separate greasing points (Figure 15) which all must be greased individually. The grease nipples on the outside of the slewing ring are connected to the gear and its bearings. Two (2) grease nipples on the inside of the slewing ring are connected to the ring's ball bearings. Easiest way to apply grease on these two grease nipples is through the service hatch on the bottom of the chassis.

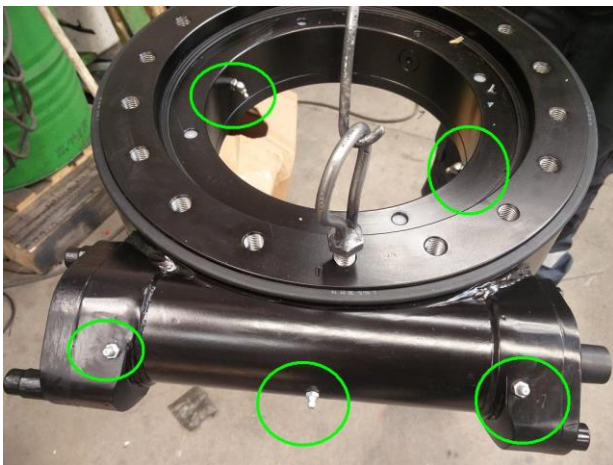

Figure 15: Slewing ring greasing

9.3.2 Greasing the telescopic boom chain pulley and inspection of the chain

A pair of leaf chains is used for telescopic boom movement. There are 3 pulleys which require greasing. Pulleys are greased monthly.



Figure 16: Telescopic chain pulley grease nipple



Figure 17: Leaf chain pulley greasing points in the front side of the 2nd boom.

Grease nipples are located on both ends of the telescopic boom. One grease nipple is located under the telescopic boom in the platform end of the boom (Figure 16). Two more nipples are located under a protective cover in the front side of the 2nd boom.

9.3.3 Greasing of Telescoping Booms

Glide surfaces of the telescoping booms (bottom surface, picture 18) should be greased with water resistant grease (e.g. Mobil XHP 222) during monthly greasing. The grease should be applied on the bottom surface of both middle boom and extension, on a surface area of approximately 30 mm wide measured from each side edge and for the whole visible length of the booms when the telescope is fully extended (picture 19). Apply only a thin layer (< 1 mm) of grease on the surface by using a brush for example.

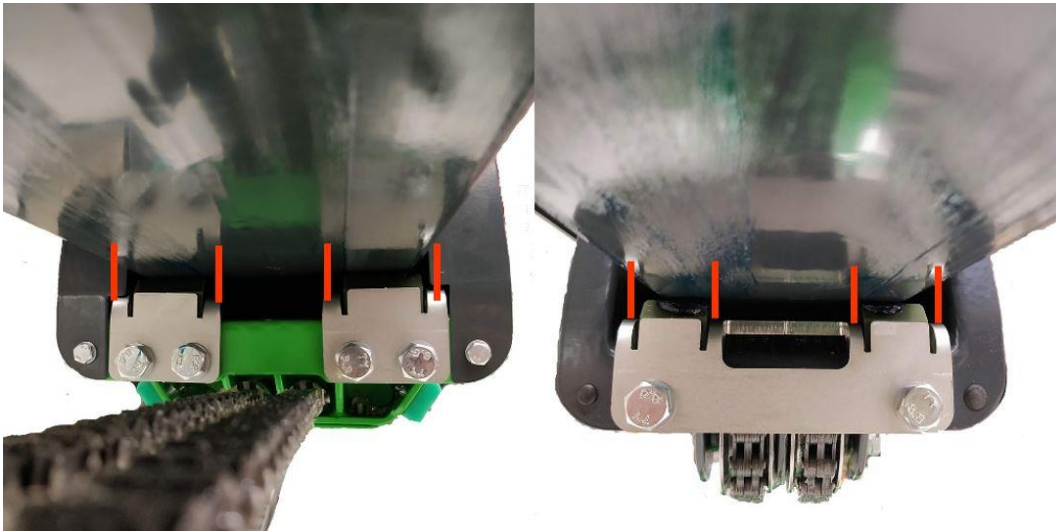

Figure 18 Width of the greased surface on Middle Boom and Extension highlighted with red lines

9.3.4 Greasing of the Position Sensor Pins on the Outriggers

The position sensor pins on the outriggers should be cleaned and greased with water resistant (e.g. Mobil XHP 222) during the yearly maintenance of the access platform. The pin is removed from the outrigger by opening the locking screw on the end of the outrigger (figure 19, A). The pin is moved by a spring which is to be removed before the greasing. Apply only a thin layer (< 1 mm) of grease on the surface of the pin by using a brush for example. After greasing install the spring back on the pin and place the pin back on the outrigger and lock carefully it with its screw.

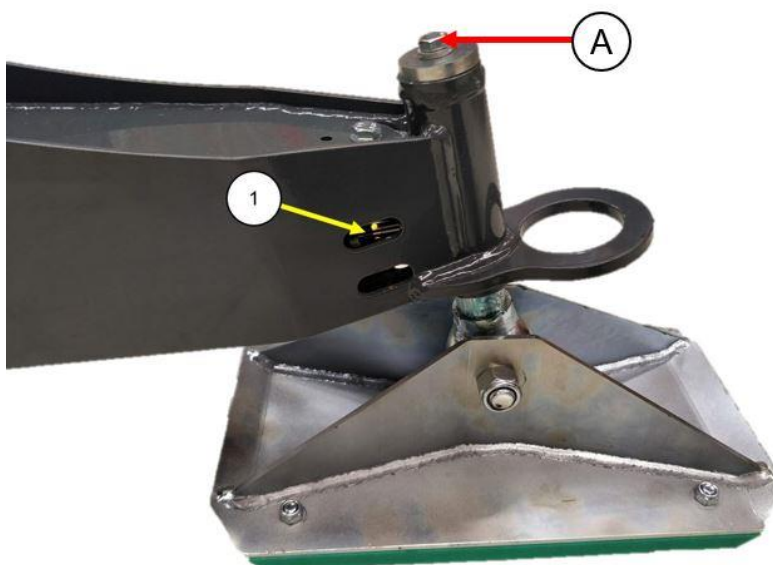

Figure 19 Outrigger position sensor pin locking screw (A) and outrigger limit switch location (1)

9.3.5 Greasing diagram

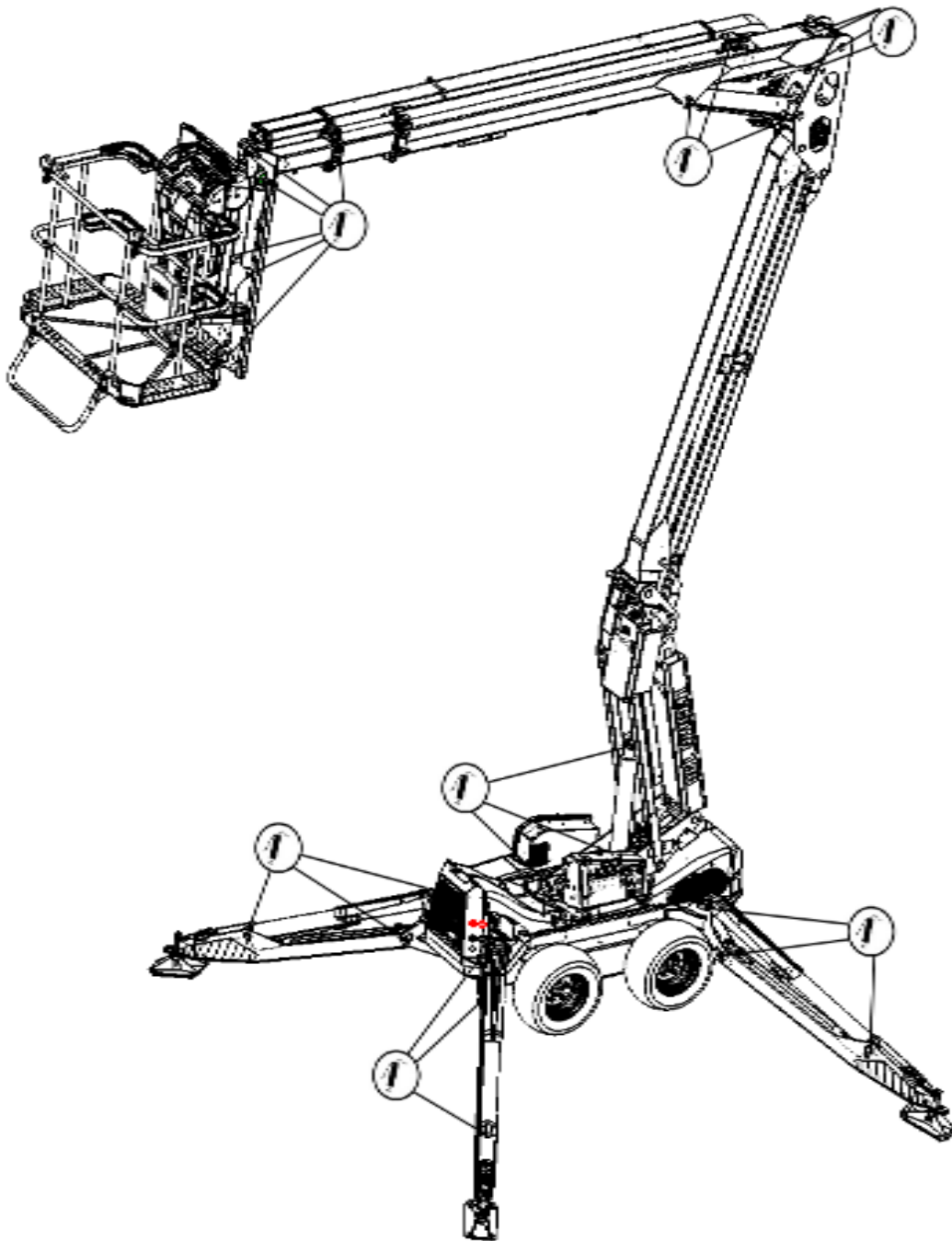

Figure 20: Greasing diagram

9.4 Handling of fuel and refueling

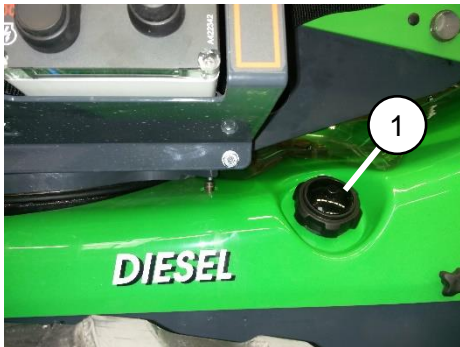

Figure 21: Fuel tank cap

Check fuel level and refuel if necessary (fuel tank cap, 1). For Kubota engine use **DIESEL** fuel only. See engine manual. Use of other fuels is not allowed.

Make sure not to let the fuel tank get empty. Should this happen, refuel and restart several times in 20 s intervals. The engine is fitted with automatic fuel bleeding.

9.5 Hydraulic oil and hydraulic oil filter replacement

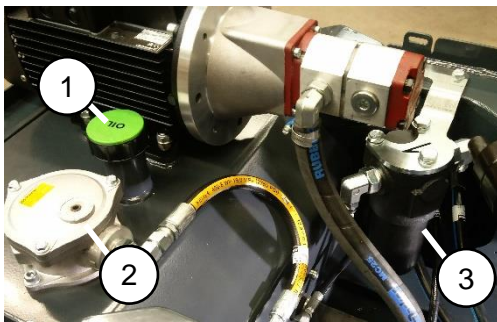

Figure 22: Hydraulic oil filters

Hydraulic return oil (2) filter is located on top of the hydraulic oil tank at the rear of the chassis. Replace the filter by removing the filter cap and replacing the filter cartridge. When replacing the hydraulic oil, the oil can be removed with a suction pump from the opening of breather cap (1), or by opening the drain plug. In both cases it is important to clean the magnetic drain plug.

Hydraulic pressure filter cartridge (3) must be changed always when return filter is changed. Take off the filter bracket, lift up the filter, open and replace the filter cartridge. Pressure filter cartridge is mounted inside the filter case with the cartridge's opening facing up and the case.

After this mount the case back to the bracket. Make sure there are no leaks when the engine is running.



Figure 23: Return line filter cartridge



Figure 24: Pressure line filter cartridge

9.6 Hydraulic oil level

Hydraulic oil level can be checked with the dipstick in the filler cap (Figure 20 (1)). Oil level should be at the upper mark in the dipstick when the lift is in transport position (booms down on transport supports and outriggers completely up).

9.7 Battery check

The original battery is maintenance-free. In order to secure the starting and safe operation the battery must be checked regularly. Inspect and clean battery terminals regularly. Check also condition and fastening of battery cables and terminal insulators. Make sure that battery cables cannot chafe against any sharp edges. Check also condition and fastening of battery disconnect switch and cables.

9.8 Check of set-up control system

Check set-up control always before operating the access platform.

When all four outriggers are firmly against ground the green automatic leveling signal light will blink (Figure 5 (5)). Drive outriggers **manually** against ground:

- If the green automatic leveling signal light will blink before all four outriggers touch the ground the outrigger control system there is a malfunction or a fault in the system and the operation must be stopped immediately (excluding the situation where automatic leveling has been activated).
- The cause of the malfunction can be found out on the splitter box (Figure 23) in the rear of the chassis. In the box connectors 1-4 are equivalent to the numbering of the outriggers
- Connectors' equivalent limit switches are: 1 = S21, 2 = S22, 3 = S23, 4 = S24.
- When the outriggers are off the ground or in transport position indicator light A should be lit next to connectors 1-4.
- Similarly when outriggers are set to the ground indicator light B should be lit. If there is a malfunction the wrong light will be lit or possibly none of the lights light up. Check the function of the splitter box during monthly inspection.

ATTENTION! If the set up control system doesn't work correctly, it is not allowed to use this access platform, and the failure/defect must be repaired before starting operation.

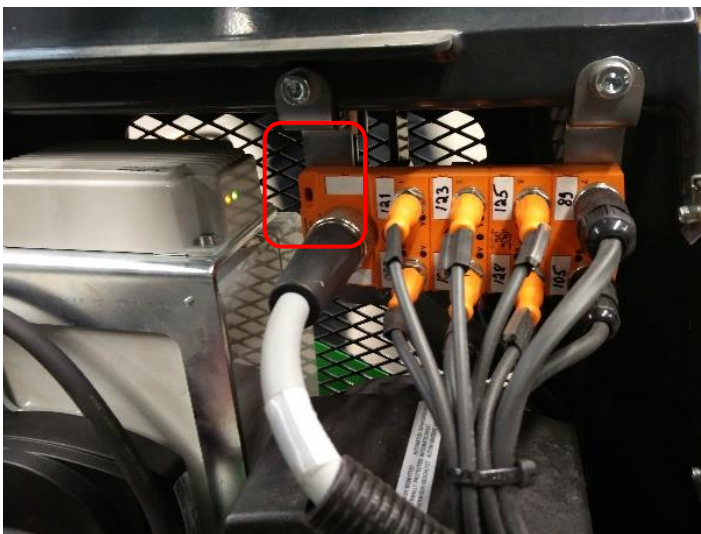

Figure 25: Splitter Box, outrigger connectors marked inside red square

9.11 Pedestal valve housing

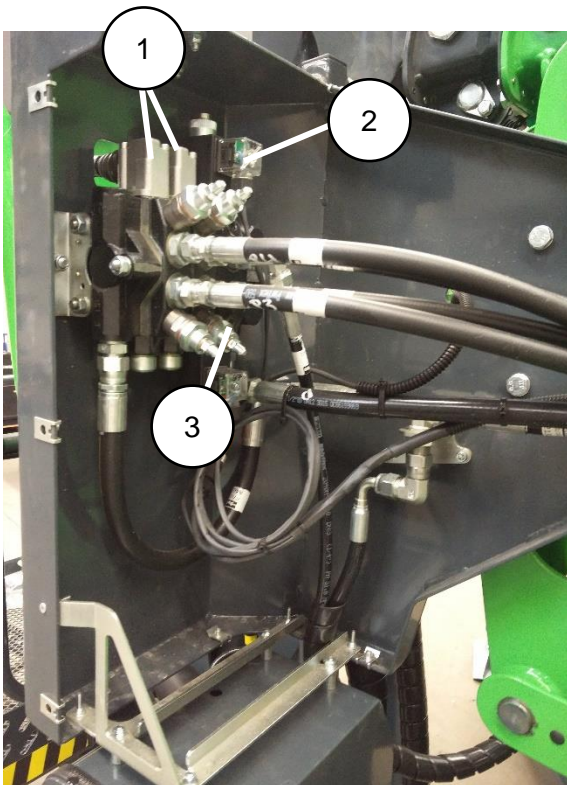

Figure 27: Pedestal valve housing

Components inside the pedestal valve box:

1. Drive valves
2. Platform boom control valve solenoid K98
3. Lower controls boom solenoid K99

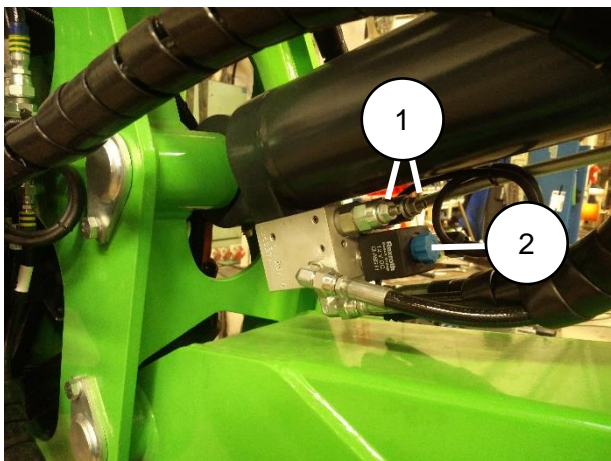

Figure 28 Upper boom cylinder

All boom cylinders (except master levelling cylinder) are equipped with load control valves (1) which prevent boom movements in case e.g. a hydraulic hose fails.

When using electric emergency lowering (see 6.2) (option) of the booms, the electric solenoid (2) valve in the cylinder opens and oil flows through the adjustable restrictor valve into the tank allowing the booms to lower.

9.12 Overload control components



Overload control has been set to the correct values at the factory and it is strictly forbidden to change its settings. FALLING HAZARD!

Overload control mechanism is located between the working platform and the platform support (Figure 27). Basket load is measured with a load sensor (1) which follows EN 280 -standard.

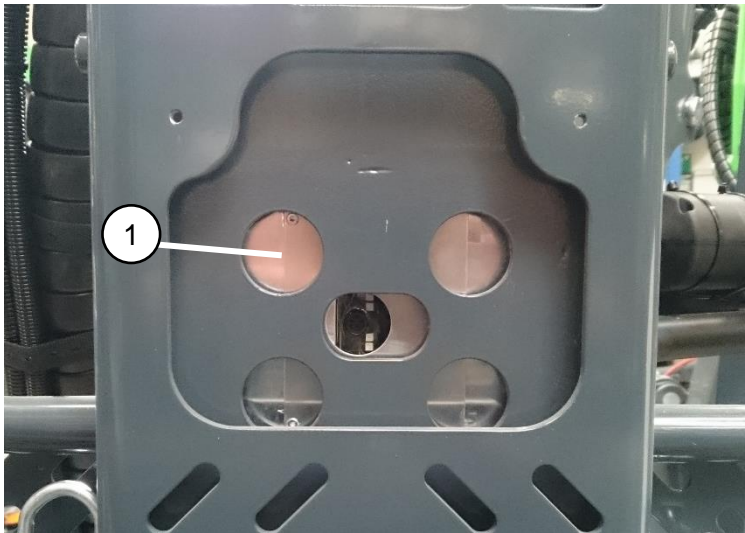

Figure 29: Load cell unit MOBA MRW

Maximum platform load has been adjusted to 230 kg.

In an overload situation the use of booms is prevented and you will hear a sound alarm and see a red indicator light in the lower (Figure 6 (6)) and upper control (Figure 5 (7)) panels.

- Remove excess load from the platform.
- Both alarms will go OFF.
- Use of booms is possible again after removing the load from the platform.

The load sensor should be checked regularly for physical damage. Damage might cause incorrect sensor values. If the sensor has to be replaced due to faults or damage, the bolts should be tightened to 150 Nm.



NEVER OVERLOAD THE MACHINE!

9.14 Boom transport support sensors

The lower transport support sensor S10 is located in the rear side of the chassis behind a cover (Figure 30 (1)).

When the 1st boom is on the transport support:

- Sensor face should face the narrowed section of the pin.
- The led lights in the sensor **MUST NOT BE ON.**

When the 1st boom is lifted from the support:

- The led lights in the sensor **MUST BE ON.**
- If the leds don't light up, adjust the sensor's horizontal position (correct distance to the pin is approx. 3 mm).
- Tighten the two nuts, **DO NOT OVERTIGHTEN.**
- **The sensor must not touch the pin.**
- After adjusting ensure the led lights in the sensor will go OFF when the boom is lowered in the transport support.

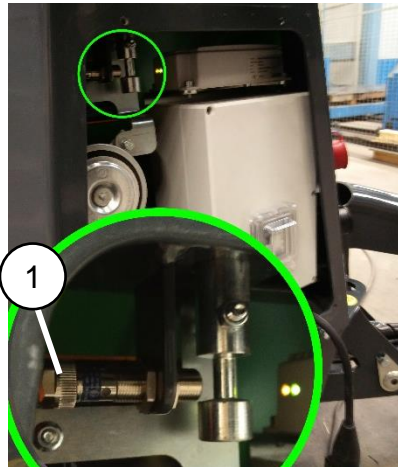

Figure 30: Lower boom transport support

The upper transport support sensor is located in front of the platform near the top of the linkage piece. It is protected by a protective plate and it is not visible from the platform (Figure 31). The sensor is adjusted according to the instructions above.



Figure 31: Upper transport support sensor

The third sensor monitoring the transport position is the jib boom sensor (Figure 32). The sensor measures whether the jib boom is in transport position or not. The sensor is located at the tip of the telescope boom on the top surface. The sensor is adjusted like the two sensors before. When the jib boom is in transport position the sensor should be facing the notch on the boom. The led-light on the sensor should not be lit when the boom is in transport position.

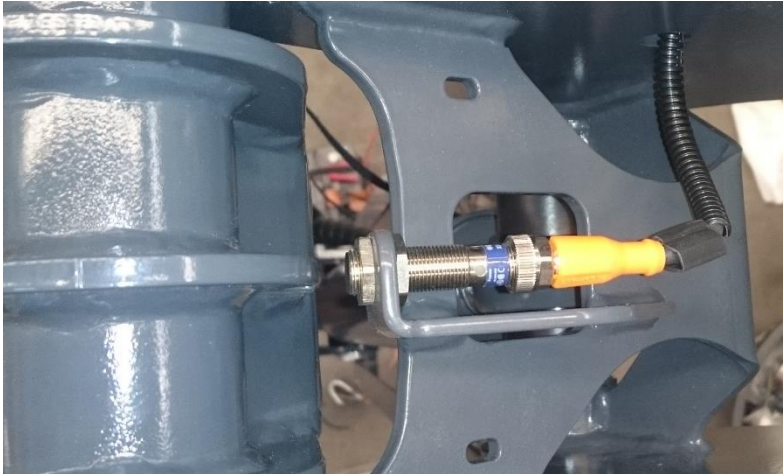

Figure 32: Jib boom sensor

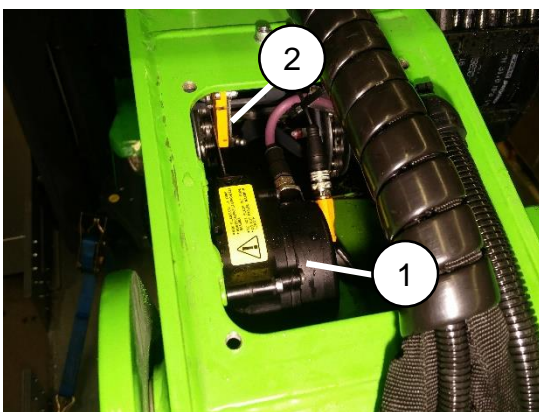

Figure 33: Upper boom sensor

Upper boom angle and telescopic boom outreach is monitored with a sensor which is located inside the upper boom located in the front side of the access platform (Figure 33 (1)). The condition of the outreach sensing cable is monitored by a capacitive sensor (Figure 33 (2)).



Figure 34: Inclination sensor

Chassis inclination sensor is located on top of the chassis next to the slewing ring. No adjustment needed.

9.15 Safety valve test

The safety valve of this access platform must be tested annually. Lifespan of the component is 30 years. After that the component must be replaced.

When testing the component it is crucial to detach entire solenoid with the cable and the socket attached. The logic controller of the unit will mistake the loose socket as a broken wire and will prevent testing.

1. Start the electric motor, make sure all booms and outriggers are in their transport positions, **and leave the motor running.**
2. Test all boom movements (also in the lower controls).
 - Boom operation must not be possible.
3. Drive outriggers against ground and level the access platform. Green indicator light must be lit. If the green light is not ON (see 5.4.).
4. Test all boom movements (also in the lower controls).
 - Boom operation must work normally.
5. Lower all booms on their transport supports.
6. **Test the safety valve K92.**
 - Make sure the lower controls are selected, all **outriggers are firmly against ground and the green boom operation allowed light is lit** (Figure 5 (5)).
 - Test that boom movements work in lower controls panel.
 - Lower all booms on their transport supports.
 - Open the bottom plate of the chassis and release the solenoid on the safety valve (Figure 24 (7)) by releasing the plastic nut and pulling the solenoid out.
 - **Test boom operation → Boom movements must not work.**
 - Put the solenoid back.
 - Ensure boom movements will work.
 - Tighten the plastic nut and close the bottom plate of the access platform.
 - Return all booms and drive outriggers in their transport positions.
 - Stop the motor.

In case the machine does not function as described in steps 1-6 the safety valve is defective. All defective valves must be replaced with new valves and the safety valve check carried out before continuing operation on the machine.

9.16 Battery handling

- Battery contains corrosive sulfuric acid – handle the battery with care! When handling the battery wear protective clothing and eyewear.
- Avoid contact with clothes or skin; if electrolyte gets on your skin or clothes flush with a lot of water.
- In case of contact with eyes, flush with a lot of water for at least 15 minutes and call a doctor immediately.
- Do not smoke when handling the battery.
- Do not touch the battery terminals or cables with tools that may cause spark emissions.
- In order to avoid spark emissions always disconnect the (-) cable first and connect it last.

9.17 Handling of fuel and oil products

- Do not let any oil leak on the ground.
- Use oil qualities recommended by the manufacturer. Do not mix different oil types and/or brands with each other.
- When handling oil always wear appropriate protective equipment.
- Before refueling always stop the combustion engine / electric motor and disconnect from mains current.
- Only use fuels recommended by the engine manufacturer. Do not mix any additives with the fuel.
- If fuel or oil gets into eyes, mouth or open wound, clean immediately with a lot of water or designated fluid and call a doctor.

Check hydraulic hoses and components only when the engine is stopped and with pressure released from the hydraulic system. Do not operate the machine if you have noticed faults or leaks in hydraulic system. Ejection of hydraulic fluid can cause burns or penetrate the skin and cause serious injuries. Consult a doctor immediately if hydraulic fluid penetrates your skin. Wash carefully with water and soap any body part that has come in contact with hydraulic oil. Hydraulic oil is also harmful to the environment – prevent oil leakages. Only use hydraulic oil type approved by the manufacturer.

Never handle pressurized hydraulic components, because in case of failure on a fitting or component ejection of high pressure hydraulic fluid can cause tipping over of the machine and serious injuries. Do not operate the machine if you have noticed a fault in the hydraulic system.



Check hydraulic hoses for eventual cracks and wear. Follow the wear of the hoses and stop operation if the outer layer of any hose has worn out. Check routing of the hoses, adjust the hose clamps if necessary in order to prevent chafing. Hydraulic hoses have finite service life and the expiration date is marked on the hoses. After that they have to be changed. If there are signs of oil leakage, put a piece of cardboard under the probable leakage place in order to find the leakage.

If you find a fault, operation of the access platform must be stopped immediately and the hose or the component must be replaced. Contact Leguan service.

10. REPAIR INSTRUCTIONS

10.1 Welding

All load carrying steel parts are manufactured from S650MC (EN 10149-2) sheet, S420MC EN10149 sheet and S355J2H EN10219 tubular pipe.



Welding repairs are only allowed to be carried out by professional welders. When welding, use only methods and additives suited for above mentioned steel qualities.

SFS EN-ISO 5817 quality level D of imperfections in welding is suitable for all weldings, except for load carrying parts.

Repair weldings in load carrying parts can be performed only by permission from the manufacturer.

Before welding:

- Remove and cover the plus (+) and minus (-) terminals of the battery.
- Disconnect all contacts of the logic controllers (picture 32). Connect the earth terminal of the welding device directly to the part to be welded.
- Do not touch the controller or electric cables with the welding electrode or the earth terminal of the welding device.

ATTENTION! It is not allowed to change the construction and structure of this access platform without a written permission from the manufacturer.



Picture 32. Contacts to the logic controllers (2 pcs)

11. INSTRUCTIONS FOR TEMPORARY STORAGE

- The cable of the + pole of the battery should be disconnected, if the access platform is being stored for a period longer than one month.
- The access platform shall be covered and, if possible, stored inside or under a roof in a place where unauthorized persons don't have access.
- Make sure possible leaks during storage will not cause waste water or similar environmental issues.
- After long storage period perform necessary checks and maintenance routines according to the service schedule.

ATTENTION! See also engine manufacturer's instructions for the storage of the engine.

12. INSTRUCTIONS FOR DISPOSING THE ACCESS PLATFORM

When the access platform's lifecycle comes to an end, it has to be disassembled and disposed of in an environmentally friendly way.

- Battery and other electronic components should be recycled or disposed of according to local regulations.
- Oil should be collected and recycled according to local regulations.
- Plastic parts should be recycled according to local regulations.
- Metal parts should be recycled according to local regulations.

13. TROUBLE SHOOTING

Following table shows eventual failures and malfunctions of the access platform and the ways how to repair them.

ISSUE	REASON	CORRECTIVE ACTION
<p>Motor will not start when the start button is pressed.</p> <p>(combustion engine or electric motor)</p>	<p>Emergency stop button is active.</p> <p>Ignition key switch is in "0" -position or different control position is selected.</p>	<p>Release all emergency stop buttons.</p> <p>Select correct control position.</p>
<p>Combustion engine does not start when start button is pressed.</p> <p>(See also engine manufacturer's Operators Manual.)</p>	<p>Motor is too cold.</p> <p>Fuel tank is empty.</p> <p>Empty start battery.</p> <p>Burnt fuse.</p> <p>Issue in fuel delivery.</p> <p>Issue in air intake.</p> <p>Start button broken.</p>	<p>Restart the engine, use maximum glow time (see 5.1.1).</p> <p>Refill (see 9.4).</p> <p>Charge battery by connecting 230 V or use jumper cables (option), replace battery if necessary.</p> <p>Replace fuse (see 0).</p> <p>Check fuel tank, fuel lines, fuel filter and fuel pump.</p> <p>Clean air filter with compressed air, replace if necessary.</p> <p>Check wiring, replace button.</p>
<p>Electric motor does not start when start button is pressed.</p>	<p>Mains cable is not connected to network.</p> <p>Empty battery.</p> <p>Burnt fuse.</p> <p>Start button broken.</p>	<p>Connect 230 V / 16 A wall socket.</p> <p>Charge battery by connecting 230V or use jumper cables (option), replace battery if necessary.</p> <p>Replace fuse (see 0).</p> <p>Check wiring, replace button.</p>

ISSUE	REASON	CORRECTIVE ACTION
<p>Electric motor stops suddenly during operation.</p>	<p>Power failure.</p> <p>Emergency stop button is active.</p> <p>Electric motor thermal overload relay (F41) in connection box has gone off.</p> <p>Burnt fuse.</p> <p>Connection fault in mains or 12 V wiring.</p>	<p>Lower the booms by using the emergency lowering. Check that there is current in mains.</p> <p>Release all emergency stop buttons.</p> <p>Wait for approx. 5 min and start the motor – the relay will return to ON automatically. Find out the reason for overload.</p> <p>Replace fuse (see 0).</p> <p>Check voltages and wirings.</p>
<p>Movements don't work even though the combustion engine / electric motor is running.</p>	<p>Failure in hydraulic system – e.g. hydraulic pump broken.</p> <p>Overload on platform.</p>	<p>Check hydraulic pressure. If there is no pressure check function of hydraulic pump safety valve</p> <p>Remove overload.</p>
<p>Combustion engine / electric motor stops when booms are lifted from transport support.</p>	<p>Outriggers are not correctly deployed down to support position – green indicator lamp is not lit.</p>	<p>Lower the booms down to transport supports with emergency lowering, restart the combustion engine / electric motor and deploy the outriggers properly so that the green indicator lights up.</p>
<p>Boom(s) come down by itself.</p>	<p>Dirt in load control valve or defective valve.</p> <p>Dirt in emergency lowering valve or defective valve.</p> <p>Cylinder seals faulty.</p>	<p>Clean valve with compressed air, if that doesn't help change valve.</p> <p>Clean valve with compressed air, if that doesn't help change valve.</p> <p>Change cylinder seals.</p>

ISSUE	REASON	CORRECTIVE ACTION
<p>Outrigger gives in.</p>	<p>Make sure that the ground doesn't give in.</p> <p>Air in outrigger cylinder(s).</p> <p>Dirt in load check valve or defective valve.</p> <p>Faulty outrigger cylinder seals.</p>	<p>Put extra support plates under the outriggers or move the machine to another place.</p> <p>Drive outriggers up and down a couple of times.</p> <p>Clean valve with compressed air, if that doesn't help change valve.</p> <p>Change cylinder seals.</p>
<p>Platform tilts backward by itself when booms are down on transport supports.</p>	<p>Air in hydraulic system.</p> <p>Dirt in load control valve or defective valve.</p> <p>Cylinder seals faulty.</p>	<p>Start the combustion engine / electric motor, drive the platform to extreme end positions. If this doesn't help, do the air bleeding of the platform self levelling system (there are bleeding screws in the self levelling cylinders).</p> <p>Clean valve with compressed air, if that doesn't help change valve.</p> <p>Change cylinder seals.</p>
<p>Automatic leveling does not work, the access platform will level the chassis but booms are not operational. The green light does not blink.</p>	<p>One of the four outriggers is not firmly against ground or the outrigger limit switch is defective.</p>	<p>Ensure all outriggers are properly deployed, check outrigger sensors (see 9.8).</p>
<p>Automatic leveling does not work, the access platform will level the chassis but booms are not operational. The green light is blinking.</p>	<p>The chassis is not levelled, issue with the levelling sensor on the chassis.</p>	<p>Re-level the access platform, check level sensor.</p>
<p>All outriggers firmly against ground. The green light does not blink and the fault light blinks.</p>	<p>Issue with the automatic leveling.</p>	<p>Drive outriggers off the ground, re-level, check outrigger sensors if necessary (see 9.8).</p>
<p>Booms on their transport supports, the green transport support light is not on and the fault light is blinking. Outriggers will not operate.</p>	<p>Issue with outrigger sensor.</p>	<p>Ensure all outriggers are properly deployed, check outrigger sensors (see 9.8).</p>

ISSUE	REASON	CORRECTIVE ACTION
Booms on their transport supports the green transport support light is not on and the fault light not on outriggers will not operate.	Booms not properly on the transport supports.	Lift the booms a little and return to their transport supports.
Booms lifted from the transport support, upper boom will not lower.	Telescope outreach sensor wire broken, boom angle sensor broken, load cell unit broken, too much inclination on the chassis.	Lower the boom using emergency lowering procedures (see 6).
Booms on their transport supports, green transport support light not on, fault light on, outriggers will not operate.	Telescopic boom not entire in, boom transport supports not properly adjusted.	Make sure all the booms including the telescopic boom are on their supports, check transport support sensor adjustments (see 9.14). Contact Leguan service.
Motor will not start, fault light, outreach light and overload light on.	Emergency stop button is active (telescope angle sensor defective).	Release all emergency stop buttons, contact Leguan service.
Overload signal light blinking.	Load cell reading negative (-50 kg or more).	Make sure the platform sits freely and does not lean on anything. Contact Leguan service.
Drive functions work intermittently.	Booms not properly on their transport supports.	Lower the booms properly on their transport supports check adjustments of the sensors (see 9.14).
Motor will stop when another control position is selected.	Correct action.	

14. PERFORMED SERVICE

It is advisable to write down all service operations that are included in the periodical service. All services that have been made during the warranty period must be noted on the list below, otherwise **the manufacturer's warranty will void**. The service operations mentioned in the maintenance schedule on chapter (see 9.1) shall be noted as follows: **First Service (50 hours), 100 hour service, 200 hour / 1 Year service etc.**

#	Date (dd.mm.yyyy)	Operating hours	Type of service (eg. first service)	Notifications, additional repairs etc.
1				
2				
3				
4				
5				
6				
7				
8				
9				
10				
11				
12				