

DOSKO

M2961040BOEC.1

MODEL NUMBER: 2961040BOE,
2961050BOE

SERIAL NUMBER: _____

Owner's Manual

Instructions for Operation, Maintenance

Self-Propelled Stump and Root Grinder 2961040BOE (691SP-20HE) & 2961050BOE (691SP-25KE)

Your Dosko grinder is intended for outdoor-use only and can be used to remove tree stumps and exposed root systems close to ground level. By moving the wheel in sweeping movements laterally over the top and front of the stump, you can gradually grind it away. Make sure you completely read and understand this manual before using the grinder for the first time.

WARNING

READ and UNDERSTAND this manual completely before using the grinder! Failure to properly operate, and maintain this grinder could result in *serious injury or death* to the operator or bystanders. All machines have hazards associated with their operation. This stump grinder has certain special hazards, which you must be aware of. As an operator or owner you have a duty to be aware of these hazards and know preventive measures to take to avoid them. When reading this manual pay particular attention to avoiding these hazards.

In particular, be aware of the following:

- Know location of buried electrical and other utility lines.
- Do not allow children or untrained adults to operate.
- Wear eye protection and other personal protection against flying rocks and debris.
- Check that cutter wheel teeth are secured, sharp and not missing.
- Do not operate if operator presence bar fails to stop engine upon release.
- Make sure no children or bystanders are within 23 meters of stump grinding operation.
- Protect cars, windows and other objects within 23 meters from flying debris.
- Be prepared for machine "kickback" when initially contacting the stump.
- Be aware of potential for carbon monoxide (CO) poisoning.
- Prevent fires/explosions from fueling.
- Do not attempt to perform adjustments, declog or clean unit while engine is running.
- Avoid burns from engine or hot exhaust.
- Avoid using in wet or icy conditions where falls may occur.

Details about these hazards are found throughout the manual and are summarized at the end of the manual under "Important Safety Information."

STOP!

ADD ENGINE OIL, FUEL & BATTERY: Your stump grinder comes fully assembled and requires only that you add engine oil to crankcase, fuel to tank, and a battery.

INSPECT COMPONENTS: Closely inspect to make sure no components are missing or damaged. See the "Receiving Your Unit" section for instructions on whom to contact to report missing or damaged parts.

Any Questions, Comments, Problems, or Parts Orders
Call your dealer or Dosko Customer Service 1-763-428-2237

Hazard Signal Word Definitions





	<p>This is the safety alert symbol. It is used to alert you to potential personal injury hazards. Obey all safety messages that follow this symbol to avoid possible injury or death.</p>
	<p>DANGER (red) indicates an imminently hazardous situation which, if not avoided, will result in death or serious injury.</p>
	<p>WARNING (orange) indicates a potentially hazardous situation which, if not avoided, could result in death or serious injury.</p>
	<p>CAUTION (yellow) indicates a potentially hazardous situation which, if not avoided, may result in minor or moderate injury.</p>
	<p>CAUTION (yellow) used without the safety alert symbol indicates a potentially hazardous situation which, if not avoided, may result in property damage.</p>

fig01453

Table of Contents

Part I. Introduction

About Your Grinder	5
Safety Decal Locations	6
Safety Decals	7
Transporting & Receiving:	
1. Receiving Your Unit.....	8
Machine Component Identification	9

Part II. Operation

Operation:	
1. Pre-Start Check List & Procedures	10
2. Starting the Grinder.....	13
3. Stopping Engine.....	14
4. Moving the Grinder.....	15
5. Grinding the Stump.....	15
6. Refueling.....	17
7. Storing the Grinder	18

Part III. Maintenance and Repair

Maintenance (To be done by owner or Rental Dealer)	20
1. Belt Tension Adjustment	22
2. Hydrostatic Drive.....	23
3. Electric Clutch Engagement	23
4. Stop-Switch Adjustment	24
5. Setting & Sharpening Teeth.....	24
6. Schedule.....	26
Specifications	27

Part IV: Important Safety Information

Summary of Important Safety Information for Operation	28
Special Safety Information on Static Electricity	31

Parts Explosion	32
------------------------------	----

Wiring Diagrams	34
------------------------------	----

Warranty	36
-----------------------	----

About Your Grinder

Thank you for purchasing or renting your Dosko grinder!

Owner/Operator/Renter Training

Read and follow all instructions and safety precautions presented throughout this manual. A summary of important safety information can be found at the end of the manual. Keep this manual for reference and review. **If the owner of this unit is different than the operator, give a copy of this manual to any operator to read.**

Rental Companies

All persons to whom you rent/loan this grinder must have access to this manual and read it. Check the tube on the side of the unit to make sure a manual is inside. Advise all persons who will operate the machine to read it. You should also provide personal instruction on how to safely operate the grinder and remain available to answer any questions a renter/borrower might have. If videos are available, have renter watch training video.

Engine Instructions

For detailed Engine operation and maintenance information, always refer to the engine Owner's Manual furnished with the grinder.

Product Suitability

Before using, the user shall determine the suitability of this product for this intended use and assumes liability therein.

Your Dosko grinder can be used to remove many tree stumps and exposed root systems close to ground level. By moving the wheel in sweeping movements laterally over the top and front of the stump, you can gradually grind it away. Make sure you completely read and understand this manual before using the grinder for the first time. If you have any questions, contact your retail or rental dealer or Dosko Customer Service at 1-763-428-2237.

▲ WARNING: Never attempt to cut on a slope exceeding 15°.

Exercise caution when cutting stumps on an incline, as the machine may shift or slide unpredictably. Never attempt to cut with the machine uphill or downhill from you as it may slide toward you or you may fall toward the machine. Cut only on a slope from the side.

Dosko is constantly improving its products. The specifications outlined herein are subject to change without prior notice or obligation. The purchaser and/or user shall assume liability for any modification and/or alterations of this equipment from original design and manufacture. Any alterations shall void warranty and CE Certification.

Contact Dosko Customer Service at 1-763-428-2237 for any questions about the appropriate use of this grinder or about optional accessories.

Warranty Registration

Please fill out and submit the warranty registration card so that we have your contact information for any future product literature or replacement parts you may need.

Safety Decal Locations

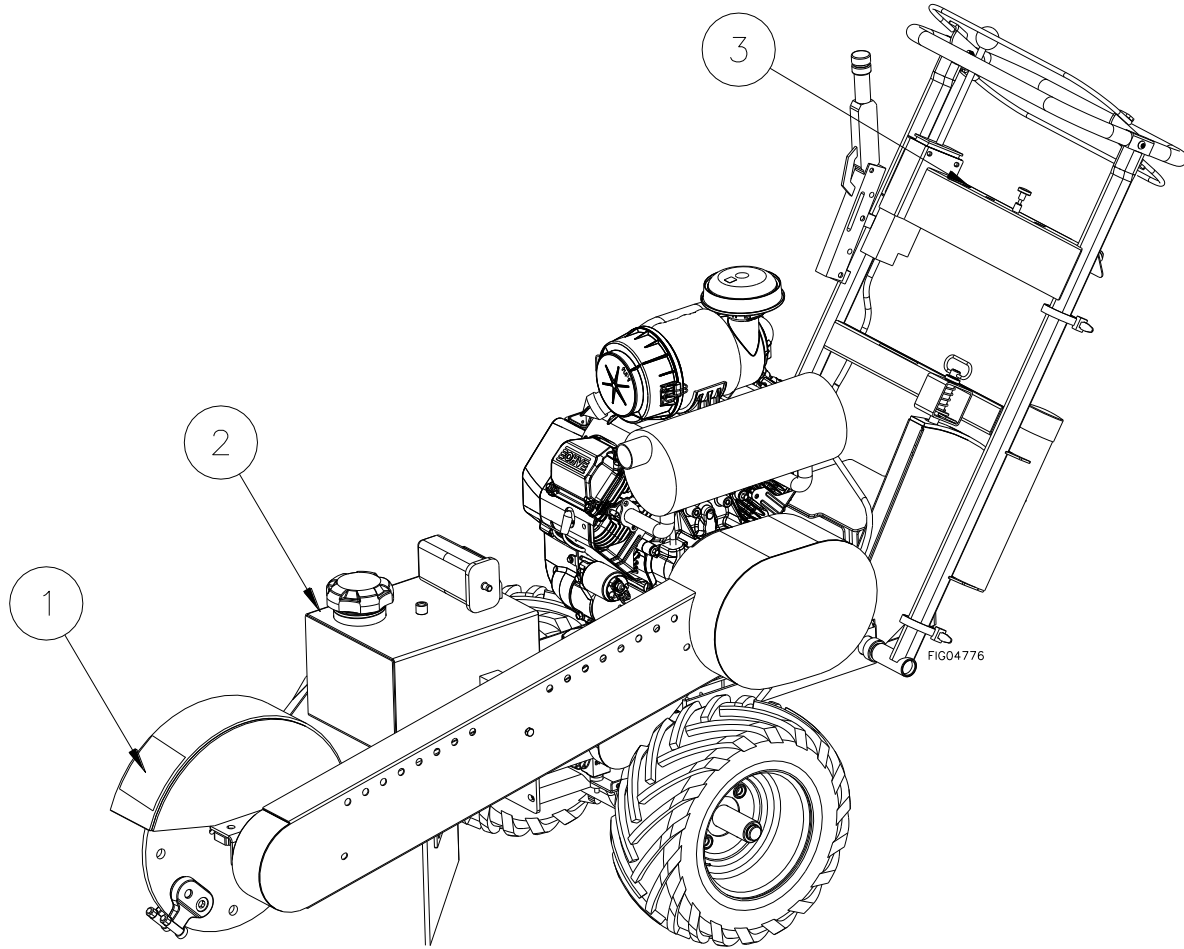

Reference #	Part #	Description	Model #
1	789537	Cut Foot Hazard	All
2	789538	Thrown Object Hazard	All
3	789665	Control Panel	691SP-20HE
	789536		691SP-25KE

⚠ WARNING

ALWAYS make sure safety labels are in place and in good condition. If a safety label is missing or not legible, order new labels.

Safety Decals

1 789537



A

2 789538



B

3 789665

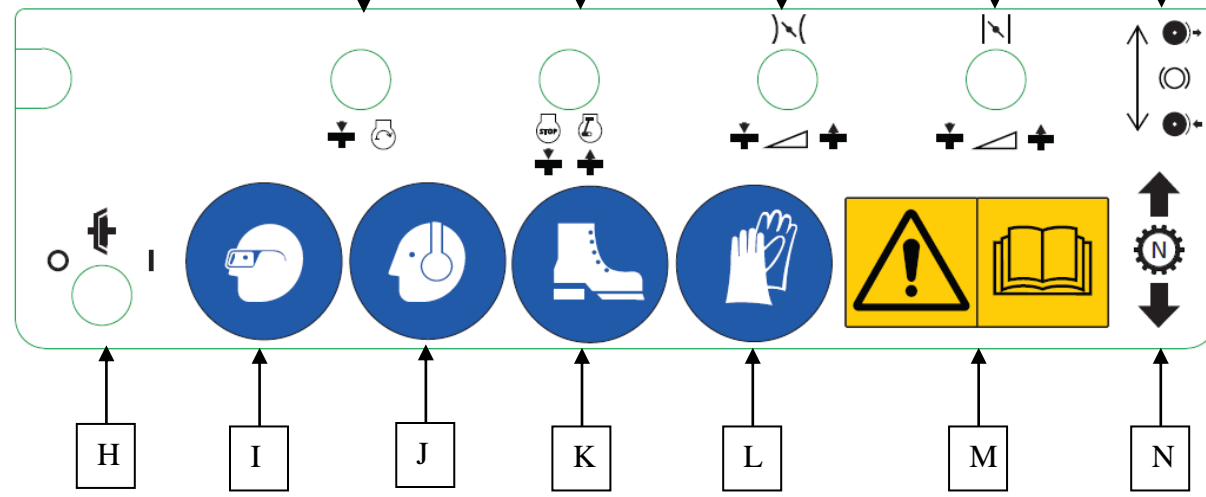

C

D

E

F

G

H

I

J

K

L

M

N

Safety Decals

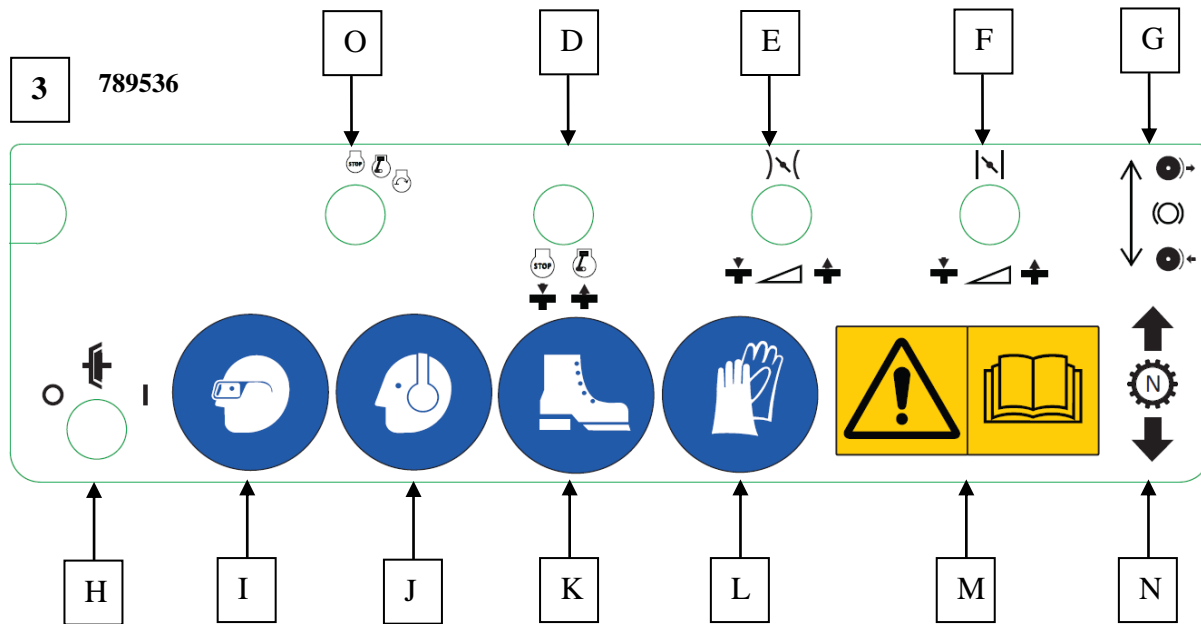

Ref.	Description
A	Cutting hazard to foot. Keep distance.
B	Thrown object hazard. Keep distance.
C	Push to start.
D	Push to stop. Pull to run.
E	Pull to increase throttle. Push to decrease throttle.
F	Pull to increase choke. Push to decrease choke.
G	Move control forward to disengage brake. Move control backward to engage brake.
H	Turn clutch off by turning the switch to the left or on by turning the switch to the right.
I	Wear eye protection while operating.
J	Wear ear protection while operating.
K	Wear protective footwear while operating.
L	Wear gloves while operating.
M	Hazards exist. Read manual before operating.
N	Move control in indicated direction to move stump grinder in same direction.
O	Move key to point up to stop. Move key to right to run. Move key to far right to start.

To order replacement safety labels, call Dosko Customer Service at 1-763-428-2237.
 All grinder units can be transported via trailers.

Transporting and Receiving

1. Receiving Your Unit	
For all Units	<p>You should inspect the grinder immediately after you receive delivery. <i>See the "Machine Component Identification" section of this manual for a diagram of the grinder and its components.</i></p> <ul style="list-style-type: none"> • If you have <i>missing</i> components, contact your rental company or Dosko Customer Service at 1-763-428-2237.
New Unit: Truck Delivery	<p>Depending on your unit and model, it may have been shipped on a wooden skid, cardboard container or other appropriate method.</p> <ul style="list-style-type: none"> ◆ For any shipping damage, make sure the delivery driver acknowledges it and a claim is filed with the freight delivery company. Note: <i>Shipping damage claims are not covered by Dosko warranty. Please contact carrier!</i> ◆ If any assembly is required. Separate assembly instructions will be included.
New Unit: From a Dealer	<p>Your unit should have been delivered completely assembled and ready to run. Read the "<i>Operation: Preparing for Operation</i>" section (page 9), and verify that the unit has been properly "prepped" before initial use.</p>
Factory Delivery	<p>In these cases, your unit has been completely assembled, tested and pre-run. It should be ready for usage. See "Pre-Start Checklist and Procedures".</p>

Machine Component Identification

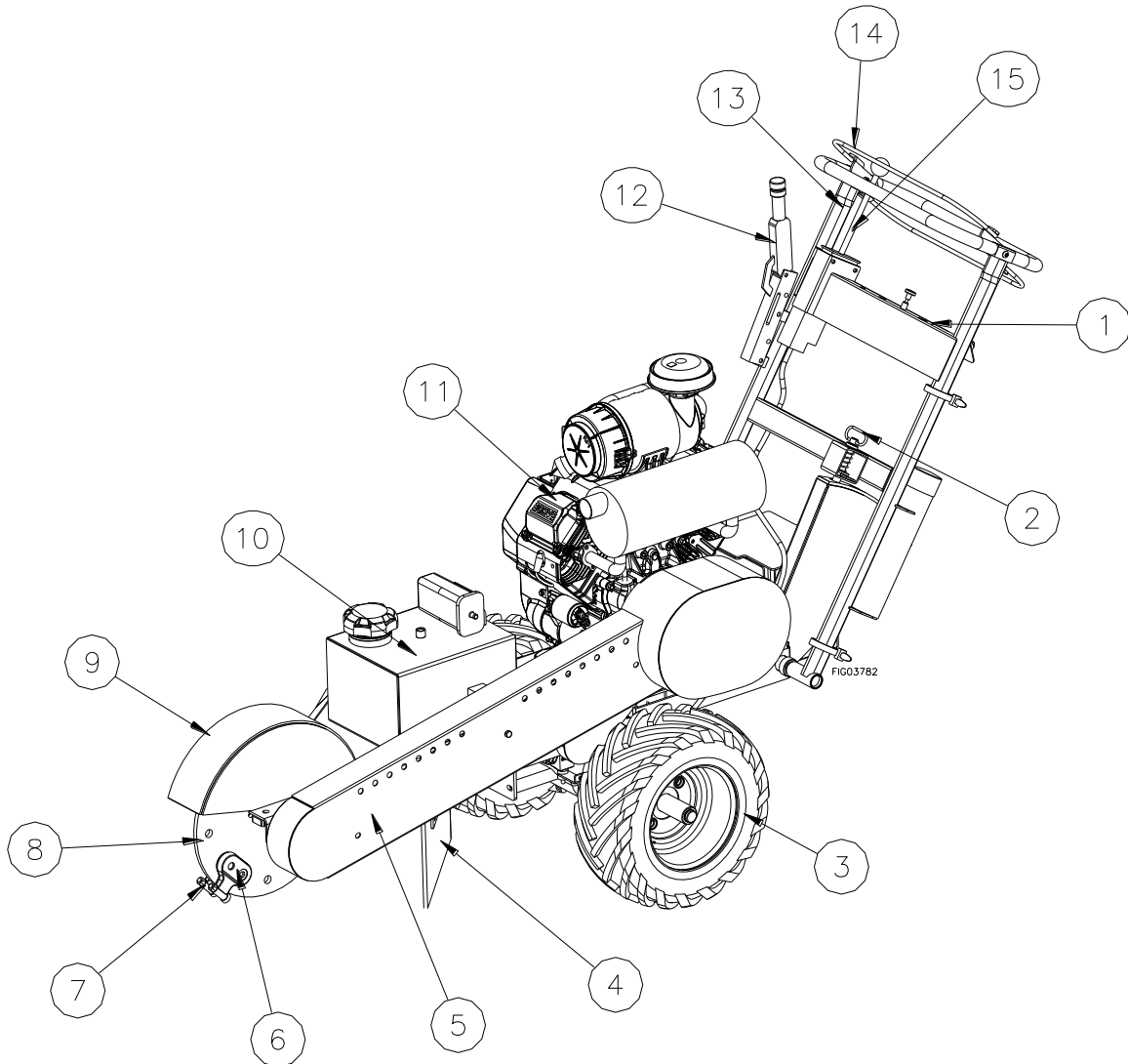

Reference #	Description
1	Control Panel
2	Pin Adjustment Handle Bar
3	Tire and Hub
4	Discharge Flap
5	Belt Guard
6	Tooth Pocket
7	Cutting Tooth
8	Cutter Wheel Disc
9	Cutter Guard
10	Gasoline Tank
11	Engine
12	Adjustable Brake Lever
13	Handle Bar
14	Operator Presence Handle Bar
15	Direction Control Lever

Operation

1. Pre-start Check List & Procedures

⚠ CAUTION:

Add engine crankcase oil. A new engine is shipped without oil. You must add the correct amount of oil to engine crankcase or engine will be damaged beyond repair.

Before starting the engine you will want to make sure you have completed the following:

1. **Marking Underground Utilities**
2. **Checking Controls**
3. **Checking/Adding Oil**
4. **Filling Stump Grinder Gasoline Tank**
5. **Inspecting Fuel System for Leaks**
6. **Adjusting Handle Bar**
7. **Wearing Personal Protection**
8. **Trimming Stump with Saw**
9. **Clearing Area of People and Objects**
10. **Working During Daylight**
11. **Battery Installation**

Each of these procedures is discussed in detail below.

Marking Underground Utilities	Call your local utility company to request marking utilities 3 days before stump grinding. Trees can grow on top of and around underground wiring that was installed many years before a tree was planted.
Check Controls.	<p>Check that:</p> <ul style="list-style-type: none"> • All guards are in place and tight • Operator presence bar switch is free moving. • Inspect tires and rims for looseness, damage, and tire inflation.
Check Cutting Teeth	Inspect cutting teeth for tightness and sharpness. Only use factory-approved parts for repair.
Check/Add Oil	<p>Check the oil level using the dipstick and add oil as needed daily.</p> <p>Using a funnel, add oil up to the FULL mark on the dipstick with the recommended oil type for your engine and expected ambient conditions. (See engine Owner's Manual for oil type and capacity, and more detailed oil check/fill instructions.)</p> <p>⚠ WARNING: Burn hazard Never open oil fill port while engine is running. Hot oil can spray over face and body.</p>

Operation (cont'd)

<p>Fill Stump Grinder Gasoline Tank</p>	<p>Check the gasoline level in the grinder's gas tank. If needed, fill tank with fresh unleaded gasoline from a portable container, after first reading the warnings and instructions below.</p> <ul style="list-style-type: none"> - Do NOT fill the gas tank to the top. Gasoline may spill when operating on a slope. - Do NOT overfill the gasoline tank. Allow at least 2.5 cm of empty space below the fill neck to allow for fuel expansion. <p>⚠WARNING: Gasoline fire/explosion hazard Gasoline is highly flammable and explosive. Heat, sparks, and flames can ignite gasoline vapors, which can become widespread during fueling. A flash fire ignition and/or explosion could result and cause serious injury or death. The following conditions could result in gasoline ignition/explosion:</p> <ul style="list-style-type: none"> • gas vapor collection inside enclosures • static electric sparks • sparks from electric wiring, batteries, or running engines • sources of heat (such as a hot engine or exhaust) • open flames, including pilot lights
<p>Inspect Fuel System / Check for Leaks</p>	<p>Inspect fuel system & check for leaks BEFORE starting grinder.</p> <p>⚠WARNING: Fuel leak hazard A leaking fuel line no matter how small can be the source of a fire or explosion when starting or operating the engine.</p> <ul style="list-style-type: none"> • Inspect the entire fuel system. <i>Look for:</i> Signs of leaks or deterioration, chafed or spongy fuel hose, loose connections, loose or missing fuel hose clamps, and a damaged gasoline tank. <p>If grinder is in an enclosed area and you smell gas, DO NOT start engine! DO NOT light a match. DO NOT flip on an electrical switch. Exit area immediately leaving doors open and call the fire department.</p>
<p>Adjust Handle Bar</p>	<p>Handle bar may have to be adjusted to accommodate for the height of stump or desired depth. When grinding above or below ground level, adjust handle bar for better control and comfort. <i>Note: Your stump grinder should not be used more than 10 inches maximum below ground</i></p>
<p>Personal Protection</p>	<p>Use approved protective clothing and approved protective equipment when using the machine.</p> <ol style="list-style-type: none"> 1) Always wear ANSI-approved and OSHA-compliant safety glasses with side shields and a full-face shield. 2) The use of ear plugs or other hearing protection device is also recommended for persons working within 4.5-5M of the running grinder for longer than a few minutes. Hearing can be damaged from prolonged, close-range exposure to the type of noise produced by this

Operation (cont'd)

	<p>grinder.</p> <p>3) Wear long pants to protect legs from sparks, hot engine and flying debris.</p> <p>4) Never wear jewelry or loose-fitting clothing when starting or operating the grinder or any mechanical device. Loose or dangling apparel, jewelry or hair can become entangled in moving parts.</p>
Trim Stump with Saw	Cut or trim the stump preferably to ground level using a power saw.
Clear Area	Dig away the earth and remove any stones near the tree stump or roots that may interfere with your work.
Work During Daylight Hours	Only use the machine in daylight or in well-lit conditions. Never operate the grinder after dark.

Battery Installation

Your stump grinder's engine is equipped with an electric starter, which requires the installation of a 12-volt lawn tractor size battery (Group U1). See the Engine owner's manual for battery rating.

The battery is to be supplied by the customer and should be installed in the protective battery box located near the engine. (The inside dimensions of the battery box are 22.5 cm L x 15 cm W x 21.5 cm H.) Follow the instructions detailed below for connecting and disconnecting the battery.

WARNING: Battery hazards

- Batteries are hazardous because they contain caustic acid, can emit explosive gases, and can cause electric shock. Caution must be exercised when making connections to a battery to avoid shock and contact with the acid, and to prevent any sparking that could lead to an explosion.
- ALWAYS follow the general battery safety rules and instructions listed below.

General Battery Safety Rules	<ul style="list-style-type: none"> • ALWAYS use eye protection when handling batteries. • NEVER smoke or work near sparks or other sources of ignition. • NEVER touch both battery terminals at the same time with your hand or any non-insulated tools. • If battery acid contacts skin or clothing, flush immediately with water and neutralize with baking soda.
Connecting the battery	<p>Always connect the cables in the following sequence to avoid possible shock:</p> <ol style="list-style-type: none"> 1. Find the battery cables located inside the battery box. 2. Connect the red cable to the positive (+) terminal of the battery. 3. Then connect the black cable to the negative (-) terminal of the battery.
Disconnecting the battery	<p>Always disconnect cables in the following sequence to avoid possible shock.</p> <ol style="list-style-type: none"> 1. First, disconnect the black cable from the negative (-) terminal of the battery. 2. Next, disconnect the red cable from the positive (+) terminal of the battery.

Operation (cont'd)

2. Starting the Grinder

After you have completed the pre-start checklist and procedures, you are ready to start the grinder.

The following directions detail how to start the engine of your grinder.

▲ WARNING:

Never attempt to use the grinder without proper protective equipment, particularly eye protection and a full-face shield.

To start the grinder:

Note: For additional engine starting instructions see your Honda/Kohler engine manual.

- 1) Before starting you should raise or lower the handle bar to a comfortable position to accommodate the height of the stump you will be grinding.
- 2) Place stump machine into position with cutting wheel near the front-top edge of the stump.
- 3) Use Brake Lever by the handle bar to lock the one wheel brake.
Note: For tighter brake adjustment, turn knob on top of brake lever. (See Maintenance and Repair section for instructions.)
- 4) Confirm Clutch on/off switch is on the OFF position.

▲ WARNING:

Stay in the OPERATOR POSITION while actuating controls. Never leave grinder unattended.

- 5) Pull Engine On/off Switch to RUN position.
- 6) For cold engine: pull choke lever to full choke position. To restart warm engine, move choke to half choke or to RUN position.
- 7) Grip Operator Presence bar & Handle bar together in left hand.
- 8) Turn Engine Key or Push Ignition Switch to the START position and hold until the engine starts.
- 9) If the engine fails to start after 5 seconds, wait 10 seconds before attempting to start again.
- 10) Release the key when the engine starts.
- 11) When engine starts, move choke lever to RUN position and turn Throttle slowly to full OPEN position.

▲ WARNING:

A rotating cutting wheel is very dangerous. Stay at the controls and keep others away until you are sure the wheel has come to a complete stop.

Operation (cont'd)

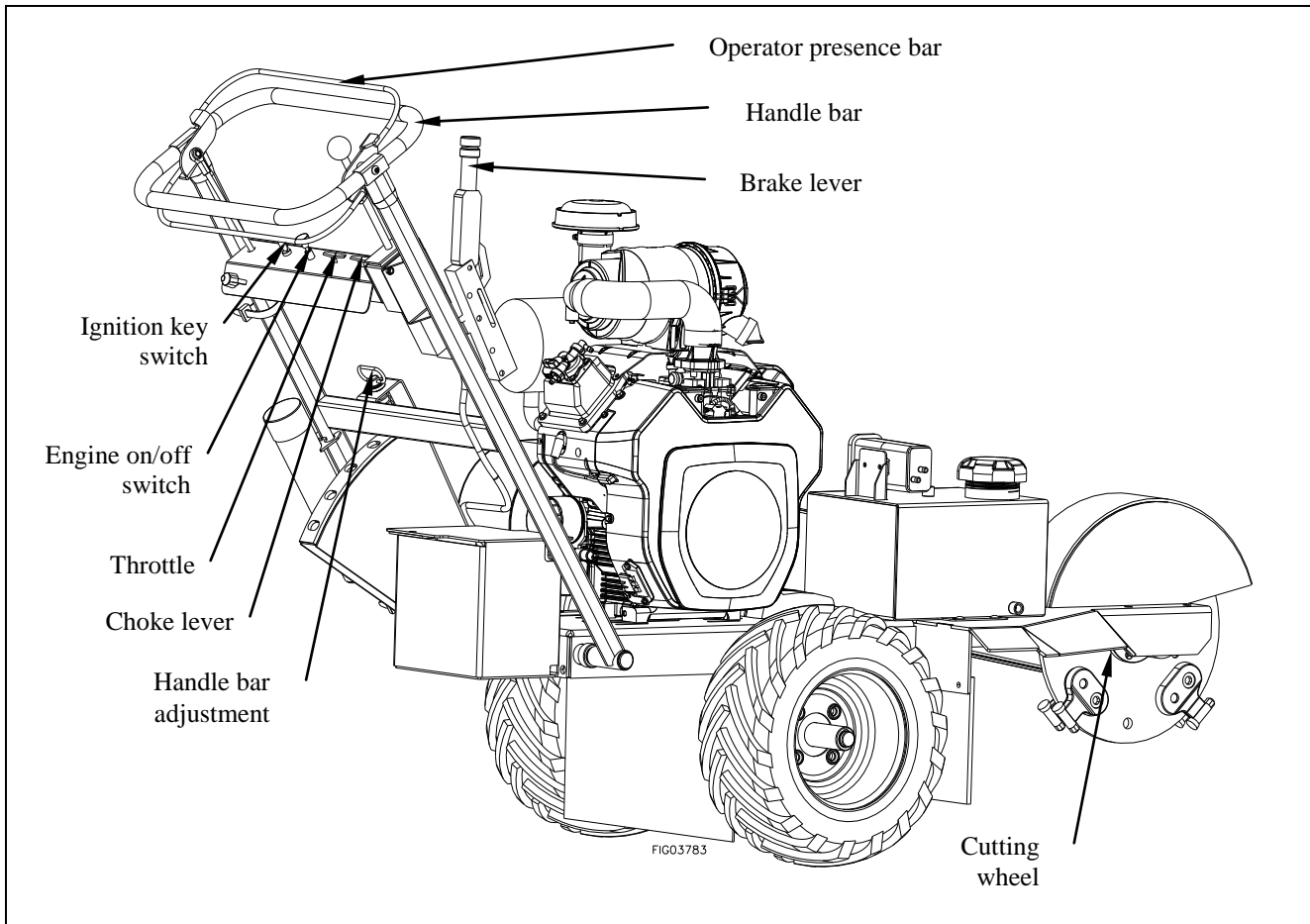

3. Stopping the Engine

Stop the engine using the following steps:

1. While holding cutting wheel off ground, release the operator presence bar, and push the Engine On/off Switch to the OFF position. Wait until the cutting wheel completely stops.
2. Use the Clutch On/off Switch to disengage clutch. Lower the cutting wheel so it is resting against the ground.
3. Use Brake Lever to set brake before leaving the controls, particularly if you are on an incline.
4. Turn Engine Key Switch to OFF position.
5. Allow the engine to cool for at least 5 minutes before releasing brake and moving to storage or transporting. A hot engine can be a fire hazard.

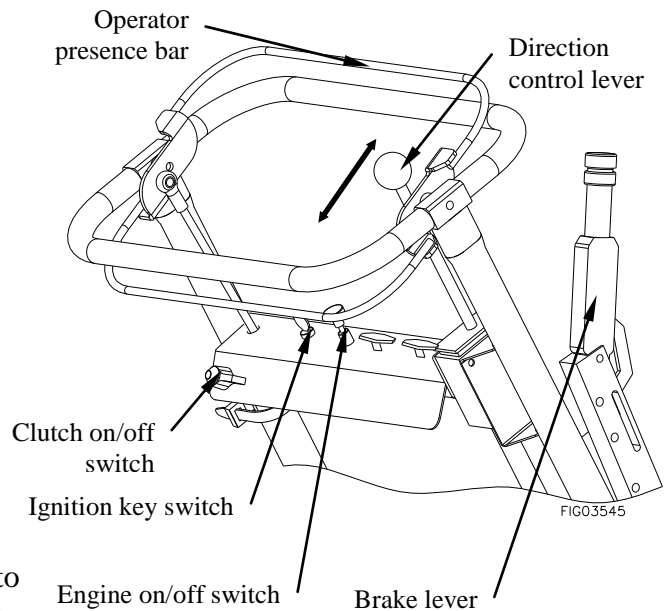

Operation (cont'd)

4. Moving the Grinder

Move the grinder using the following steps:

(Refer to illustration on previous page)

1. Start engine. See "Starting the Grinder" on page 12 & 13.
2. Release Brake Lever.
3. Pull down on Handle, raising Cutting Wheel off the ground.
4. Push Direction Control Lever ahead for forward travel and pull back for reverse travel.

5. Grinding the Stump

⚠ WARNING: Flying Debris Hazard

Stones, chips, and debris can cause serious injury or property damage. Debris can fly 23 meter in any direction out of the chute. They can bounce off any fixed objects as well and hit operator, bystanders or breakable objects.

1. Set/engage the brake.
2. Set engine to 1800 RPM (1/2 throttle).
3. With cutting wheel off the ground, turn clutch switch to ON position to engage clutch.
4. Once clutch is engaged, pull throttle full "ON" and twist to lock.
5. Pivot grinder toward the side of the stump, then lower it approximately 1.5 to 2.5 cm into the front-top corner of the stump. Slowly pivot the cutting wheel back and forth, lowering the cutting wheel approximately 1.5 to 2.5 cm before each sweep, until you have removed the front portion of the stump to ground level.

⚠ WARNING: Rotating cutter wheel.

Keep hands and feet away. Contact with wheel rotating teeth will cause serious personal injury.

6. Raise cutting wheel until center of cutting wheel is just above top of stump.
7. With cutting wheel off to one side, advance the machine horizontally by releasing and resetting the brake. Advance the machine forward to engage the cutting wheel into the stump so that when swept across the stump it will remove 1.5 to 2.5 cm of stump with each sweep.
8. Sweep the cutting wheel across the stump, cutting away 1.5 to 2.5 cm of stump.
9. Advance cutting wheel 1.5 to 2.5 cm, and sweep again across stump in opposite direction.
10. Continue sweeping cutting wheel left and right across stump, advancing it before each sweep, cutting 1.5 to 2.5 cm depth of stump with each sweep.
11. Cut complete stump flush with ground, then go back and cut to further depth, if desired.

Note: When grinding over 25 cm above or below ground, adjust handle bar for better control and comfort.

Operation (cont'd)

Chip Build-up

12. When grinding larger stumps, chips may begin to build up under the wheels.

- Release brake and pull machine towards you so that the "chip pile" is directly under the cutting wheel.
- Drop cutter wheel down on "chip pile", material will be discharged from machine area.

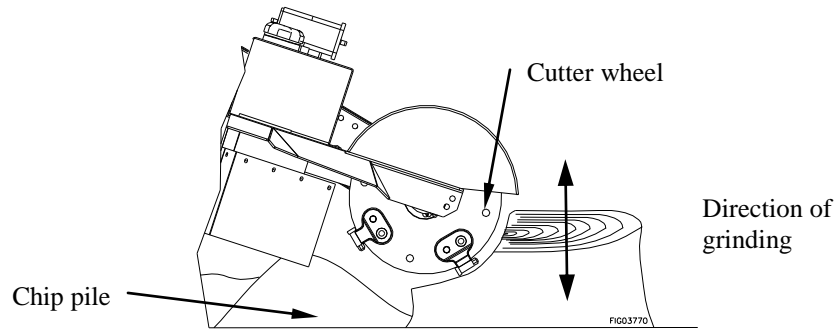

⚠ WARNING: Flying Debris Hazard

Stones, chips, and debris can cause serious injury or property damage. Debris can fly 23 meters in any direction out of the chute and bounce off objects and hit operator, bystanders or breakable objects.

- On these larger stumps, DO NOT allow grinder wheels to drop into stump hole. If a hole is in the way of your progress, fill it with chips or change position.

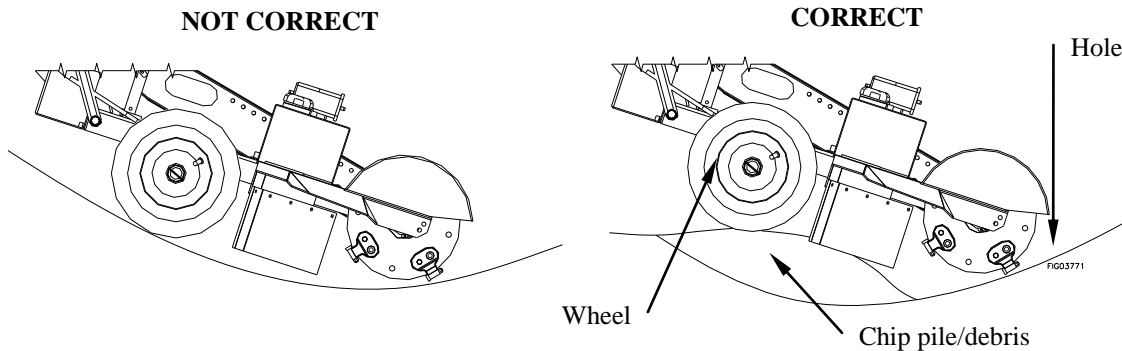

⚠ WARNING:

Stop engine and set brake before leaving operator's position. **KEEP BRAKE ENGAGED** except when changing locations.

10. When finished, stop the machine.

11. Pull machine away from stump, and rake chips away from stump.

Operation (cont'd)

6. Refueling

1. Before removing gas cap, turn engine off and allow to cool for at least two minutes.

Note: A running or hot engine can ignite fuel.

2. Remove grinder gasoline cap.
3. Add gasoline through the fill opening:
 - Use only an UL-approved portable gasoline container to transfer the gasoline to the grinder's tank.
 - Be aware of safety warning and instructions below for avoiding static electric caused fires.

▲ WARNING:

Static electric spark hazard

A static electric spark can explosively ignite gasoline vapor, resulting in a flash fire that could cause serious injury or death. See "Special Safety Information on Static Electricity" at end of this manual.

4. Clean up gasoline spills /splashes immediately.
 - If possible, move the grinder away from spilled gasoline on the ground.
 - Wipe up spilled gasoline, and wait 5 minutes for excess gasoline to evaporate before starting engine.
 - Gasoline soaked rags are flammable and should be disposed of properly.
 - If gasoline is spilled on your skin or clothes, change clothes and wash skin immediately.
5. Replace gasoline cap securely before starting engine.
6. Store extra gasoline in a cool, dry place in an UL-approved, tightly sealed container.
7. Filling self-propelled units or portable containers at service stations:

Avoid static electric sparking while filling the gasoline tank:

- Never fill the grinder's gas tank directly from the fuel pump. The grinder's tank is not grounded and high velocity flow from the pump can cause static electricity build-up. Use an approved portable container to transfer gas to the grinder's tank.
- Use a portable container made of metal or conductive plastic. This is preferred because it dissipates static charge to ground more readily.
- Never fill a portable gas container while it is sitting inside a vehicle, trailer, trunk, or pick-up truck bed. ALWAYS place container on the ground to be filled.
- Keep nozzle in contact with container while filling. Do not use a nozzle lock-open device.



Operation (cont'd)

7. Storing the Grinder

When you are finished using the grinder and it has cooled, you must:

- Cool engine before storage.
- Clean the grinder.
- Inspect for worn or damaged parts.
- Choose covered storage location.
- Prevent accidental starting.
- Plan on exercising the engine at least monthly unless the grinder is prepared for long-term storage.

Detailed instructions are provided below.

Cool engine	Let engine cool for at least five minutes before storing. A hot engine can be a fire hazard.
Clean grinder	Clean all grease, dirt, mud and other foreign matter from the machine. Touch up paint damage to prevent rust.
Inspect grinder	Inspect the machine for worn or damaged parts and tighten any nuts or screws that may have become loose. Pay particular attention to the cutting teeth.
Choose a storage location	Store the grinder in a location that is: <ul style="list-style-type: none"> ○ Clean and dry ○ Away from sources of heat, open flames, sparks, or pilot lights, even if the grinder's gas tank is empty. Residual gasoline could ignite. ○ Away from extreme high or low temperatures. ○ Covered for extra protection
Remove key	Remove key from starter and secure key in a safe location, or remove spark plug, in order to ensure the grinder cannot be started in a storage location or by untrained persons or children.
Start grinder every 4 weeks	The grinder should be started regularly. At least every four weeks, start the engine and let it run for 10 to 15 minutes. Monthly exercising of the grinder will dry out any moisture that has accumulated, lubricate cylinders, and clean out old gas in the carburetor. Moisture, old gas, and dry mechanical parts cause deterioration in stored engines.

Operation (cont'd)

Prepare engine for long term (seasonal) storage if needed

If you will not be able to start the grinder regularly, you must prepare the engine for long term storage to prevent gum deposits from forming and causing malfunction of the engine.

Prepare engine for long term storage by:

- **Removing all gasoline** from the tank and carburetor
- OR
- **Adding fuel stabilizer** to the gasoline (following manufacturer's instructions)

Fuel stabilizer steps:

1. Ensure gas tank is full.
2. Add fuel stabilizer to fuel tank.
3. Run engine at least 10 minutes after adding stabilizer to allow it to enter the fuel system.
4. Shut off engine
5. Disconnect spark plug wire and remove spark plug
6. Add one teaspoon oil through spark plug hole
7. Place rag over spark plug hole and turn starter (or pull the recoil) a few times to lubricate the combustion chamber.
8. Replace spark plug, but do not reconnect the spark plug wire.

⚠ WARNING: Gasoline fire/explosion hazard

Gasoline is highly flammable and explosive. Drain the fuel into an approved container OUTDOORS and far away from open flame. NEVER store an engine with fuel in the tank indoors or in poorly ventilated spaces where fuel vapor can come in contact with

- static electric sparks
- sparks from electric wiring, batteries, or running engines
- sources of heat (such as a hot engine or exhaust)
- open flames, including pilot lights

Maintenance & Repair

⚠ WARNING

ALWAYS shut off the engine, make sure the engine is cool, disconnect the spark plug and positive battery terminal from the battery before cleaning, adjusting, or servicing the grinder. Make sure all guards and shields are replaced before using.

Maintenance	
Perform regular maintenance	Perform periodic maintenance as directed in this manual to keep the grinder in safe working condition.
Follow safety rules	<p>Read and follow these safety rules whenever you will be servicing the grinder:</p> <ul style="list-style-type: none"> • Turn off grinder. Always turn off grinder and remove spark plug or spark plug wire, and disconnect positive battery terminal from battery on electric start models before working on the engine or grinder to prevent accidental starting. • Replace guards/shields. Make sure all guards and shields are replaced after servicing the grinder. • Burns. Muffler will be hot even after unit is stopped. Allow unit to cool before servicing. • Repair. Major service, including the installation or replacement of parts, should be performed only by a qualified electrical service technician. Obtain factory approved parts from Dosko Service at 1-763-428-2237. • Replacement parts. If a part needs replacement, only use factory approved repair parts. Replacement parts that do not meet specifications may result in a safety hazard or poor operation of the grinder and will void the warranty and CE Certification.
Perform engine maintenance	<p>Perform engine maintenance as specified in the engine owner's manual. Engine maintenance items include:</p> <ol style="list-style-type: none"> 1. Oil and oil filter changing 2. Air filter check/replacement 3. Spark plug cleaning and replacement 4. Fuel filter check/replacement 5. Fuel tank cleaning.
Inspect fuel system / check for leaks	<p>Inspect the fuel system and check for leaks on a regular basis. Look for: signs of leaks or deterioration, chafed or spongy fuel hose, loose connections, loose or missing fuel hose clamps, damaged gasoline tank, or defective gasoline shut-off valve.</p>

Maintenance & Repair (cont'd)

Lubricate

Cutter shaft bearings should be greased.

The cutter shaft bearing is greased by pumping grease into zerks located on the housing of the bearing.

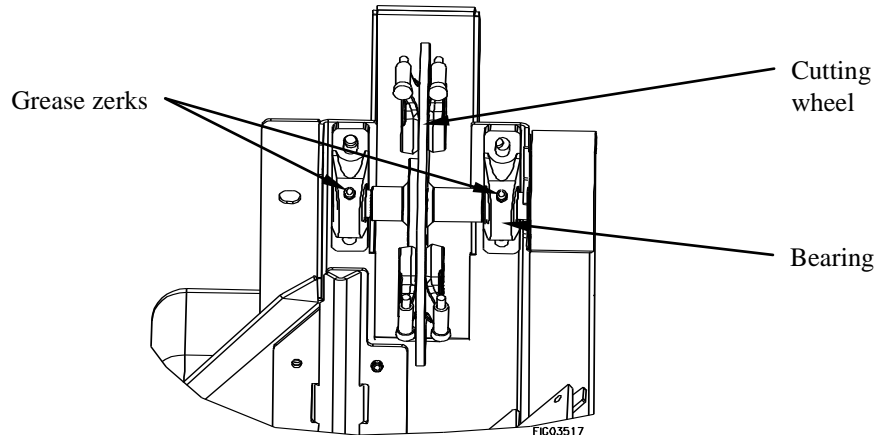

Grease Specification	
Soap Type	Lithium Complex
NLGI Grade	#2
Dropping Point	230°C (446°F)
Additives	Corrosion and Oxidation inhibitors, EP optional
Viscosity Index	80 Minimum

Check and adjust brake

Check that the brake is functioning properly.

- Lock the brake; push down on handle bar so that cutter wheel is off the ground.
- Push or pull the grinder- if the brake is loose, the wheel will rotate.

To adjust braking tension:

- Unscrew setscrew.
- Turn knob clockwise to increase tension or counter-clockwise to decrease tension.
- Once you have set the brake to the proper tension, tighten setscrew to lock adjustment knob.

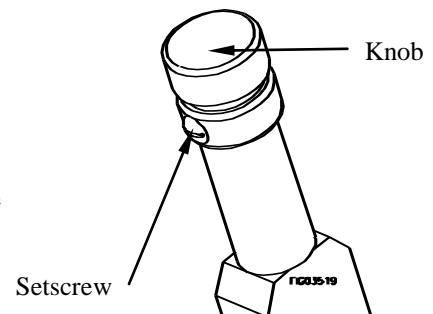

Maintenance & Repair (cont'd)

1. Belt Tension Adjustment

Note: Belt tension and alignment are inter-related. Do not adjust one without checking the other.

1. Remove belt guard.
2. Loosen hydrostatic drive belt idler.
3. Loosen (4) engine base (mount) bolts.
4. Loosen lock nut on tension bolt and alignment bolt.
5. Turn tension bolt clockwise to increase belt tension and counterclockwise to decrease belt tension.
6. Check that the pulleys are aligned using a straight edge. To achieve proper pulley alignment you may need to adjust the alignment bolt. This bolt will serve as an adjustment point to counter the tension in the belts, which may cause the engine pulley to be misaligned with the cutter wheel pulley.
7. When belt tension is proper; 15 to 19 Nm of tension, or 5 mm deflection and pulleys are aligned, retighten all loosened bolts and nuts.
8. Reposition belt idler for hydrostatic drive.
9. Reassemble belt guard.

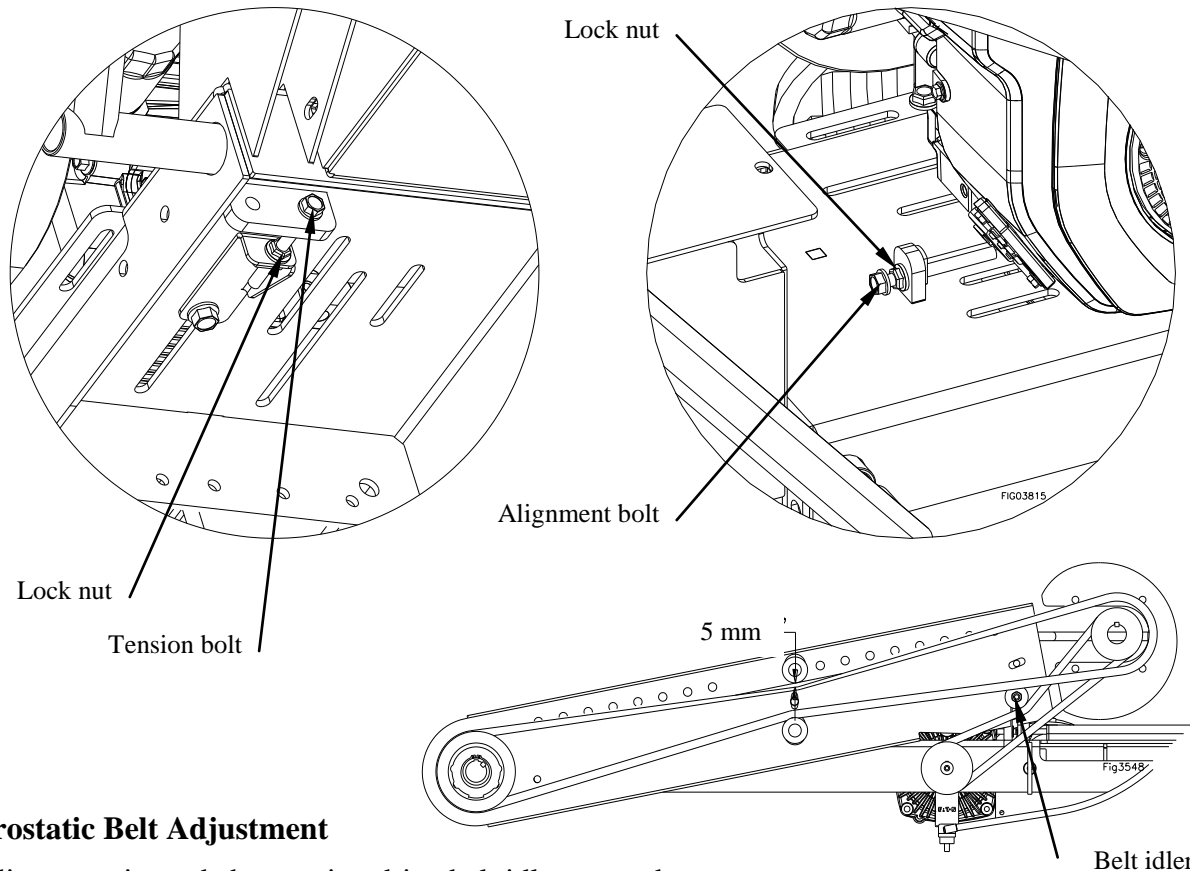

Hydrostatic Belt Adjustment

Adjustment is made by moving drive belt idler up or down.

▲ CAUTION: Over tightening this belt will damage the hydrostatic pulley.

Note: New belts require a "break-in" period of approximately 10 hours. Readjustment may be necessary after "break-in."

Note: Use only factory recommended belts. Contact your Dosko dealer.

Maintenance & Repair (cont'd)

2. Hydrostatic Drive

Neutral Adjustment

The drive itself contains no adjustments. The ground control lever, when in automatic neutral position, should not allow any forward or rearward creeping of the grinder (providing the grinder is on level ground – on unlevel ground, see brake control instructions).

- Neutral position is adjusted by removing the quick disconnect from the control arm, located on the bottom side of the transmission.
- Turn the "Quick Disconnect" socket one (1) complete turn in either forward or the reverse position to adjust transmission into neutral (more than one turn may be needed in some cases).

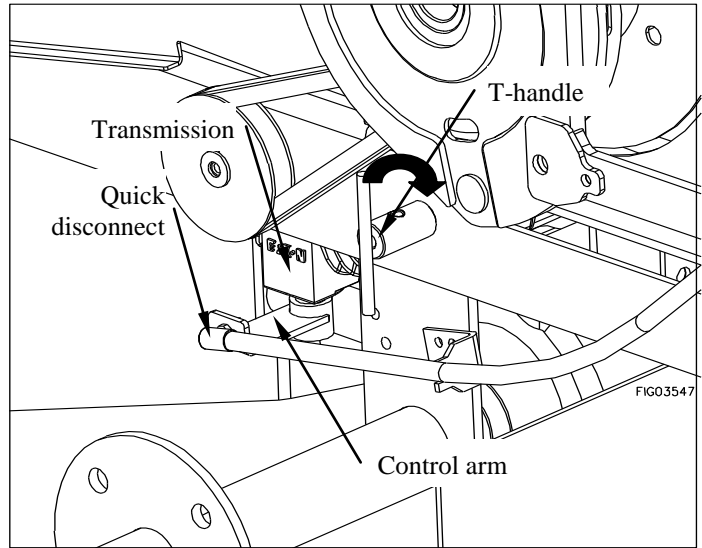

Disengagement Adjustment

When the engine is not running, the grinder cannot be moved; the hydrostatic drive is in the "locked" position.

- Turn T-handle clockwise to unlock the transmission.
- This will allow freewheeling / manual movement of the stump grinder.

3. Electric Clutch Engagement

The electric clutch needs no adjustments or lubrication.

⚠ CAUTION

1. Never engage clutch over 1,800 RPM (1/2 throttle). Any clutch engagement over 1,800 RPM can and will damage the clutch.
2. Make sure that there is a minimum of 12 volts to the clutch at all times. The torque arm on the clutch must move freely at all times from 3 mm up and down, and from side to side. You can visually inspect the torque arm through the square hold located in the backside of the belt guard.

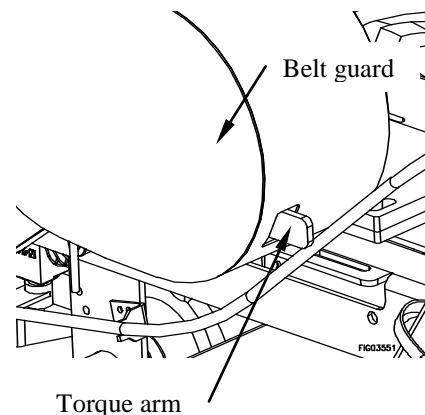

⚠ DANGER: Never transport the stump grinder with the clutch engaged or cutter wheel rotating.

Maintenance & Repair (cont'd)

4. Stop-Switch Adjustment

⚠ CAUTION:

Never attempt to alter, modify or override this switch.

If Stop-switch needs to be replaced or adjusted follow the below directions.

1. Loosen Hex Nut.
2. Turn the Linkage Bolt clockwise to lower or counter-clockwise to raise the point of interaction with Stop Switch. To set the proper interaction distance, lower the Linkage Bolt onto the Switch Button until you hear the switch "CLICK". Then raise the linkage bolt a 1/4 turn (clockwise).
3. Tighten Hex Nut.
4. Verify operability of operator presence switch before operating machine by releasing the operator presence bar next to the handle bar. You should hear a "CLICK", signifying that the Linkage Bolt has been adjusted properly.

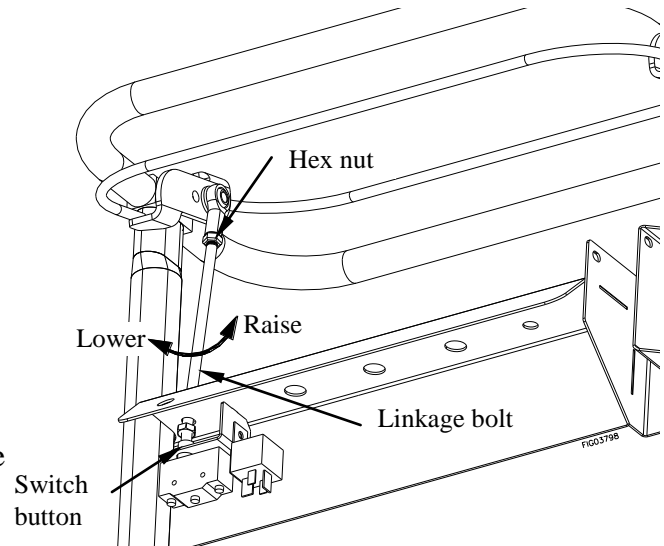

5. Setting & Sharpening Teeth

Among the most critical elements of the stump grinder is the cutting wheel. It is also the most subject to damage and wear. In the course of grinding stumps it not only makes contact with the wood, but also encounters numerous abrasives and objects in the stump's environment, such as dirt, stones, large rocks and buried scrap.

The loss and wear of cutting teeth can significantly impair the efficiency and performance of the stump grinder. Therefore, it is important to make frequent inspections of the condition of all the cutting teeth and to sharpen or replace any damaged or worn teeth. Sharpening the teeth before excessive wear will result in longer lasting teeth and better performance.

Setting Teeth

Installing pockets

1. Locate the straight teeth and pockets on your wheel.
2. Remove one set of straight teeth and pockets.
3. Clean this area with a wire brush.
4. Start with a counterbored pocket. Counterbored pockets have non-threaded big holes. They go on the right-hand side of the wheel as you face the wheel. Install two pocket bolts into the counterbored pocket holes.
5. Apply anti-seize onto the threaded position of the pocket bolt.
6. Slide the counterbored pocket and pocket bolts through the holes in the wheel from the right side and thread them into the threaded holes in the threaded pocket. Firm up the pocket bolts until pockets are firm on the wheel. Do not tighten then down yet.

Maintenance & Repair (cont'd)

7. Rotate the wheel until you come to the next set of straight teeth. Repeat steps 2 – 6.
8. Next, replace the angle pockets (angles occur away from the wheel).
9. Remove one set at a time or all old angle teeth and pockets at once. Clean the wheel with a wire brush.
10. Install your pocket bolt through the holes in the counterbored pocket. Apply anti-seize. Slide the pocket bolts through the holes in the wheel. Make sure the counterbored pocket is on the right hand side of the wheel. Insert the pocket bolts into the threaded pockets and tighten the pockets firmly onto the wheel. Repeat this step until all your standard angles pockets are installed.

Installing teeth

1. If all the counterbored pockets are on the right hand side of the wheel, your tooth will go into your pocket properly. If your pockets are mounted upside down, the teeth will have a tendency to spin freely or be sloppy in the pocket.
2. Install your teeth with the carbide facing down. The shoulder of the tooth will meet the flat detent of the pocket and the tooth will not rotate. Thread nut onto the top portion of the tooth. Hand tighten for now. Repeat until all teeth are installed.

Torque

1. Torque the pocket bolts to 245 – 325 Nm.
2. You will notice the slotted end of the pocket bolt is about 3 mm short of the end of the threaded pocket. This is okay. This area will fill with dirt and protect the extraction slot at the end of the pocket bolt. If you need the slot, clean out the packed dirt and use the slot to turn out the broken bolt.
3. To torque your tooth down, tighten the top lock nut to 15-21 Nm, until the tooth is firmly seated. Double check that the tooth is firmly seated. Do not over tighten. Over tightening the nut will stretch the threads and make it impossible to ever tighten again.
4. Once the pocket bolts, teeth and nuts are seated and torqued properly, cut a few stumps. Recheck bolts and nuts to make sure they are tight and secure. Recheck frequently for the first week of use and once a week thereafter.

When you dull or damage a cutting edge, loosen the top nut, tap the tooth down, rotate the tooth a third of a turn and tighten back up.

Sharpening Teeth

Dosko cutting teeth are tipped with heavy-duty carbide. Carbide retains its sharpness longer; cuts faster and smoother, and can withstand heat better. Though carbide is tremendously hard, it is also reasonably brittle.

Sharpening carbide-cutting teeth requires a special process. Contact your dealer or Dosko Customer Service @ 1-763-428-2237 for sharpening instructions.

Maintenance & Repair (cont'd)

6. Maintenance Schedule

⚠ CAUTION:

Before attempting any maintenance, be sure that the engine is shut off, the key, the positive battery cable, and both spark plugs are removed, and the engine is cool to the touch!

Item (What to check or action req'd)	Daily	Each Use	10 hours	20 hours	40 hours
Bearings, Shaft - Grease				X	
Belt Tension - Tension					X
Bolts - Tightness			X		
Engine – See manual					
Gasoline – Amount		X			
Safety Switches – Operation		X			
Warning Decals – Legible	X				
Tires, Flaps – Condition	X				
Wires, Cables – Condition		X			
Cutter Teeth - Sharpness		X			

IMPORTANT:

If a part needs replacement, only use parts that meet the manufacturer's specifications. Replacement parts that do not meet specifications may result in a safety hazard or poor operation of the grinder.

**Contact Dosko Customer Service at 1-763-428-2237
for any questions, problems, or parts orders.**

Specifications

	2961040	2961050
ENGINE OPTIONS		
Make	Honda	Kohler
Model	GX630RTXF2	CH730-0002
CC Rating	630 cc	721 cc
GENERAL		
Weight	500 lbs. (227 kg)	
Length	85" (218 cm)	
Height	56" (142 cm)	
Width	30" (76 cm)	
RPM Operating	3600 RPM	
Type of Fuel	Gasoline	
Starting	Electric	
Oil Sensor	Yes	
CUTTER WHEEL		
Diameter	14" (36 cm)	
Thickness	3/8" (.95 cm)	
Bearings (Dia.) (2)	1-3/16" (3 cm)	
Teeth Pockets	Reversible	
Teeth (8) (Carbide Tips)	Greenteeth®	
	1/2" dia. (1.27 cm)	
	1/4" thick (.635 cm)	
Disc RPM	3000 RPM	
Drive	Electromagnetic Clutch	
	2 Gates belts	
	2V-belts with Idler Bearing tensioners	
CUTTING CAPACITY		
Above Grade	24" (61 cm)	
Below Grade	18" (46 cm)	
Stump Diameter	No Limit	
GROUND TRAVEL		
Speed	0-3 MPH; Not towable	
Drive	Hydrostatic Drive	
	16-650 x 8" (480 x 20 cm)	
Brake	Disc Brake with Adjustable Brake pads	
NOISE AND VIBRATION DATA		
Sound Pressure	92 dBA	103 dBA
Sound Power	102 dBA	113 dBA
Hand-Arm Vibration	4.43 m/s ²	4.27 m/s ²
Standard Deviation	0.75 m/s ²	0.91 m/s ²

Summary of Important Safety Information

This section provides a summary of the various safety procedures and measures that have been presented throughout the manual. Keep this summary handy and refer to it to refresh your memory about how to safely use your grinder.

WARNING

Carefully read and make sure you understand the following safety information before using the grinder. Improper use or maintenance of the grinder can result in *serious injury or death* from *fire/explosion, carbon monoxide poisoning, lacerations, entanglement or burns*. Damage can also occur to windows, siding, vehicles, and bystanders from chips and debris which can become projectiles.

General

- **Read manual.** Read this Owner's Manual and the engine Owner's Manual completely before attempting to use and service the grinder. Serious injury or death can result if safety instructions are not followed.
- **Instruct operators.** The grinder owner or rental company must instruct all operators in safe grinder set-up and operation. Do not allow anyone to operate the grinder who has not read the Owner's Manual and been instructed on its safe use. Make sure Owner's manual is within the attached storage tube on the grinder.
- **Adults only.** Only trained adults should operate and service the grinder. Do not let children operate.
- **Under the influence.** Never operate, or let anyone else operate, the grinder while under the influence of alcohol, drugs, or medication.
- **Intended use.** Carefully read about and understand the intended use of this grinder. Do not use for other purposes, as unforeseen hazards or equipment damage may result.
- **Controls and safety labels.** Learn how to use the machine and its controls safely. Understand and follow all safety labels.
- **Weather.** Never use in foul, bad or questionable weather, which causes a slippery ground condition.

Prohibition Against Modifications

Never modify or alter the grinder in any way. Modifications can create serious safety hazards and will also void the warranty.

- **Fuel/exhaust system.** Never modify the exhaust system, fuel tanks, or fuel lines. Carbon monoxide poisoning, fire, or explosion could result.
- **Guards.** Do not operate grinder unless all guards and cover shields, which prevent access to moving parts and pinch points, are in place. Failure to guard the power transmission mechanisms *may result in serious injury or death*.

Safety – Before Use

Know how to operate

- **Review safety rules.** Before use of this grinder, review the "Rules for Safe Operation."
- **Know how to operate.** Be thoroughly familiar with all controls and with the proper use of the equipment. Know how to stop the grinder quickly if needed.
- **Utility marking.** Call 811 for utility marking 3 days before stump grinding. Trees can grow on top of and around underground wiring that was installed many years before a tree was planted.

Getting Ready

- **Flying debris.** Clear area of objects such as stones, toys, steel wire, etc. that could become caught in moving machine parts and ejected as a projectile.
- **Operate OUTSIDE only – dangerous carbon monoxide exhaust!** Grinders give off carbon monoxide exhaust, a poisonous gas that can kill. You CANNOT smell it, see it, or taste it. ONLY run grinder OUTDOORS and away from building air intakes. NEVER run grinder engine inside homes, garages, sheds, or other semi-enclosed spaces. These spaces can trap poisonous gases.
- **Cooling ventilation.** The grinder needs adequate, unobstructed flow of air to allow for proper cooling of engine and grinder head. Do not allow debris to accumulate and block airflow.

Summary of Important Safety Information (cont'd)

- **Transporting.** During transporting, take precautions to make sure stump grinder will not tip over and cause a fuel leak hazard.
- **Hot exhaust - fires.** Exhaust from engine can be extremely hot and cause fire. Position muffler at least 7 feet from combustible objects during operation.
- **Fire extinguisher.** Keep a fire extinguisher rated "ABC" by the National Fire Protection Association nearby is always recommended when using gasoline-operated machinery. Keep it properly charged and be familiar with its use.

Personal protective equipment

- **Hearing protection.** The use of earplugs or other hearing protection device is recommended for those in close proximity to the grinder while it is operating.
- **Eye protection.** Wear ANSI approved eye protection when operating the grinder.
- **Face protection.** A helmet with a full-face visor or mesh visor with protective glasses is recommended.
- **Loose / dangling.** Loose or dangling apparel, jewelry or hair can become entangled in moving parts. Never wear jewelry or loose-fitting clothing when operating the grinder.
- **Long pants.** Wear long, heavy-duty pants to protect legs from ejected materials.

Gasoline Safety

Gasoline is highly flammable and explosive. You can be burned or seriously injured when handling fuel. Use extreme care when handling gasoline:

- **Fuel outdoors.** Fill fuel tank outdoors – never indoors. Gasoline vapors can ignite if they collect inside an enclosure. Explosion can result.
- **Use approved container.** Never pump fuel directly into engine at gas station. Static charge can build and ignite fuel. Use an UL approved fuel container to transfer gas to the engine.
- **Running / hot engine.** A running engine is hot enough to ignite fuel. Never add fuel or remove gas cap if engine is running or still hot. Stop the engine and allow to cool at least two minutes before adding fuel.
- **Heat / flames / sparks.** Keep sources of heat, flame, or sparks away while adding fuel.
- **Don't fill to the top** DO NOT overfill the gas tank. Allow at least 1" of empty space below the fill neck to allow for fuel expansion and operation on slopes.
- **Don't fill to the top.** Do not fill the gas tank to the top. Gasoline may spill when operating on a slope.
- **Replace cap.** Replace gas cap securely before starting engine.
- **Spills.** Clean up fuel spills immediately. Move grinder away from spilled fuel on the ground. Wipe fuel off engine and wait 5 minutes for excess fuel to evaporate before starting engine. Gas soaked rags should be disposed of properly.
- **On skin / clothes.** If gasoline is spilled on your skin or clothes, change clothes and wash skin immediately.
- **Inspect fuel system.** Check fuel system on a regular basis. Look for signs of leaks, deterioration, chafed or spongy fuel hose, loose or missing fuel hose clamps, damaged fuel tank, or a defective fuel shut-off valve. Do not start grinder until needed repairs have been completed.
- **Gasoline storage.** Store gasoline in a cool, dry place in an UL-approved, tightly sealed container away from children.

Safety – During Use

- **Safety equipment / controls.** Always operate the grinder with all safety covers, guards, and barriers in place and in good working order, and all controls properly adjusted for safe operation.
- **Controls.** Stay in the OPERATOR POSITION while actuating controls.
- **Know how to stop.** Know how to stop the grinder quickly if needed by releasing the operator presence bar. If this does not work, do the following in order until unit is stopped. 1. Push the stop button on the control panel. 2. Use on/off switch on engine (or ignition switch on electric start models). 3. Engage full choke by flooding the engine.
- **"Kickback".** Machine can experience significant "kickback" when operating or first coming into contact with the stump.
- **Slipping/Falling.** Operating in wet or icy conditions could lead to losing your footing and slipping or falling.
- **Damaged.** Do not operate the grinder with damaged, missing, incorrectly adjusted, or broken parts.
- **Check for gas leak before starting.** After opening gasoline valve, smell for gas before starting engine. If you smell gas, DO NOT start engine. DO NOT light a match. DO NOT flip on an electrical switch. Exit area immediately and call fire department.
- **Carbon monoxide exhaust.** The running engine gives off carbon monoxide, a poisonous gas that can kill you. You CANNOT smell it, see it, or taste it. If you start to feel sick, dizzy, or weak while using the grinder, shut off the engine and get to fresh air RIGHT AWAY. See a doctor. You may have carbon monoxide poisoning.

Summary of Important Safety Information (cont'd)

- **Other exhaust dangers.** This product contains or emits chemicals known to the State of California to cause cancer, birth defects or other reproductive harm. Avoid inhalation of exhaust.
- **Smoking/sparks.** Never smoke near the running grinder, and never operate near sources of sparks or flames.
- **Hot muffler.** Never touch hot muffler or hot exhaust manifold. Exhaust and engine parts can be very hot and will burn you.
- **Machine's moving parts.** Keep hands, feet, and apparel away from drive belts, cutter wheel, and other moving parts. Never remove any drive belt or guard while the unit is operating. Contact with belt or rotating teeth will cause personal injury.
- **Refueling.** DO NOT refuel the engine until it has cooled at least two minutes.
- **Malfunction during operation.** Always shut the machine off if any unusual noise or vibration occurs.
- **Vibration.** Overexposure to machine vibration on a daily basis may lead to circulatory or nerve damage.
- **Adjusting / repairing.** Always turn off grinder and remove spark plug or spark plug wire before working on the grinder to prevent accidental starting. Disconnect battery.

Safety – After use

- **Cool engine before storing.** Let engine cool for at least five minutes before storing. A hot engine can be a fire hazard.
- **Shut off fuel supply.** Make sure gasoline shut-off valve is in the OFF position. (Honda GX390 only)
- **Prevent accidental starting.** When grinder is not in use, remove key from starter (electric start engines) and secure in a safe location, or remove spark plug and disconnect positive battery terminal from battery in order to ensure that grinder cannot be started in a storage location or by untrained persons.
- **Storage location.** Store the grinder in a dry location away from sources of heat, open flames, sparks or pilot lights – such as water heaters, space heaters, furnaces, clothes dryers, or other gas appliances – EVEN IF the grinder's gas tank is empty. Residual gasoline could ignite.
- **Exercise regularly.** Exercise grinder every four weeks to dry out moisture that accumulates in the windings. If grinder cannot be exercised on a regular basis, prepare grinder for long-term storage.

Safety - Inspection/Maintenance

Inspect and maintain your grinder on a regular basis and repair as needed to keep it in safe working condition:

- **Turn off grinder.** Always turn off grinder and remove spark plug or spark plug wire before working on the engine or grinder to prevent accidental starting. Disconnect battery
- **Replace guards / shields.** Make sure all guards and shields are replaced after servicing the grinder.
- **Burns.** Do not touch hot muffler. Muffler will be hot even if unit is stopped. Allow unit to cool before servicing.
- **Replacement parts.** If a part needs replacement, only use parts that meet the manufacturer's specifications. Replacement parts that do not meet specifications may result in a safety hazard or poor operation of the grinder and will void the warranty.

Special Safety Information on Static Electricity

Static electricity and filling gasoline:

Static electricity can initiate from ungrounded gasoline tanks or containers, from flowing gasoline, and from persons carrying a static electric charge

Static electricity on numerous occasions has explosively ignited gasoline vapors that were present during fueling processes, resulting in serious burns to nearby persons. To avoid static electricity while fueling, certain steps must be followed before and during the fueling process in order to minimize and safely dissipate static charge build-up.

Filling Portable Containers at Service Stations:

Use a portable container to fill grinder tank. Never fill the grinder's gas tank directly from the service station's fuel dispenser pump – the grinder's tank is not grounded and the high velocity flow of gasoline from a fuel pump can cause static electric build-up. Use an approved portable container to transfer gasoline to the grinder's tank.

- ***Use a portable container made of metal or conductive plastic.*** It will dissipate charge to ground more readily.
- ***Fill container on the ground.*** Never fill the portable gas container while it is sitting inside a vehicle, trailer, trunk, or pick-up truck bed. ALWAYS place container on the ground to be filled.
- ***Touch a grounded metal object before starting.*** Always dissipate static charge from your body before beginning the fueling process by touching a grounded metal object at a safe distance away from fuel sources.
- ***Keep nozzle in contact with container.*** Keep fuel dispenser nozzle in contact with the portable container at all times while filling at a service station. Do not use the nozzle lock-open device on the dispenser hose.

About static electricity and fueling

Many common objects can accumulate and retain a static electric charge. Objects made of non-conductive materials (e.g. plastics) easily accumulate and retain static electric charge, as can objects made of conductive material (e.g. metal, water) if they are not electrically grounded. The static electric charge on an object, such as a human body or plastic fuel tank/container, can reach as high as several thousand volts!

A static electric spark can be generated if the static electric charge stored on an object "jumps" to another, less charged object. Such a spark can ignite invisible gasoline vapors that are present during fueling situations.

Typical sources of static electric hazards during fueling

The following objects can accumulate a static electric charge and cause an ignition spark in typical fueling situations:

- **Ungrounded tanks/containers.** Any ungrounded fuel tank or container can accumulate a static electric charge as a result of contact with other objects or friction during transportation. This static electricity can discharge as a spark to the grounded gasoline dispenser nozzle, as the nozzle is first brought close to the tank/container at the beginning of the fueling process.
- **Flowing gasoline.** Most people are not aware that gasoline accumulates static electric charge while flowing through a hose or pipe. This charge then transfers to and accumulates in the gas tank or container that is being filled. The total amount of charge accumulation depends on the amount of gas pumped into the container, the speed with which it is pumped, and whether or not the tank/container is grounded. If sufficient static electric charge accumulates in the fuel tank or container during the fueling process, the tank/container may discharge a spark to the grounded gasoline dispenser nozzle.
- **Persons.** A person dispensing the gasoline can carry a static electric charge on their body, typically resulting from contact with their car seat or electronics. The static electricity can discharge as a spark between that person's hand and either the grounded dispenser nozzle or the fuel tank opening.

M2961040BOE Exploded View – Rev C.1

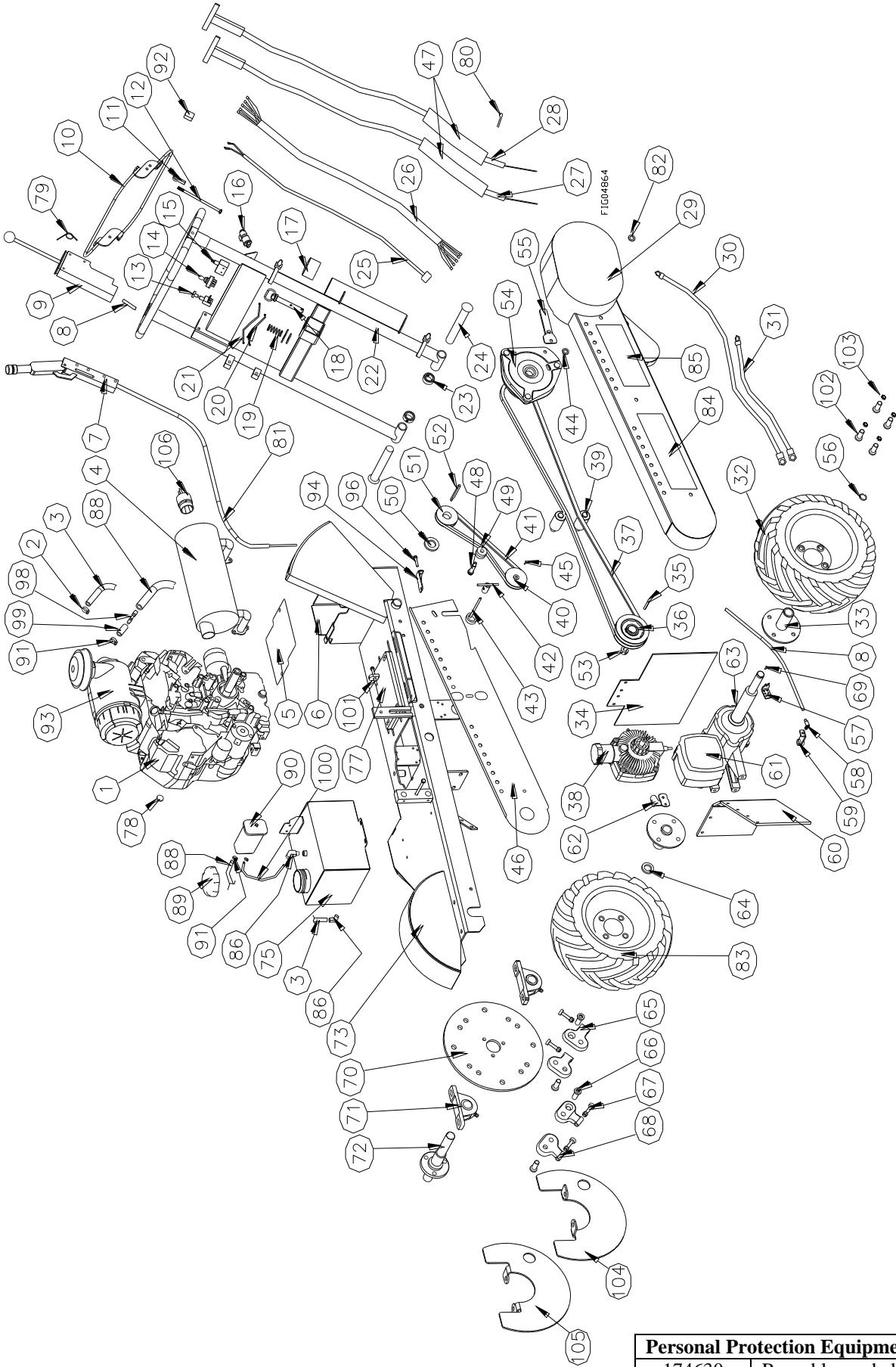

Personal Protection Equipment (not shown):		
174630	Reusable corded earplugs	1
174653	Face shield	1
174690	Safety eyewear	1
8467	Safety gloves	1

M2961040BOE Parts List – Rev C.1

Item	Part #	Description	Qty	Model	Item	Part #	Description	Qty	Model
1	783896	GX630 Honda engine	1	2961040	47	785391	3/8" heat sleeve	18"	All
	784704	25hp Kohler engine		2961050	48	82358	1/2" shoulder bolt	1	All
	784719	Shield			49	784672	Drive idler bearing	2	All
2	777834	1/4" Hose clamp	4	All	50	784628	Engine pulley spacer	1	2961050
3	777345	1/4" Fuel hose	42"	All	51	784178	3", 1-1/8" sheave	1	All
4	783395	Muffler	1	2961040	52	784794	1/4" x 1/4" x 3.75"key	1	2961040
	784712	Muffler	1	2961050		82359		2961050	
	784058	Spark arrestor							
	784713	Muffler guard							
5	789467	Battery box top	1	All	53	783565	1-3/16 bushing	1	All
6	789468	Battery box	1	All	54	784663	Electric clutch	1	All
7	783547	Brake lever assembly	1	All	55	789473	Clutch bracket	1	All
8	784667	Control cable	1	All	56	82349	1" ring clip	2	All
9	784666	Direction control lever	1	All	57	784668	Cable locking bracket	1	All
10	783493	Operator presence handle bar	1	All	58	784669	Cable pivot qck discon.	1	All
11	782399	Ball joint rod	1	All	59	789474	Control actuator (arm)	1	All
12	82392	5/16"-24 x 7-1/2" bolt	1	All	60	783551	Chute flap	1	All
13	786073	On/off switch, grinder	1	2961040	61	784664	Gasket	1	All
	783546			2961050					
14	30194	Ignition switch	1	2961040	62	789475	Brake lever bracket	1	All
	784674	Key switch assembly		2961050					
15	783545	Microswitch	1	All	63	784173	Peerless differential	1	All
	783769	Microswitch bracket							
16	784670	On/off switch, clutch	1	All	64	784631	Wheel spacer	1	All
17	783815	Black vinyl cap	1	All	65	784165	500 series straight pckt	4	All
18	783774	4" Hitch pin	1	All	66	783555	Pocket bolt	8	All
19	783539	2" Spring	1	All	67	783557	500 series tooth	8	All
20	783284	6" Lead wire, green	1	All	68	783554	500 series angled pocket	4	All
21	783285	8" Lead wire, green	1	2961050	69	82343	1/4" x 1-1/8" keyway	2	All
22	789469	Handle	1	All	70	787450	Cutter wheel, 14"	1	All
23	783538	Lock collar	2	All	71	783556	Pillow block bearing	2	All
24	37878	1" x 6" clevis pin	2	All	72	785079	Cutter shaft w/ studs	1	All
25	784671	Wire harness, clutch	1	2961050	73	789477	Frame	1	All
26	790000	Wire harness	1	2961040	75	785581	Fuel tank	1	All
	784708			2961050	77	789478	Engine riser	1	2961040
	784899								
27	784207	Throttle cable	1	All	78	784718	Plastic plug, ignition	1	2961050
28	784208	Choke cable	1	All	79	783924	Spring	1	All
29	789470	Outer belt guard	1	All	80	784714	1/4" cable loop clamp	2	2961050
30	32839	43" Battery cable (red)	1	All	81	785756	Brake cable	1	All
31	777108	24" Battery cable (blk)	1	All	82	35198	Grommet	1	All
32	784148	Tire and rim (left)	1	All	83	785509	Tire and rim (right)	1	All
33	789471	Hub	2	All	84	783543	Dosko decal	1	All
34	783550	End flap	1	All	85	783544	Stump grinder decal	1	All
35	82143	1/4" x 1-3/4" keyway	1	All	86	783212	1/4" x 1/4" HB elbow	2	All
36	785179	Cutter sheave	1	All	88	785755	3/8" fuel line	72"	2961040
37	784181	AX90 Belt, clutch	2	All		777345	1/4" fuel line	44"	2961050
38	784171	Eaton transmission	1	All	89	784769	Sealed fuel cap	1	All
39	783552	Idler bearing	2	All	90	781922	Carbon canister	1	All
40	784793	3", 11/16" sheave	1	All	91	30746	3/8" hose clamp	2	2961040
41	784182	A2340 belt transmission	1	All	92	780091	12V, 80 amp relay	1	2961040
42	784141	Neutral t-handle	1	All	93	785411	Air cleaner	1	2961040
43	784143	Cam lever	1	All	94	779570	Belt tensioner	1	All
44	784630	Engine shaft cap	1	All	96	82304	5/16"-18 x 3" bolt	1	All
45	82342	1/8" x 1/2" keyway	1	All	98	785767	1/4" x 3/16" hose mender	1	2961050
46	789472	Inner belt guard	1	All	99	785337	4.5mm fuel line	2"	2961050
					100	777345	1/4" fuel line	13"	All
					101	82463	5/16"-18 x 4-1/2" bolt	1	All
					102	82033	1/2"-13 x 1-1/2" bolt	8	All
					103	82037	1/2"-13 lock nut	8	All
					104	789488	Right Cutter Guard	1	2961040
					105	789487	Left Cutter Guard	1	2961040
					106	781341	Spark Arrestor	1	2961040

Wiring Diagram – Item # 2961040 (Honda)

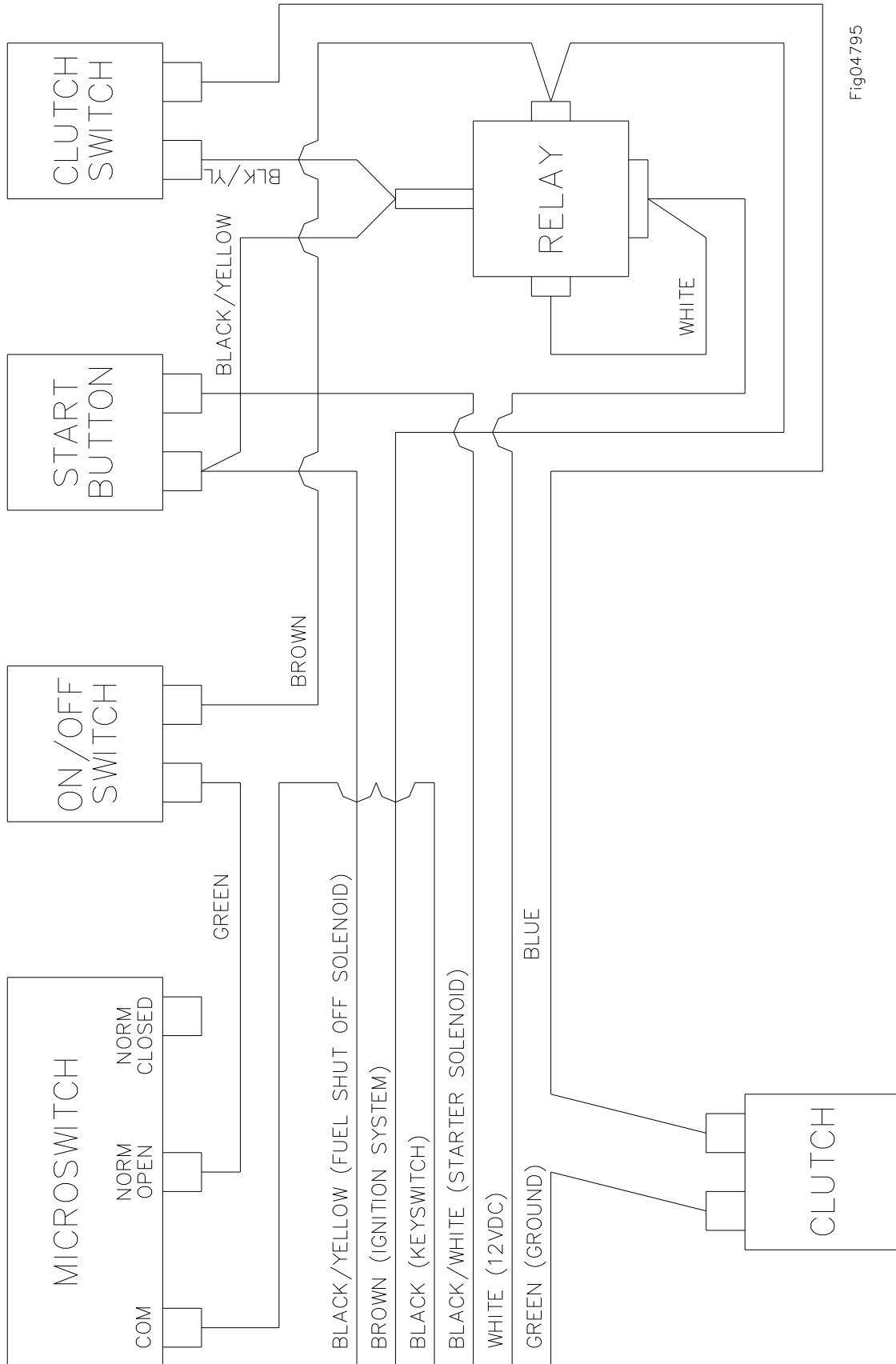

Fig04795

Wiring Diagram – Item # 2961050 (Kohler)

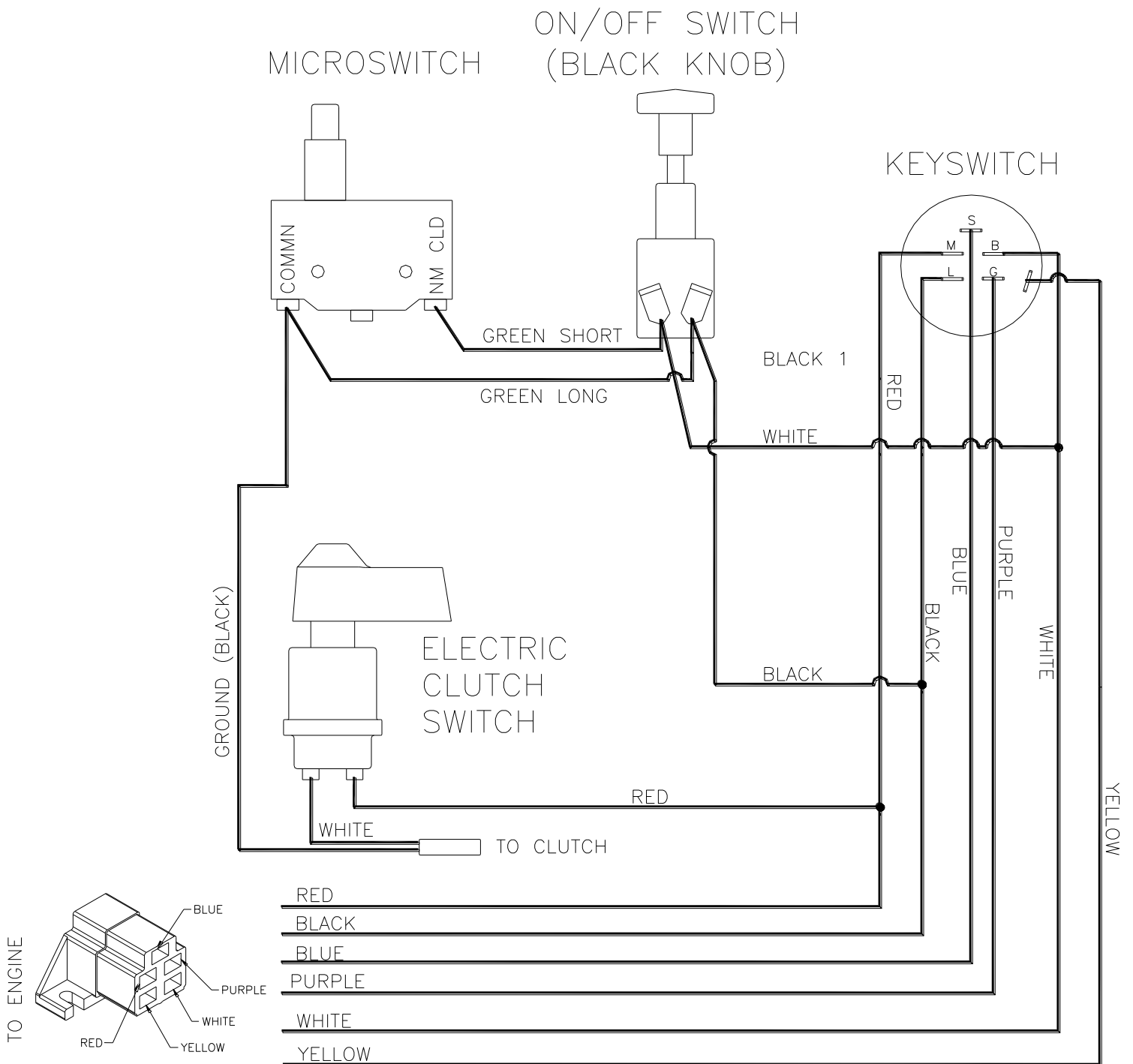

FIG03754

Limited Warranty Policy

August 2010

This warranty is limited to Dosko units distributed by Great Northern Equipment Distributing, Inc. 20195 South Diamond Lake Road, Rogers, MN and sold by dealers or distributors authorized to sell that product. The following warranty applies to Dosko units purchased at retail or placed into rental service on or after August 1st 2010.

Dosko warrants each Dosko unit to be free from defect in factory materials and workmanship for a period of 90 days from date of purchase or first rental. See limitations and time parameters stated below.

DOSKO SHALL NOT BE LIABLE FOR ANY IMPLIED WARRANTIES INCLUDING THE IMPLIED WARRANTIES OR MERCHANTABILITY AND FITNESS ON ITS PRODUCTS AFTER THE 90-DAY PERIOD.

DOSKO WARRANTY ON ANY OF ITS PRODUCTS SHALL BE VOID IF THE PRODUCT HAS BEEN MODIFIED BY THE ADDITION OF PARTS OR THE DELETION OF PARTS. IN THIS EVENT, TO THE EXTENT PERMITTED BY FEDERAL, STATE OR LOCAL LAWS, DOSKO SHALL BE UNDER NO LIABILITY WHATSOEVER IN RESPECT TO ANY LOSS, DAMAGE, INJURY, OR EXPENSE ARISING FROM ANY DEFECTS IN ANY DOSKO PRODUCTS.

The warranty period, as explained in the Warranty Policy, is for 90 days from the original date of sale. The fact that our product is repaired, or parts are replaced during the original 90-day period, does not extend the expiration date of the original warranty due to any loss of time resulting from failures. This warranty shall not apply to any Dosko product which has been modified, repaired, or altered in such a manner as to affect its stability, performance or operation, nor which has been subjected to misuse, abuse, negligence or accident.

The owner is responsible for all regular maintenance as explained in the operator's manual. Neglect in regular maintenance or failure to replace normal wear items such as knives, bed knife, lubrication, oils, filters, belts, bearings, etc. may void warranty.

Your authorized Dosko dealer will repair or replace, any parts that are found to be defective within the warranty period. **ALL WARRANTIES MUST BE PRE-APPROVED** through Dosko warranty department prior to any work being done. Failure to do so will void warranty and reimbursement will not be permitted. Proof of purchase date must be provided.

In order to register for the warranty on your new Dosko unit, the dealer or rental owner should fill out and return to Dosko the enclosed warranty registration cards within ten (10) days after your purchase.

"No Warranty on Purchased Wear Parts"

Purchased wear parts (example: tires, battery, engine, belts, spark plugs, etc.) are not warranted by Dosko.

Description of Limited Warranty of Major Component Parts

Major component failures will be handled according to Manufacturer's warranty statement. Problems and defects in the engine should be referred to your authorized engine repair dealer. Other major component failures will be handled according to appropriate manufacturer's warranty statement otherwise 90 day warranty applies.

Limited Warranty of Frames/Fabrication

Dosko warrants any steel frame, tow bar, handlebar or chute for a period of two (2) years from original date of purchase to be free from defects.

DOSKO

Great Northern Equipment Distributing Inc.
20195 S. Diamond Lake Rd, Ste 100
Rogers, MN 55374
Made in USA

Authorized Representative
QNET BV
Hommerterweg 286
6436 AM Amstenrade
The Netherlands