

COMBI 250/1000 VA

SAWING MACHINE



MODEL NUMBER: 1188174
SERIAL NUMBER: 0000704062
WEIGHT LBS: 132



1188174#0000704062

OPERATING, MAINTENANCE, SPARE PARTS MANUAL

IMER U.S.A. Inc.

Toll Free: 800.275.5463

www.imerusa.com

info@imerusa.com

IMER WEST

3654, Enterprise Avenue
Hayward, CA 94545
Ph. 510.670.7970
Fax 510.783.4255

IMER EAST

221 Westhampton Place
Capitol Heights, MD 20743
Ph. 301.336.3700
Fax 301.336.6667

2007/09 - R02

Cod. 3227118

Dear Customer,

Congratulations on your choice of purchase: IMER saws are the result of years of experience and are equipped with all the latest technical innovations.

 - **WORKING IN SAFETY**

To work in complete safety, read the following instructions carefully before using the machine.

To work in complete safety, read the following instructions carefully before using the machine.

This OPERATION AND MAINTENANCE manual must be kept on site by the person in charge, e.g. the SITE FOREMAN, and must always be available for consultation.

The manual is to be considered integral part of the machine and must be kept for future reference (EN 12100/2) until the machine is disposed of. If the manual is damaged or lost, a replacement may be requested from the manufacturer.

The manual contains important information regarding site preparation, machine use, maintenance procedures, and requests for spare parts. Nevertheless, the installer and the operator must both have adequate experience and knowledge of the machine prior to use.

To guarantee complete safety of the operator, safe operation and long life of equipment, follow the instructions in this manual carefully, and observe all safety standards currently in force for the prevention of accidents at work (use of safety footwear and suitable clothing, helmets, gloves, goggles etc.).

 - Make sure that all signs are legible.

 - It is strictly forbidden to carry out any form of modification to the steel structure or working parts of the machine.

IMER INTERNATIONAL declines all responsibility for failure to comply with laws and standards governing the use of this equipment, in particular; improper use, defective power supply, lack of maintenance, unauthorised modifications, and partial or total failure to observe the instructions contained in this manual.

IMER INTERNATIONAL reserves the right to modify features of the saw and contents of this manual, without the obligation to update previous machines and/or manuals.

1. TECHNICAL DATA

Technical data are stated in table 1 and electrical specifications in table 2.

Table 1 - TECHNICAL DATA	
Model	Combi 250/1000 VA
Max. blade diameter	10 inches
Diamond Blade hole diameter	5/8 inches
Single phase 115V/60Hz motor power	1.1 kW
Max. blade rotation speed	3400 rpm
Cutting table dimensions	1115x500 mm
Length of 90° cuts (thickness= 10mm)	950 mm
Length of cuts from above	1000 mm
Maximum cut depth with single stroke	66 mm
Maximum cut depth with two stroke	105 mm
Water pump flow rate	13 l/min
Water tank capacity	40 L
Machine dimensions	1420x636x619
Packed machine dimensions	1455x670x653 mm
Weight with packaging	65 kg

Table 2	
Feature	Motor (115V/60Hz)
Power (kW)	1.1
Rated voltage (V)	115
Frequency (Hz)	60
Absorbed current	14.4
Number of poles	2
rpm	3400
Service type	S6 40%
Insulation category	F
Protection category	IP55
Capacitor (µF)	110 (Ø 50x120)

2. DESIGN STANDARDS

Combi 250/1000 VA saws have been designed and manufactured according to the following standards: EN 12100-1-2; EN 60204-1; EN 12418.

3. SOUND PRESSURE LEVEL AND VIBRATIONS

Table 3 shows the sound pressure level measured loadless at the operator's ear (L_{pa}) and of the vibrations transmitted during operation.

Table 3			
Sawing machine	Type of motor	L_{pa}	A_{ms}
Combi 250/1000 VA	Electric	86 dB	2.57 m/s ²

4. GENERAL SAW DESCRIPTION

4.1 General description

The Combi 250/1000 VA is a saw comprising the following main sub-groups:

- cutter head (ref.A, fig.1)
- runner guide and arms (ref.B, fig.1)
- cutting tables and heads (ref.C, fig.1)
- water collection tank (ref.D, fig.1)
- frame (ref.E, fig.1)

The cutting head is mounted on a reinforced aluminium profile and is equipped with horizontal and vertical movement facilities. The aluminium profile is hinged onto die-cast arms (ref.F, fig.1) and the entire unit can rotate through 45° (fig.2) by means of the relative handwheels (ref. G, fig.2).

The machine is supported by a special metallic frame. There is a shock-proof plastic tank between the machine and the frame. The water immersion pump is mounted below the cutting surfaces on a special bracket and supplies a water distributor inside the blade guard for cooling the cutting blade during operation.

The high resistance plastic handle (ref.H, fig.2), is equipped with the main ON-OFF switch on the operator side to facilitate saw activation and shutdown. The raised position of the red OFF button on the handle is designed to facilitate shutdown of the machine in the event of an emergency. The motor capacitor is located in a protected position inside the handle.

The saw is fitted with a guard to guarantee optimal safety during operation and to protect the user during cutting cycles.

A valve is mounted above the blade guard to adjust the flow rate of water delivered to the cutting blade.

4.2 Processable materials

This saw has been designed for cutting the following materials: ceramic tiles, masonry and stone in general with maximum dimensions compatible with the length, cutting depth and dimensions of the surfaces specified in table 1.

Maximum weight of processable materials: 25 kg.

4.3 Unsuitable material

Materials unsuitable for this machine are all those not specified in paragraph 4.2.

In any event, before using the saw with materials other than as specified by the manufacturer for this saw model, contact IMER INTERNATIONAL S.p.A.

 - Use of this machine with workpieces outside the specified dimensions is strictly prohibited and constitutes a hazard for the operator.

5. OPERATION SAFETY

 - Before using the saw, ensure that all protection devices are fitted.

 - Never use the saw in environments subject to the risk of explosions or fire.

The saw is not fitted with specific lighting and therefore the workplace must be sufficiently lit for this purpose (min. 300 lux).

The power lines must be laid to prevent any possible damage. Ensure that the electrical connection is protected against the risk of water penetration in connectors. Use exclusively connectors and couplings equipped with water spray protection.

Never use inadequate or makeshift electrical lines or cables without earthing; if in doubt consult a specialised technician.

Repairs to the electrical circuit must be performed exclusively by specialised personnel. Disconnect the machine from the power supply before performing maintenance or repairs.

6. GENERAL SAFETY WARNINGS

Note that this machine has been designed to ensure optimal performance and maximum safety; however the operator must also guarantee this level of safety by paying special attention to the machine throughout all work phases.

1. Ensure that an efficient earthing system is installed.
2. Work only with all protection devices fitted correctly and in efficient working order.
3. Keep the machine clean: general cleaning (and the work surfaces in particular) represents an important safety factor.
4. Always stop the machine and disconnect from the power supply before cleaning or removing any protection device (for maintenance or disassembly purposes). If water jets are used for cleaning, never point jets directly at the power supply unit or electric motor.
5. Remove rings, watches, bracelets or ties before using the machine; these elements constitute a serious hazard to the operator. Also ensure that sleeves are tight around the wrists, hair is tied back and robust footwear is used.
6. Never cut workpieces that have dimensions or weight that are not suited to machine capacity as specified by the manufacturer (see point 4.2)
7. Always use personal protection devices such as safety goggles, suitably sized gloves, ear muffs or plugs and hair caps when necessary.
8. Use original diamond blades as recommended by the manufacturer to ensure optimal performance of the machine.
9. Always keep hands well away from the working zone while the machine is running; before removing workpieces from the blade area, always press the stop pushbutton to shut down rotation.
10. The Instructions in this manual are aimed at machine users (operators, maintenance engineers).
11. Never use diamond blades that are chipped or deformed.
12. Never use blades over the rotation speed specified by the manufacturer.
13. Use exclusively water-cooled continuous rim blades suited to the material to be cut.
14. Never dry cut material or cut when cooling water levels are low.

7. SAFETY DEVICES

The Combi 250/1000 VA has been constructed taking into account current harmonised European safety standards.

According to machine directive 98/37/EEC all safety devices have been installed with the aim of safeguarding the operator.

7.1 Guards and safety devices

The machine is equipped with fixed guards, secured by means of screws and protections that prevent access to moving or dangerous parts.

All fixed guards, covers, shields fixed by means of screws have been envisaged to protect the operator (maintenance engineers, technicians and others) from possible accidents caused by electrical discharge or moving mechanical parts.

Therefore use of the machine with guards removed or modified in any way is strictly prohibited.

 - Before performing maintenance or repairs to the machine, turn it off via the main switch and disconnect from the power supply to prevent inadvertent start-up and isolate all machine electrical circuits.

8. MACHINE INSTALLATION

8.1 Set up

Remove the machine packing.

The machine can already be used, leaving the legs folded, resting its frame on a sufficiently even surface at least as big as the tank.

Frame assembly:

1. remove the machine and tank from the folded frame.
2. remove the safety pins from the frame and open the legs.
3. put the safety pins back in the holes provided locking the legs in the open position.
4. reposition the machine and tank on the frame.

 - Make sure that the frame is positioned on a flat and even surface, capable of bearing the weight of the machine. The maximum permissible gradient in all directions is 6°.

8.2 Handling

The Combi 250/1000 VA sawing machine weighs 57 Kg and can be moved using the side handles on the tank (ref. I, fig. 1). For short distances use the wheels fitted on the frame. For longer distances, before moving the machine, close the frame reversing the sequence of the operations described in point 8.1.

Every time the machine is moved, make sure the head is locked tightening the knobs (ref. L, fig. 1).

 - Always empty the tank before moving the machine.

 - Always disconnect the power plug before moving the machine.

8.3 Additional table assembly (optional kit code 1188176)

The additional table can be positioned on the right or left side of the machine or on both sides at the same time.

Firstly insert the props (two for each table) in the grooves provided on the chosen side.

At this point you can install the additional table, which is supplied with the side supports already assembled. Insert these supports completely in the special housings machined in the machine sides. Then lower the additional table until it is on level with the machine table (fig. 6).

 - The use of additional tables without props can cause damage to them.

9. ELECTRICAL CONNECTION

 - Ensure that voltage corresponds to machine dataplate specifications.

The power supply line must be equipped with current overload protection (e.g. thermal cutout) and protection against indirect contact (e.g. residual current circuit breaker).

Connect the machine to an efficient earthing system.

The size of the power cable wires must be based on operating current and length of the power line to prevent excessive voltage drops (table 4).

Cable length (m)	V 115 I= 14,4 A	0 + 12	13 + 20	21 + 32
Cable (mm ²)		1.5	2.5	4

Connect the saw plug to the mains and tighten the mechanical retainer ring with IP67 protection rating.

The saw is now ready for operation.

10. MACHINE USE

10.1 Operation

The correct side for the operator is shown in fig.4 ref.X.
Fill the water tank to the maximum level (approx. 40 litres).
Connect the machine to the power mains and start as described in paragraph 10.
Open the valve (ref.N, fig.1) and ensure sufficient flow of cooling water to the diamond blade.

10.2 Cutting

Rest the material to be cut on the cutting table against the stopper. Define the required inclination using the goniometer. To adjust the cutting head height, loosen the handwheel (ref.O, fig.3), position the head at the required height, then fully tighten the handwheel. Make sure that handwheels for sloped cutting (ref.G, fig.2) are firmly tightened. Start the sawing machine as described in paragraph 10. To proceed with cutting, press the piece to be cut on the table with your hand and move the cutter head gripping the handle and drawing it towards you. If the feed speed is too fast in relation to the thickness and hardness of the material the blade might stop turning. In this case, release the disk as quickly as possible moving the cutter head away from you until the disk recovers its nominal rotation speed. Resume cutting, adjusting the feed speed according to the characteristics of the material.

10.3 Angled cuts

Loosen the handwheels (ref.G, fig.2), set the cutting head at the required angle, retighten the handwheels, and proceed as described in the point above.

 - Ensure that the tank is kept full during all work phases and in the event of prolonged work intervals replace water regularly and remove all processing residue.

10.4 Laser pointer

The machine is fitted with a laser pointer that reproduces the cutting line on the piece being machined. The track of light indicates the trajectory of the diamond disk during the feed motion. Making the required cutting profile coincide with the laser profile, it is possible to ensure the highest accuracy of the operation.

Cuts at right angle with one side of the piece being machined do not require tracing beforehand: in fact it will suffice to make sure that the side of reference is in contact with the stopper on the resting surface. Likewise, using the goniometer, cutting at predefined inclinations is possible. The laser light will indicate the actual position of the cut.

The laser pointer is activated when the machine is connected to the electric mains.

The pointer is aligned with the disk and must not be moved from its initial position.

 - The pointer used emits a low power laser light, but it is in any case advisable to avoid looking directly at the emitter itself.

11. MAINTENANCE

11.1 Premise

Routine maintenance operations can also be performed by non-specialised personnel provided that all safety standards specified in the relative sections of this manual are observed at all times.

11.2 Machine cleaning

The machine should be cleaned exclusively when it is stationary.

 - All power switches must be set to "0" and plugs must be disconnected from the mains.

1. Never use compressed air; this could cause infiltration of dust or residue in enclosed parts.
2. Ensure that the cooling water nozzles are not obstructed.
3. Above all the cooling water in the tank must be changed every day.
4. Do not use detergents or lubricants.

11.3 Waste disposal

As regards disposal of processing waste observe all current legislation in the country of use.

11.4 Repairs

Repairs to the electrical installation must be performed exclusively by specialised personnel. Use exclusively original IMER spare parts; modifications to parts are strictly prohibited. The special design of the Combi

250/1000 VA ensures that no other maintenance other than as specified above is required.

Ensure that the contacts of the power plug and plug-switch assembly are efficient. If oxidation is detected, clean immediately

 - In the event of activation of the RCCB, check the machine and arrange for repairs if necessary exclusively by specialised personnel.

11.5 Cleaning the tank

Clean the tank in the event of build-up of sediment on the base, or at least once a day. Failure to clean the tank could impair operation of the immersion pump used for circulation of the diamond blade cooling water.

To clean the tank, disassemble from the machine, lock the head, hold it by the arms and rinse with a direct water jet (this is to avoid direct contact of the water with electrical parts), then proceed with manual cleaning using cloths or brushes.

Take care not to damage cables when replacing the machine on the tank

Take care not to damage the pump when placing the machine on the surface

11.6 Blade replacement

The diamond blade is made of material that may be damaged when subject to high temperatures, and therefore must be cooled during the work phases.

To replace the blade, proceed as follows:

1. Block axial movement of the cutting head by means of the handwheels (ref.L, fig.1).
2. Disassemble the front guard (ref.P, fig.1).
3. Loosen the locknut by rotating clockwise (left thread), using a 19 mm wrench.
4. Move the cutting head forward slightly and incline to remove the blade from its seat.
5. Ensure that there are no foreign objects between the fixing flange and diamond blade. During disassembly, avoid use of tools that could dent or deform the flange.
6. Insert the new blade proceeding in reverse order of the operation described at point 4. Take special care to ensure correct direction of rotation of the diamond blade.
7. Tighten the blade locknut fully down by rotating anticlockwise (left thread), to a torque of 40 Nm.

 - Always disconnect the power plug before changing the disk.

11.7 Cleaning the cooling water supply circuit

At regular intervals (or when the flow rate of the blade cooling water is reduced) clean the cooling water supply circuit. To do this, disassemble the delivery nozzle (ref.P, fig.1) located inside the blade guard and clean in water.

Periodically clean the cooling water delivery line between the pump and valve and blade guard using water.

12. Residual risks and safety signs

Although the sawing machine has been manufactured fully in compliance with current regulations, residual risks exist that cannot be eliminated and involve the use of appropriate individual protection devices. Adequate warning signs fitted on the machine point out both the risks and the behaviour to be followed.

NOISE RISK



Ear protection must be worn

RISK OF INJURY TO THE HANDS



Safety gloves must be worn

RISK OF INJURY TO THE EYES



Eye protection must be worn

ABNORMAL USE RISK



Reading the manual before use is compulsory



Cutting with water is compulsory

DANGER DE COUPURE



DANGER D'ÉLECTROCUTION



DANGER RAYON LASER



Please be reminded that checking the use of IPDs is delegated to the employer.

14. Troubleshooting

⚠ - CAUTION!!! All maintenance operations must be performed exclusively with the machine switched off, with the selector set to "0" and the power plug disconnected from the mains.

Trouble	Causes	Remedies
The motor does not start when the start switch is pressed	Current does not reach the supply line	Check the line *
	The socket and plug are not connected properly	Restore correct connection
	The differential switch is off	Turn the differential switch on
	The power cable from the plug to the panel is cut off	Change the cable *
	An electric wire inside the motor terminal strip is cut off	Restore the connection *
Cooling water fails to reach the blade	An electric wire inside the panel is cut off	Change the switch *
	The start switch is faulty	Change the switch *
	Low water level in tank	Restore the water level
The blade does not cut	Pump filter clogged	Clean the pump filter
	Current fails to reach the pump	Check the pump electrical supply *
The blade does not cut	Pump failure	Change the pump *
	Blade fitted in the opposite direction to that of rotation	Remove the blade and reposition it in the direction shown on the blade label
	Worn blade	Change the blade

* Operation to be carried out by an electrician

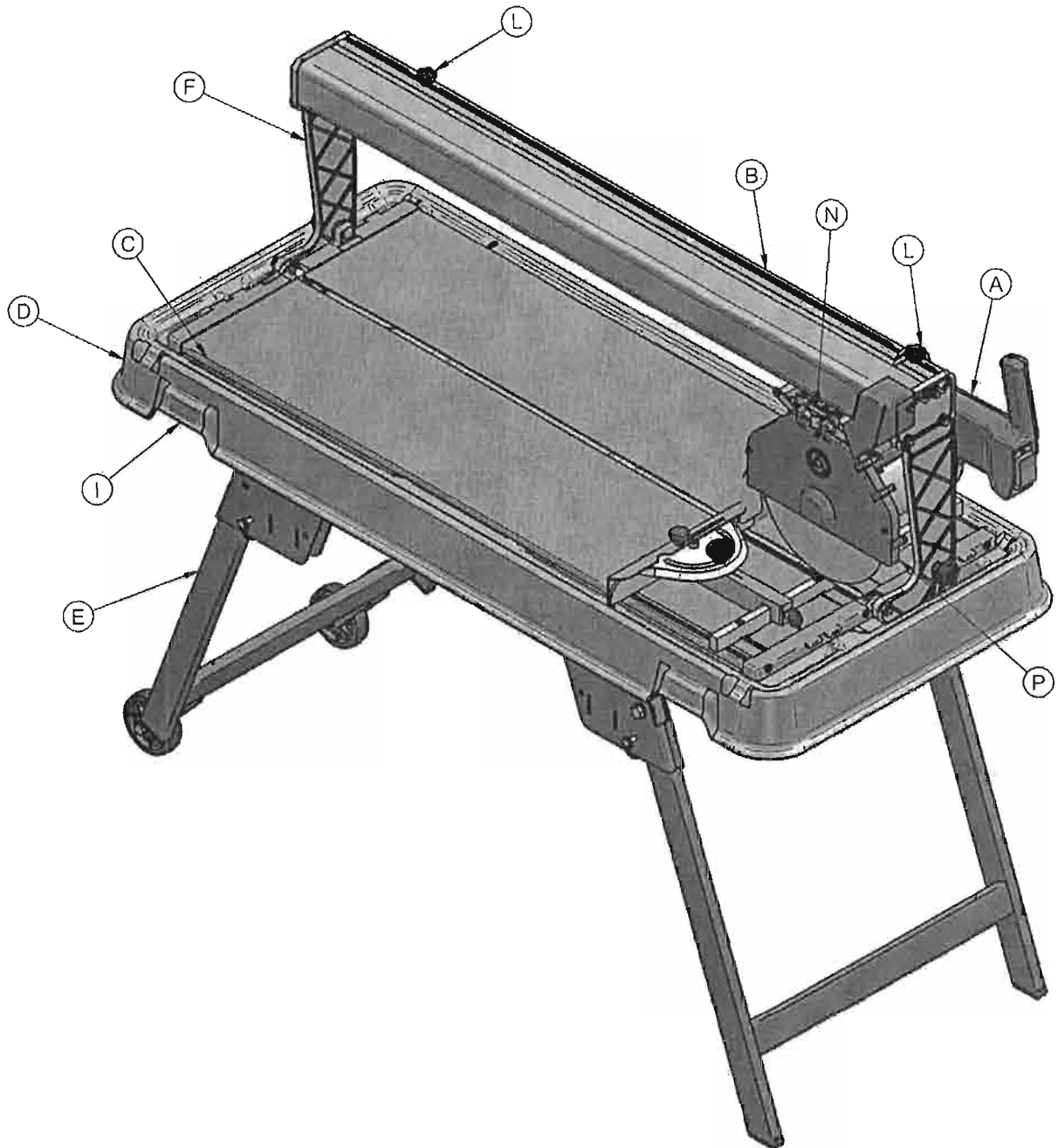

FIG. 1

FIG. 2

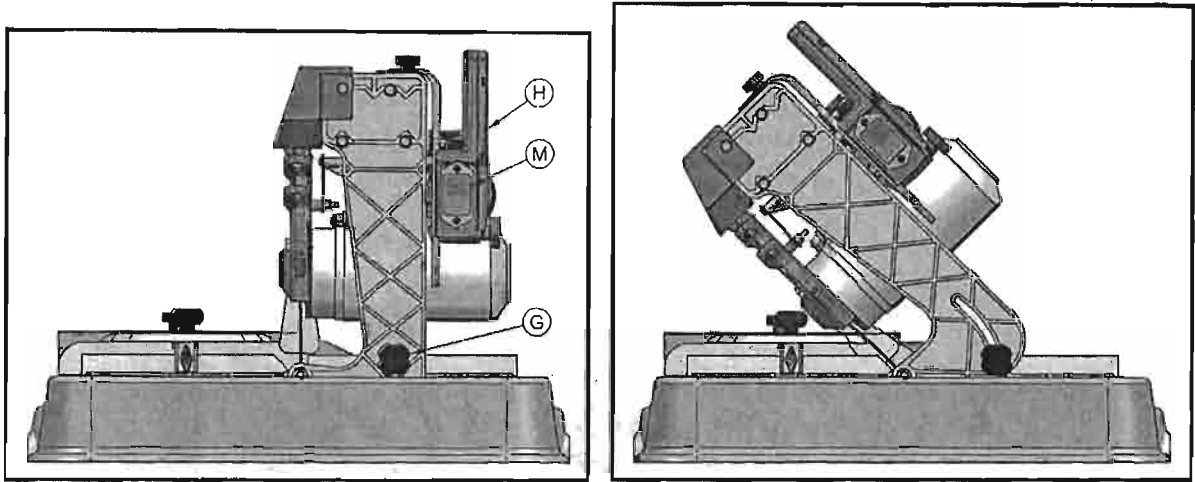

FIG. 3

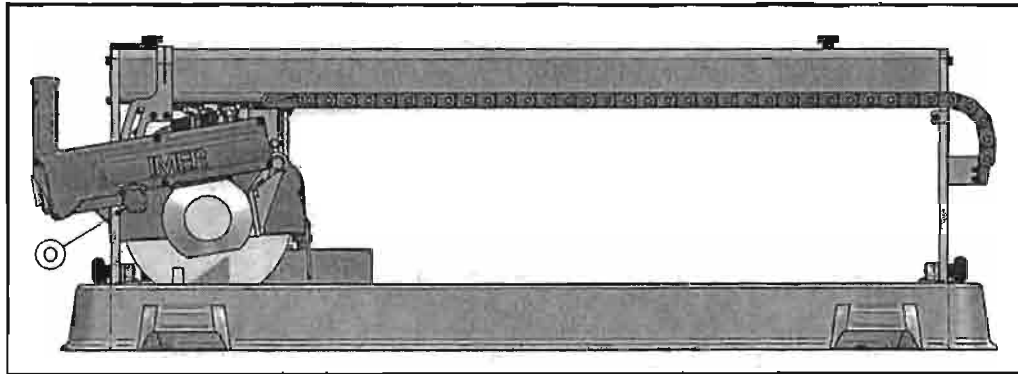
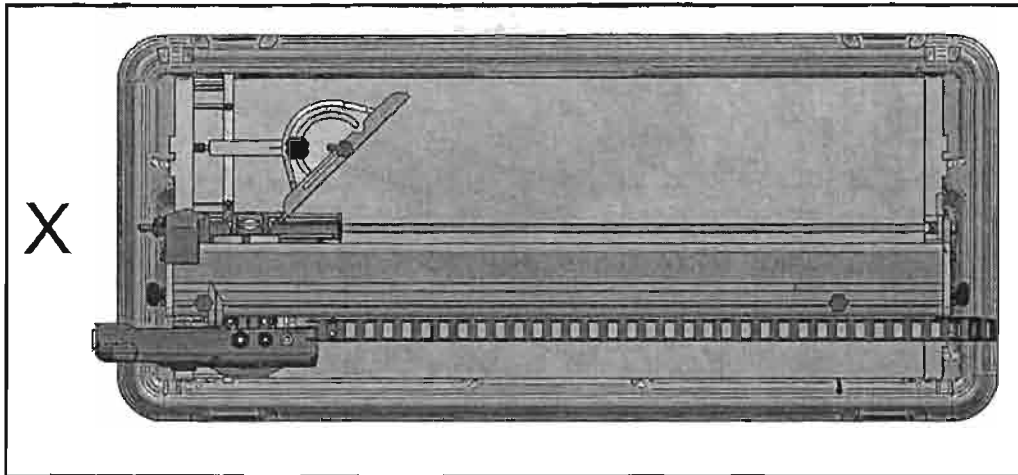
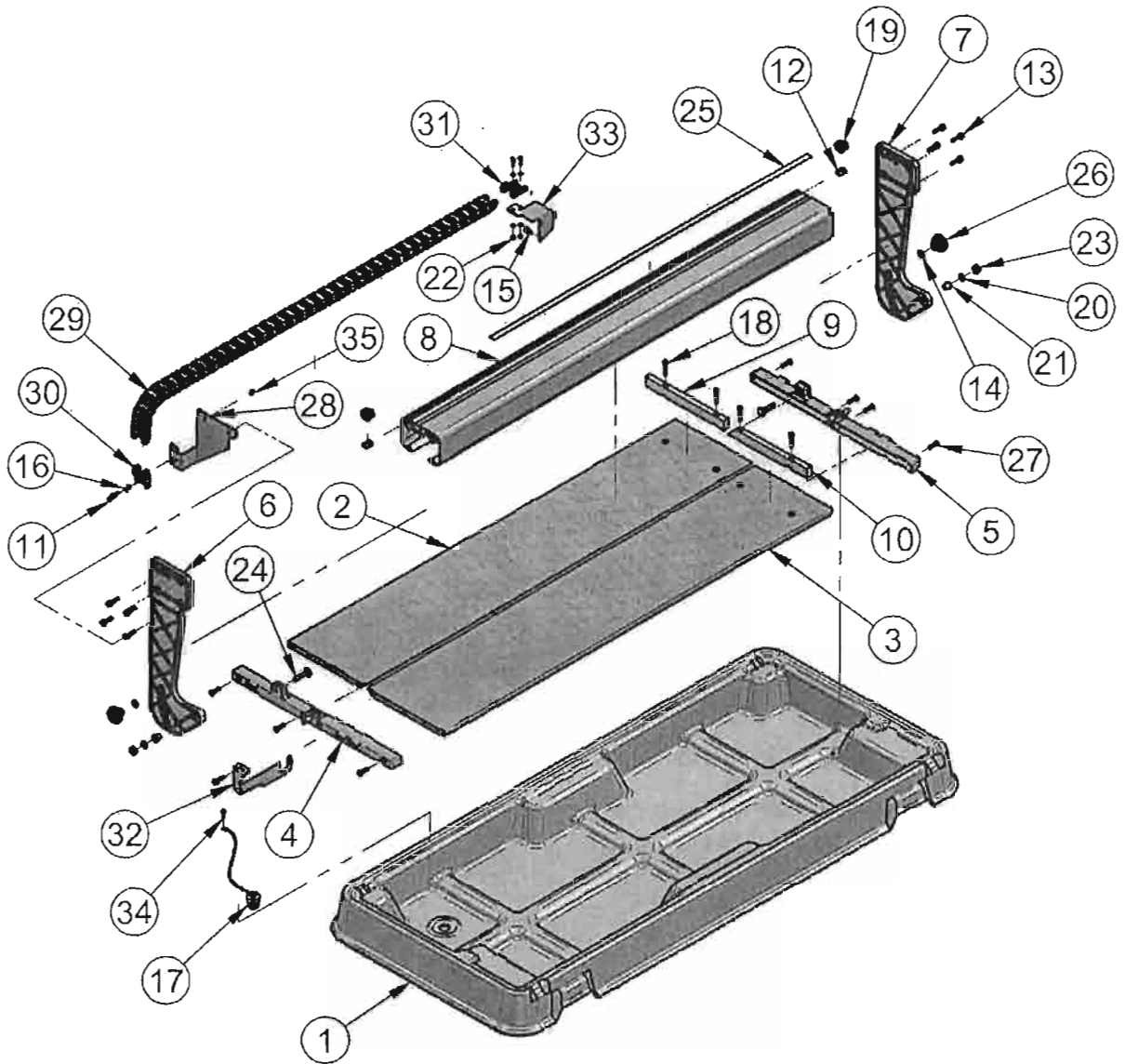

FIG. 4







TAV. 1 - MACHINE STRUCTURE			
REF.	CODE	DESCRIPTION	NOTES
1	3226951	TANK	
2	3226942	R.H. SURFACE	
3	3226943	L.H. SURFACE	
4	3226070	REAR SIDE	
5	3226069	FRONT SIDE	
6	3226359	REAR ARM	
7	3226357	FRONT ARM	
8	3227459	SLIDEWAY	
9	3226073	RIGHT FENCE	
10	3226074	LEFT FENCE	
11	3209797	BOLT	TE 5739 M5X16
12	3210071	T-NUT	
13	3210099	BOLT	TEFR 6X25
14	3210576	WASHER	D.8,4X17X1,5
15	3225750	BOLT	TEFR 6X10
16	2224529	WASHER	D.8X10
17	2235429	CAP	
18	2222545	BOLT	TCEI 5931 M6X30
19	3204865	KNOB	M6
20	3226087	WASHER	D.10,5X17X1,5
21	3226088	BUSHING	
22	2223927	NUT	7474 M5
23	2223920	NUT	7474 M10
24	3226747	BOLT	TTDE 5732 8X40
25	3226795	MILLIMETRED STRIP	
26	2284866	KNOB	M8
27	2222584	BOLT	TSPEI 5933 M6X25
28	3226944	BRACKET	
29	3226946	CABLE HOLDER CHAIN	
30	3226947	MALE TERMINAL	
31	3226948	FEMALE TERMINAL	
32	3226949	BRACKET	
33	3226950	BRACKET	
34	2222449	BOLT	TC 6954 3.5X19
35	3227488	CABLE DUCT	D.4

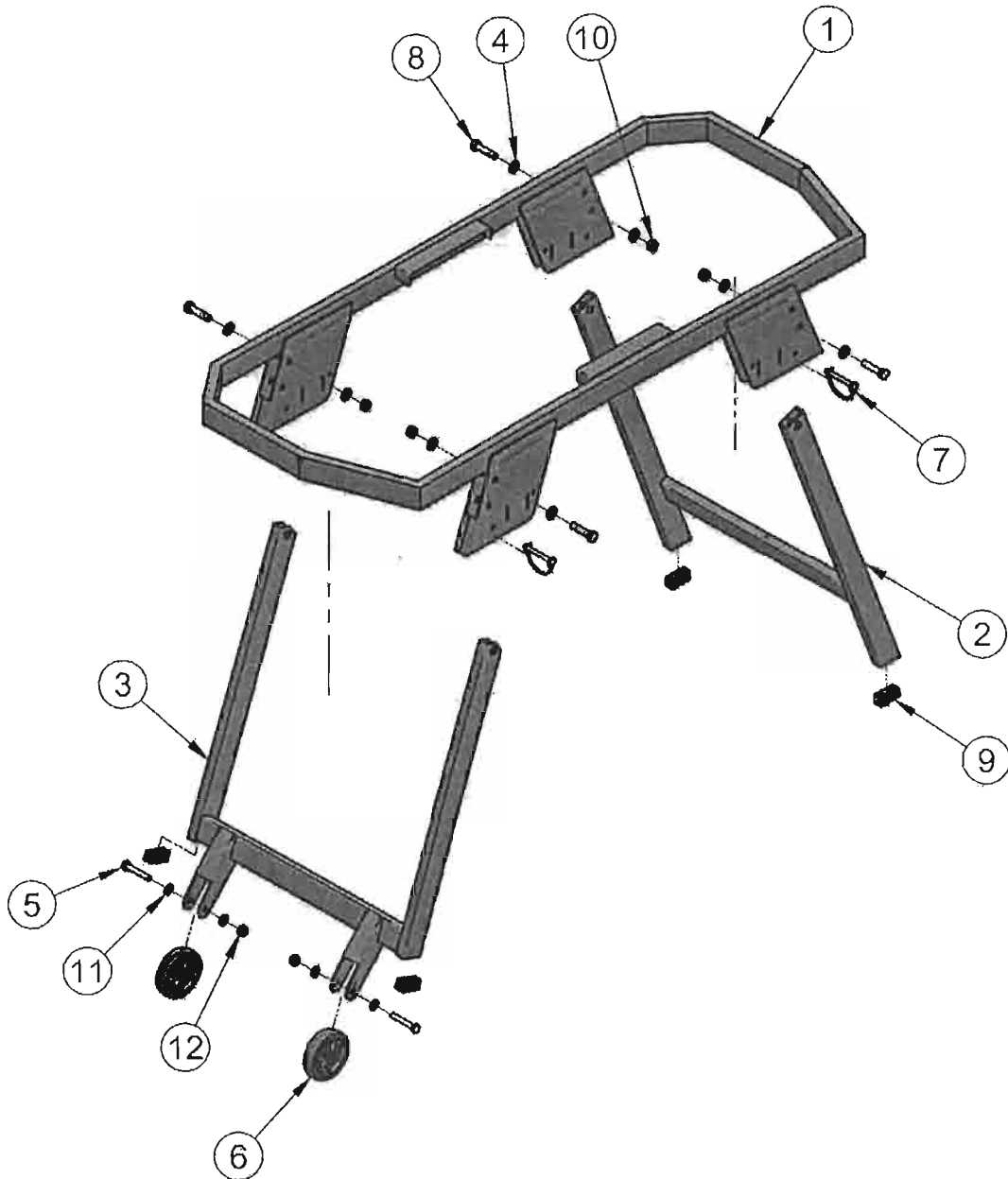

TAV. 2 - COMPLETE FRAME			
REF.	CODE	DESCRIPTION	NOTES
1	3227025	FRAME	
2	3226982	FRONT LEGS	
3	3226903	REAR LEGS	
4	2224380	WASHER	6592 D.12X25
5	3204604	BOLT	TE 5739 M10X60
6	3205257	WHEEL	
7	3223143	PIN	8X70 Z
8	3225731	BOLT	TE 5739 M12X50
9	3226976	CAP	
10	2223921	NUT	7474 M12
11	2224340	WASHER	6592 D.10X21
12	2223920	NUT	7474 M10

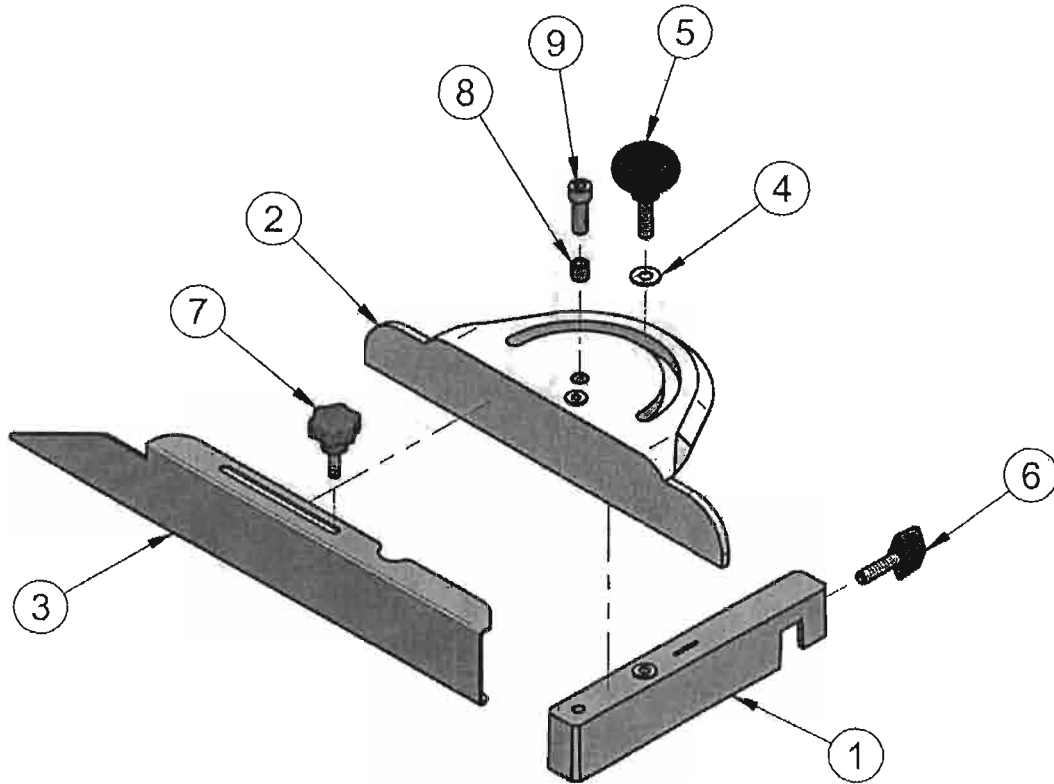

3226358		TAV. 3 - COMPLETE GONIOMETER	
REF.	CODE	DESCRIPTION	NOTES
1	3226076	GONIOMETER SUPPORT	
2	3226078	GONIOMETER	
3	3226360	SLIDING ROD	
4	2224140	WASHER	6593 D.8X18
5	3207939	HANDWHEEL	M8X30
6	3211381	HANDWHEEL	M8X30
7	3223279	HANDWHEEL	M6X20
8	*	SPACER	
9	2222511	BOLT	TCEI 5931 M8X25

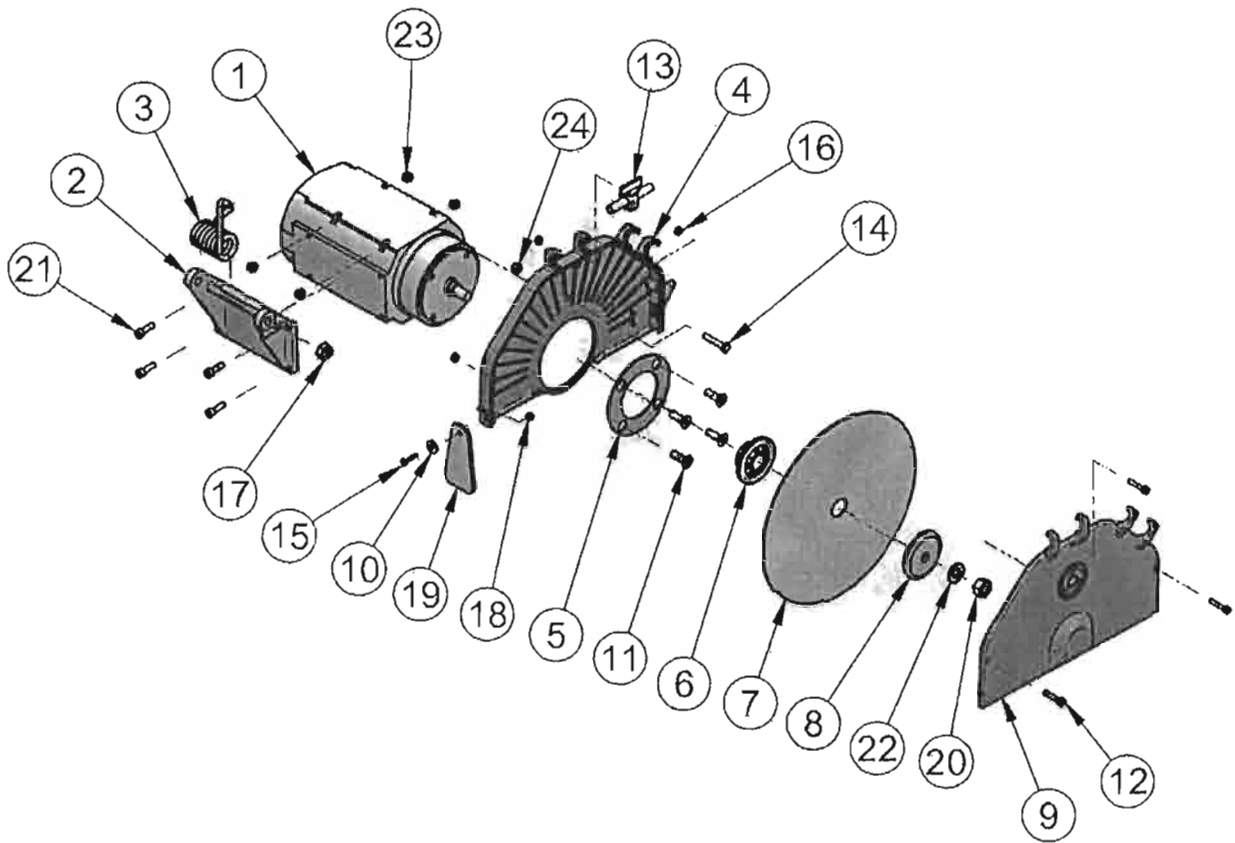

TAV. 4 - BLADE PROTECTION MOTOR ASSEMBLY			
REF.	CODE	DESCRIPTION	NOTES
1	3211936 3211938	MOTOR	230V 110V
2	3210038	ENGINE SUPPORT	
3	3210087	SPRING	
4	3211935	BLADE GUARD	
5	3210043	SPACER BRACKET	
6	3210044	INNER FLANGE	
7	1193852	BLADE	
8	3210046	OUTER FLANGE	
9	3211933	BLADE GUARD	
10	2224535	WASHER	
11	3201339	BOLT	TSPEI 5933 8X25
12	3204399	BOLT	TCEI 5931 M5X25
13	3207884	COCK	
14	3209060	BOLT	TE 8.8 5737 6X35
15	2222001	BOLT	TE 8.8 5737 4X20
16	2223352	NUT	5588 D.5
17	2223920	NUT	7474 M10
18	2223926	NUT	7473 M4
19	3210050	SPRAY SHIELD	
20	3210053	NUT	5588 M12 Z SX
21	2222540	BOLT	TCEI 5931 6X20
22	2224380	WASHER	6592 D.12X25
23	2223280	NUT	5588 M6
24	2223924	NUT	7473 M6

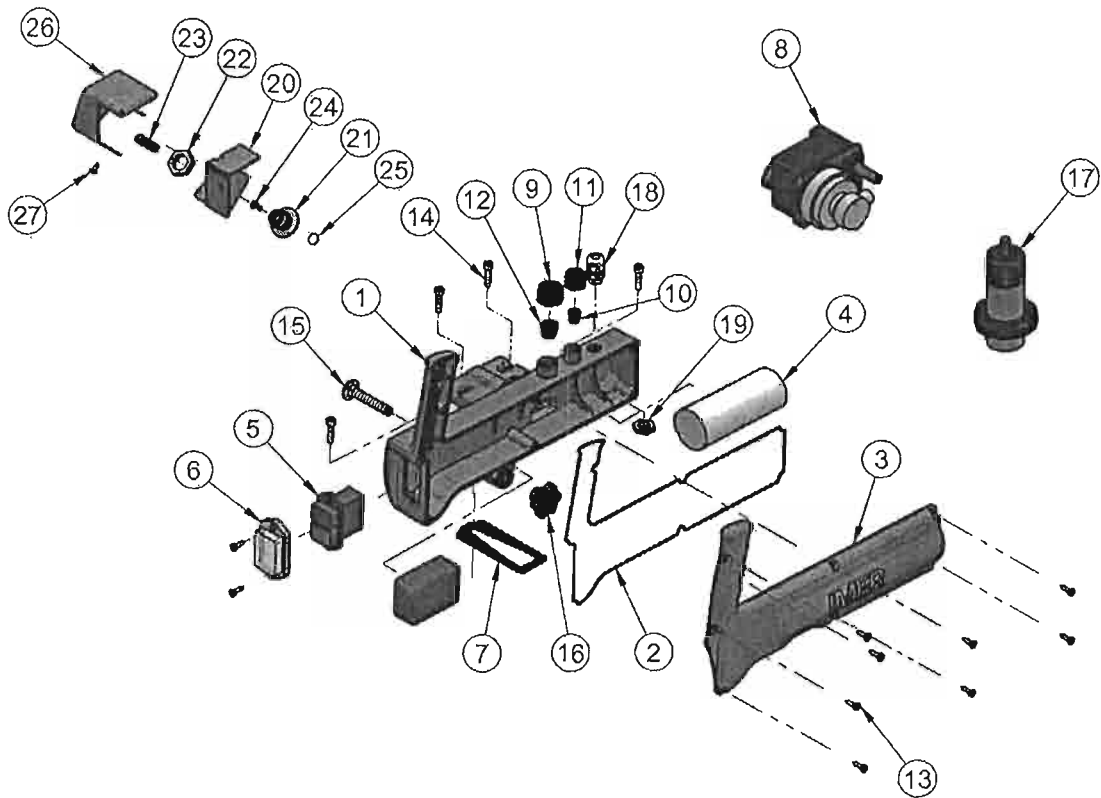

TAV. 5 - ELECTRIC PANEL			
REF.	CODE	DESCRIPTION	NOTES
1	3227466	JUNCTION BOX	
2	3210114	GASKET	
3	3210085	COVER	
4	3210239 3210129	CAPACITOR	110V 230V
5	3210872 3209337	SWITCH	110V 230V
6	3209340	LEAKAGE PROTECTION	
7	3225596	GASKET	
8	3227217 3227212	WATER PUMP	110V 230V
9	3226095	CABLE GLAND LOCKING RING	PG 16
10	3226101	CABLE GLAND GROMMET	PG 16
11	3226098	CABLE GLAND LOCKING RING	PG 11
12	3226100	CABLE GLAND GROMMET	PG 11
13	3210116	BOLT	TCTC 4,2X16
14	2222541	BOLT	TCEI 5931 6X25
15	3210096	BOLT	TTCQ 5732-65 M8X60
16	2284866	HANDWHEEL	M8X30
17	3210608 3210609	PLUG + ELECTRIC CABLE	110V 230V
18	3227508	CABLE CLAMP	PG 9
19	3227487	CABLE GLAND NUT	PG 9
20	3227481	SUPPORT	
21	3227483	ADJUSTMENT BLOCK	
22	3227489	CABLE GLAND NUT	M20x1,5
23	3227491	LASER + POWER SUPPLY	
24	3207155	BOLT	TC PH 7687 M4X10
25	3227490	LASER GUARD	
26	3227482	COVER	
27	2222424	BOLT	TC PH 6954 4,2X9,5

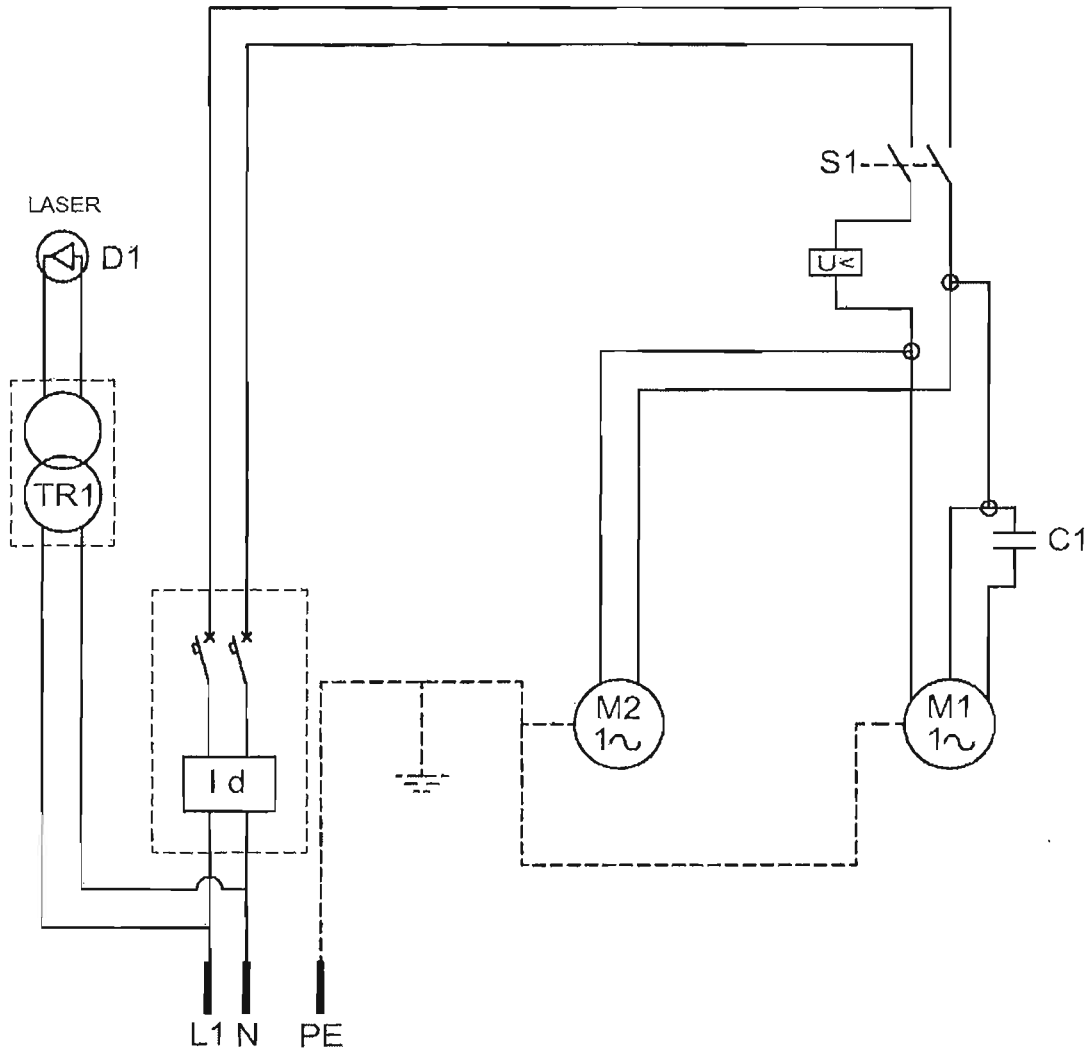

WIRING DIAGRAM		
REF.	DESCRIPTION	NOTES
S1	CONTROL SWITCH	
C1	CAPACITOR	
PE	EARTHING CABLE	
N	NEUTRAL LINE CABLE	
L1	PHASE LINE CONDUCTOR	
M1	BLADE MOTOR	
M2	PUMP MOTOR	
ID	CURRENT CIRCUIT BREAKER	KIT 230V COD.1169245 KIT 110V COD.1169249
TR1	POWER SUPPLY	
D1	LASER EMITTER	

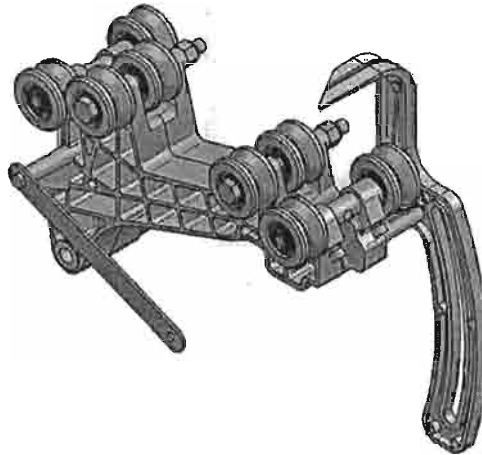
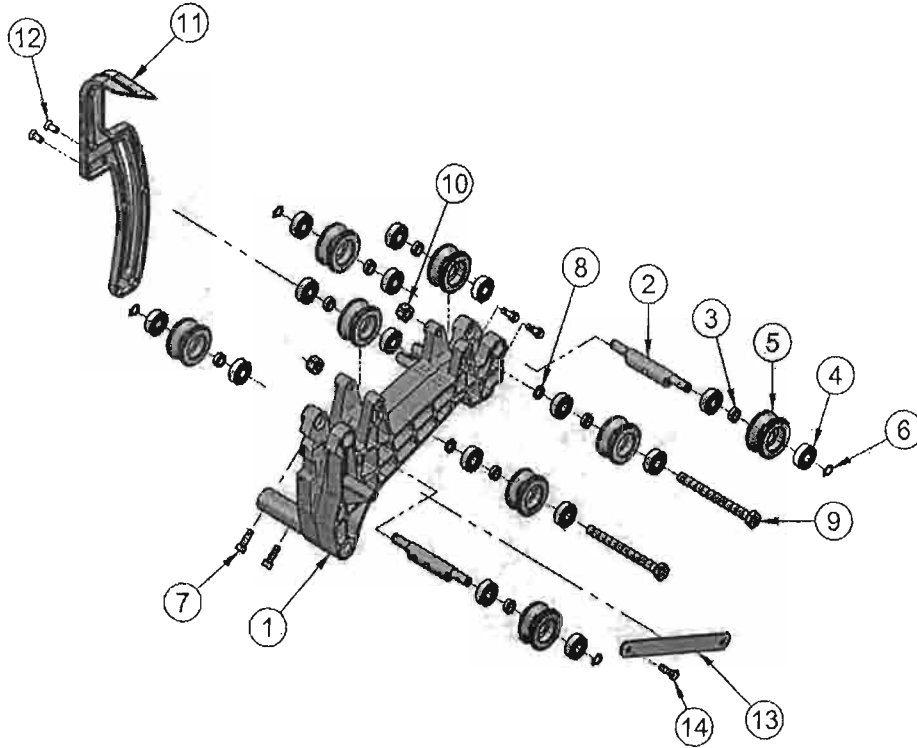

TAV. 6 - CARRIAGE			
REF.	CODE	DESCRIPTION	NOTES
1	3210031	CARRIAGE	
2	3210032	CAM	
3	3207393	SPACER BRACKET	
4	3204945	BEARING	608 2RS1
5	3207397	WHEEL ASSEMBLY	
6	3210627	RING	
7	3210036	BOLT	TCEI.5931 M5X16
8	3210622	SPACER BRACKET	
9	2222114	BOLT	TE 5737 M8X90
10	2223923	NUT	7473 M8
11	3210028	CARRIAGE BLOCK	
12	3210105	BOLT	TSP PH M5X12
13	3210029	BLADE GUARD	
14	2222000	BOLT	TE 5739 M5X16

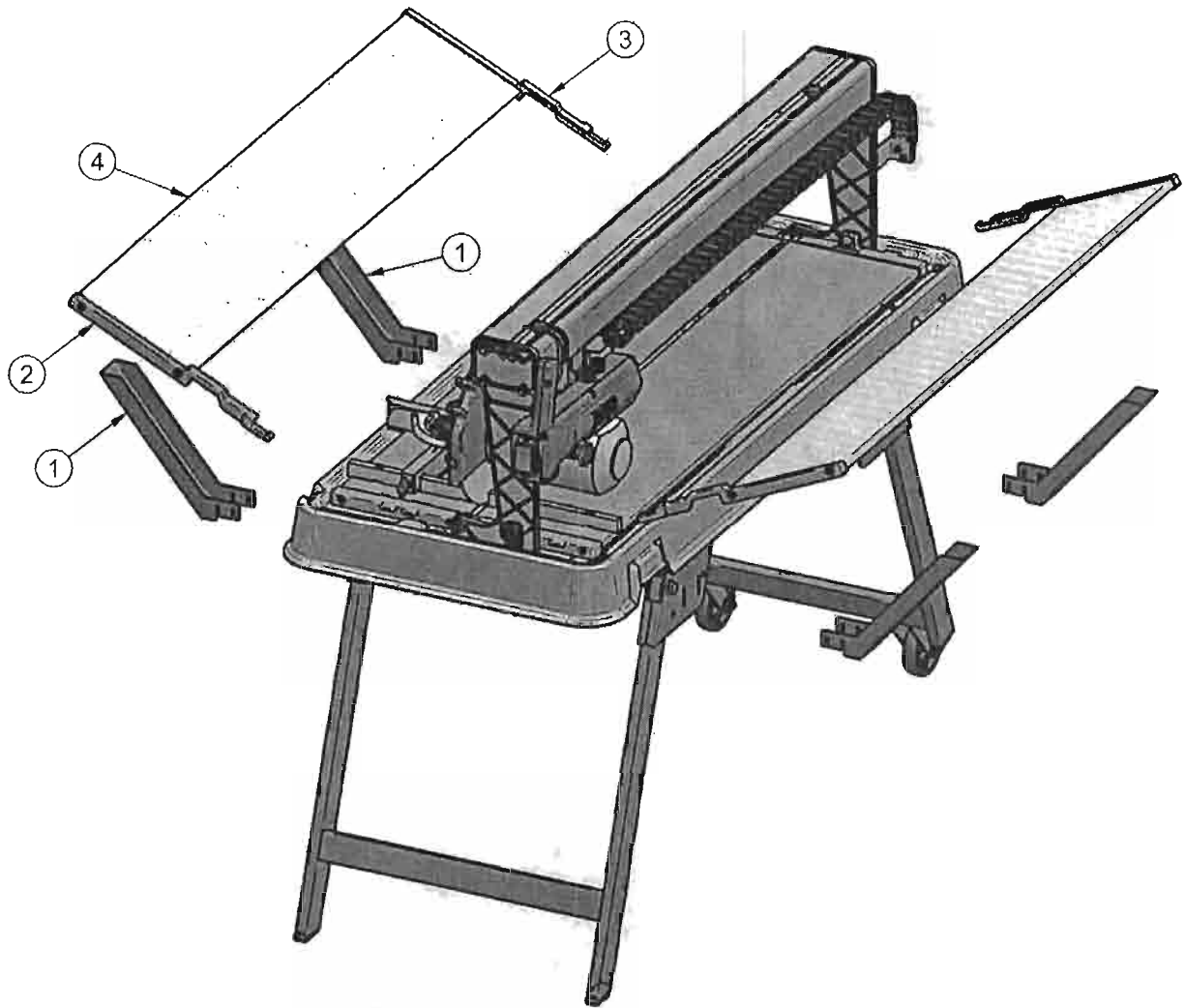

FIG. 6

COD.1188176		TAV. 7 - SIDE ROLLER	
REF.	CODE	DESCRIPTION	NOTES
1	3226953	SUPPORT	
2	3226146	SUPPORT	
3	3226145	SUPPORT	
4	3226952	SIDE ROLLER	

ONE YEAR WARRANTY

We warrant to the original purchaser that the IMER equipment described herein (the "equipment") shall be free from defects in material and workmanship under normal use and service for which it was intended for a period of one (1) year from the date of purchase by the original purchaser.

Our obligation under this warranty is expressly limited to replacing or repairing, free of charge, F.O.B. our designated service facility, such part or parts of the equipment as our inspection shall disclose to be defective. Parts such as engines, motors, pumps, valves, electric motors, etc. furnished by us but not manufactured by us will carry only the warranty of the manufacturer. Transportation charges or duties shall be borne by the purchaser. This shall be the limit of our liability with respect to the quality of the equipment.

This warranty shall not apply to any equipment, or parts thereof, which has been damaged by reason of accident, negligence, unreasonable use, faulty repairs, or which has not been maintained and operated in accordance with our printed instructions for our equipment. Further, this warranty is void if the equipment, or any of its components, is altered or modified in any way.

THIS WARRANTY IS EXPRESSLY IN LIEU OF ALL OTHER WARRANTIES, EXPRESSED OR IMPLIED, INCLUDING ANY IMPLIED WARRANTY OF MERCHANTABILITY OF FITNESS FOR A PARTICULAR PURPOSE.

We make no other warranty, representation or guarantee, nor is anyone authorized to make one on our behalf. We shall not be liable for any consequential damage of any kind, including loss or damage resulting, directly or indirectly, from the use or loss of use of the machine. Without limiting the generality of the foregoing, this exclusion from liability embraces the purchase's expenses for downtime, damages for which the purchaser may be liable to other persons, damages to property, and injury or death of any persons.

This warranty shall not be deemed to cover maintenance parts, including but not limited to blades, belts, hoses, hydraulic oil or filters, for which we shall have no responsibility or liability whatsoever.

IMER U.S.A. Inc.
221 Westhampton Place
Capitol Heights, MD 20743
Ph. 301.336.3700
Fax 301.336.6687
Toll Free: 800.275.5463
www.imerusa.com
info@imerusa.com

COMBI 250-1000
110 VOLT

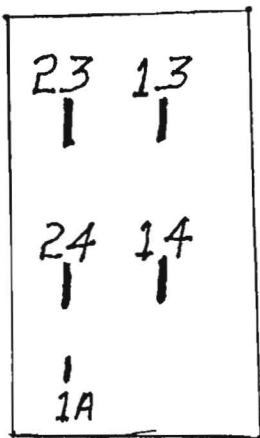
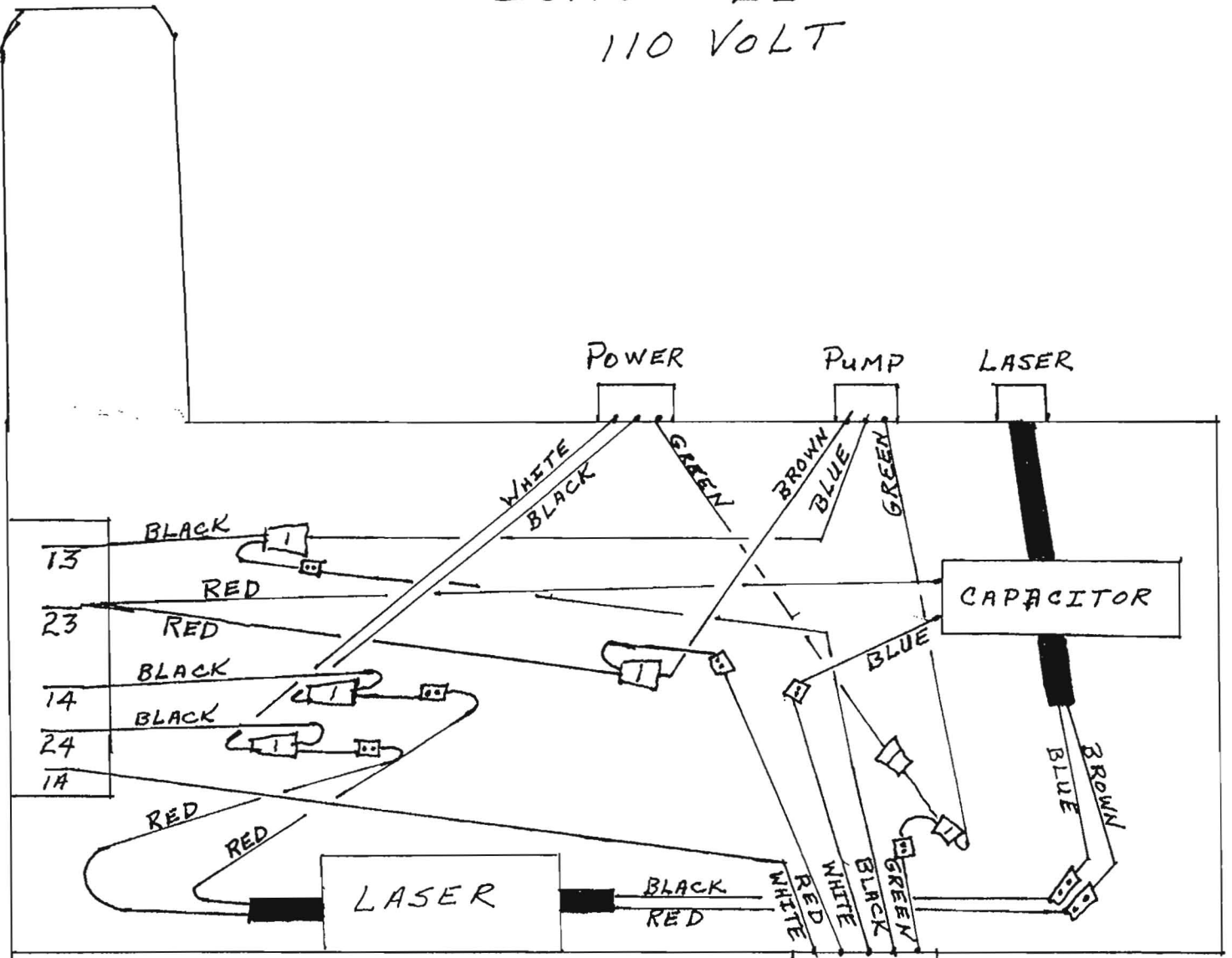

SWITCH

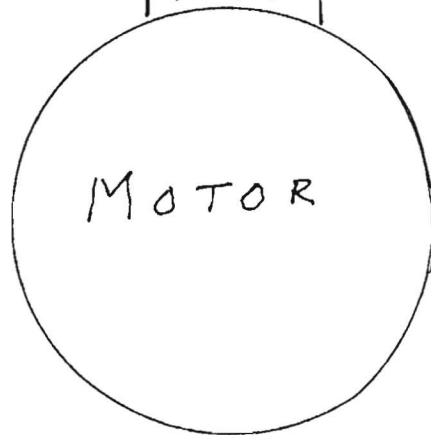



This is a contact addendum to our manuals

Imer USA East

221 Westhampton Pl
Capitol Heights, MD 20743

Phone: 301-336-3700

Fax: 301-336-6687

Order Fax:301-336-5811

Imer USA West

3654 Enterprise Ave
Hayward, CA 94545

www.imerusa.com

800-275-5463