

BEF200-1 & BEF60 Edger Operating Manual

This manual is provided to persons purchasing an SPE machine and may not be reproduced in part or full without written permission of SPE International Ltd.

This manual provides the basic information required and is only to be used as a guideline. The SPE machines are manufactured and covered by SPE design registrations granted and pending. SPE International Ltd reserves the right to alter the equipment design and specification as required without notice.

The SPE product range is subject to amendment and improvement as a result of on going research



Honeyholes Lane, Dunholme, Lincoln LN2 3SU, England
Tel: +44 (0) 1673 860709 Fax: +44 (0) 1673 861119
Email: sales@spe-int.com

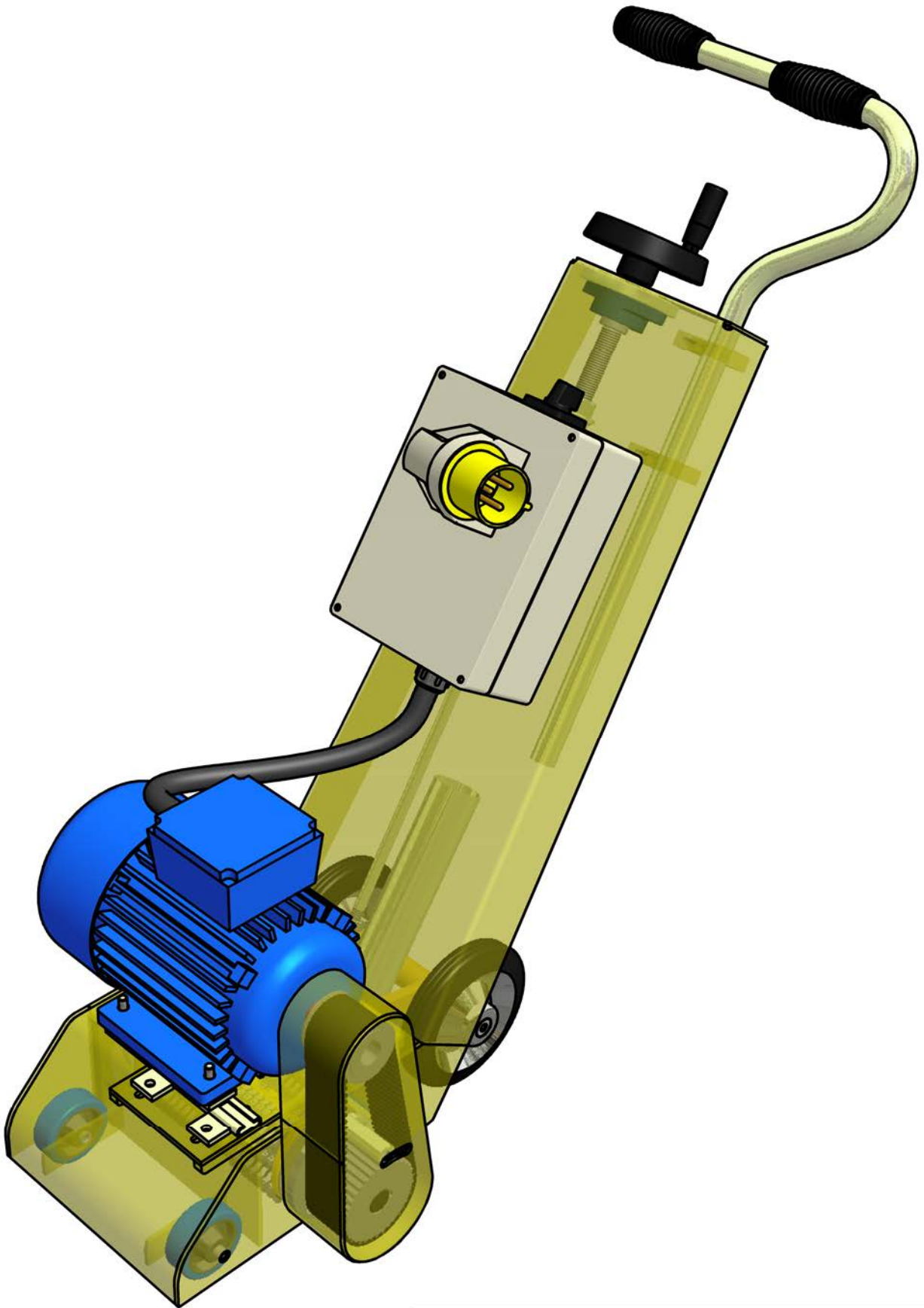

	<p>SPE International Limited Honeyholes Lane, Dunholme Lincoln, LN2 3SU, England Tel: +44 (0) 1673 860 709 or +44 (0) 1673 860 330 Fax: +44 (0) 1673 861 119 Web Site: http://www.spe-int.com E-mail: sales@spe-int.com</p>
<p>Surface Preparation Equipment™</p>	
<p>BEF 200</p>	



BEF200-1
Operating Manual

BEF 200 OPERATING MANUAL

This manual covers to the best of our knowledge, the operation and maintenance of the **BEF200** Multi-Plane. Before operation of the equipment the manual should be read and understood by the operator. The safety regulations must be followed at all times. Service of electrical components should be carried out by authorised personnel. Failure to follow these instructions could result in damage to the machine and/or serious personal injury or death.

WARNING

Failure to follow these instructions may result in serious personal injury or death. SPE disclaims all responsibility for damage to persons or objects arising as a consequence of incorrect handling of the machine and failure to inspect the machine for damage or other faults that may influence the operation prior to starting work.

INDEX

Page No

1	Starting Work General Operation
2	Electrical Instructions
3	Maintenance
4	Cutter Drum Removal
5	Basic Maintenance Checklist
6	Safety
7-9	Accessories
10-12	Cutter Drum Set Up
13	Spare Parts Breakdown BEF200
14	Body Components
15	Drum Drive Components
16	Wiring Diagram
17	Electrical Panel Component List
18	BEF60 General Operation
19	Spare Parts Breakdown BEF60 Edger
20	BEF60 Body and Drum Components
21	Specifications Electrical Requirements
22-23	Noise and Vibration Assessment
24	Warranty
25	Declaration of Conformity
26	Conditions of Sale



STARTING WORK

Check the following prior to starting equipment

- Check condition of cutter drum assembly
- Check all bolts for tightness
- Check drive belt condition and tension
- Check plugs and cables for damage

1. Before starting the machine ensure that the cutter drum assembly is clear of the ground by turning the hand wheel anti clockwise to full height. The machine is now locked in position and cannot accidentally roll away if left unattended.
2. Adjust the handlebar to a comfortable height and position.
3. Connect the power supply – See page 2 for further details
4. Connect the vacuum hose to the dust port at the rear of the machine if a dust control vacuum is being used.
5. Start the motor by turning the switch on the panel to the start position. Hold for 2-3 seconds for the motor to start and release. The switch will return to its run position.
6. Slowly rotate the hand wheel until the cutters make contact with the surface to be prepared. It is essential that the cutters are not lowered too far and too hard onto the surface as serious damage could be caused to the machine and cutter drum assembly. The cutters must be allowed to "float" on the cutter shafts without excessive downward pressure. This floating action allows the cutters to perform as the designer intended (i.e.) as flails rather than as grinders or picks. The machine should operate smoothly with a minimum of vibration.

GENERAL OPERATION

- Excessive downward pressure on the cutters may marginally improve the work rate/finish but the definite increase in wear rates on the cutter drum assembly, machine components and overloading the motor is the negative result.
- Remember two light passes are quicker and more cost effective than one slow heavy pass. Tests have proven conclusively that heavy downward pressure reduces cutter and drum life by over 50%.
- To remove dust, connect an industrial dust collector or vacuum to the 50mm port (part no 9109) at the rear of the machine. We recommend the SPE VAC316 for almost 100% dust control. In the absence of a dust control unit it is acceptable to spray water onto the surface or to feed water down the vacuum port. Cutter drum assembly life is increased by around 10% when operating the machine in this way.
(Note: Electrical motors and switches are not waterproof, take care to protect them from splashes.)
- The BEF200 is normally operated in a forward direction, the operator varies the speed of travel to determine the final finish, having already pre-set the depth control. It is permissible to operate the machine with a backwards and forwards action. Each pass should be overlapped to produce a uniform finish.

To cease operation, raise the cutter drum assembly clear of the ground and then turn the switch to the 'off' position.



BEF200-1 Operating Manual

ELECTRICAL INSTRUCTIONS

The points raised are based on many years practical experience not on text book theory. If you follow these guidelines your time on site will be productive rather than frustrating.

The BEF200-1 machine is supplied with a specially commissioned 110v electric motor and starter switch assembly. Each unit is fully tested and the safety overload relays have been calibrated and set according to the manufacturers specifications. In the event of the malfunction on a new machine the owner should first check that the power supply on site is suitable and adequate.

The motor requires a 32amp 110v power supply.

To avoid voltage drop the cable size must be a minimum of 4.0mm 3 core. Maximum length of cable not to exceed 30 metres.

The transformer must have a continuous rated output of at least 3 KVA. In practice this means that a 5 KVA transformer must be used. Manufacturers of transformers have different methods of rating their equipment.

The transformer and all cables should be fitted with 32 amp 110v plugs and sockets.

All cables should be fully uncoiled and never left wrapped around cable reels or tied in loops.

If the power is to be generated, the BEF200-1 requires a minimum 8kva generator.

The motor is protected with a safety trip in the panel. Should the trip be activated, you must isolate the power supply, open the panel and reset the trip.

If the motor repeatedly cuts out then it will be damaged. The possible causes are either an inadequate power supply, overloading of the machine, or an electrical fault. The machine can only be overloaded by setting the depth of cut too low.



MAINTENANCE

Prior to any maintenance or adjustment isolate the power supply.

AFTER USE:

Clean the machine to remove all the build up of dust and surface residue. If using a hose pipe or pressure washer take care that water is not directed onto electrical components and switches.

(Note: Motors and switches are not waterproof)

Ensure the height adjustment thread is cleaned and then lightly oiled. Periodically it should be removed and the female, threaded section cleaned out and oiled regularly to maintain a light, smooth height adjustment.

The HTD drive belt will give a long and trouble free operating life if basic procedures are followed.

Daily, check the drive pulleys for build up of deposits and trapped stones. Check the belt and teeth for surface cuts and cracks, once the surface of the belt is damaged it will soon fail. Build up of dirt in the pulley teeth causes two problems: The belt becomes tight and as the teeth can no longer fully mesh properly, all the power is transmitted through the tip of the teeth with obvious negative results.

The drive belt is tensioned by sliding the motor along the adjusting rails. It is important that the drive belt is not over tensioned. It should be tight enough for all teeth to make full contact but should allow a little movement to allow for "self alignment".

Serious damage could be caused to the drive shaft, drive shaft bearings and drive motor if the belt is excessively tight. Generally when the motor is started and run, a tight belt can be detected by a low hum/whistle.

Note: Never operate the BEF200 without a belt guard.

All components should be checked daily for tightness and the drive belt for tension.



CUTTER DRUM REMOVAL

Isolate the power supply and ensure the cutter drum has come to a complete standstill.

Adjust the height adjustment hand wheel so that the cutters are clear of the ground.

Loosen the four 8mm set screws (Part No. 9237) and remove the side plate. When new this cover can stick and it may be necessary to lever off the plate with a screwdriver.

With the side plate (Part No. 9101) removed the cutter drum will simply slide off the drive shaft.

Fitting a new cutter head is simply a reversal of the above procedure.
(Note: It is essential that the four 8mm set screws are tight at all times.)

Cutter drum maintenance:

When changing a cutter drum always check that the flail shafts are not excessively worn with pronounced grooves and also that the centres of cutters and spacers are not elongated or beginning to mushroom. The screws which hold the drum end plates in position must be tight and in good condition.

It is expensive and false economy to run the cutter drum components until they break. Try to establish a routine for replacing wear parts before they cause problems. Remember the drum assembly is hitting concrete with great force 1,800 times every minute! Expenditure on consumables must be expected and built into all job costing.

While changing the drum the condition of the drive shaft and side plate bearings should be checked. If any roughness, side play or leakage of grease is detected, new bearings should be fitted. Lightly oiling the drive shaft will prevent a built up of rust which could cause difficulty when changing the drum.

The drive shaft is manufactured from high quality steel and then heat treated to produce the special properties required. The shaft is extremely strong and virtually unbreakable when used as intended. If, however, sideways pressure is exerted on the shaft while it is not supported by the side plate bearing then it can be bent.

With the drum removed check that the vacuum port is free from blockages and that the dust skirt is in good condition.



BASIC MAINTENANCE CHECKLIST

DAILY: (or every 8hrs to 10hrs)

- Check the cutters
- Check the flail shafts
- Check all nuts and bolts for tightness
- Check the belt tension
- Check the plugs and cables

WEEKLY:

- All the above with the following: -
- Grease all moving parts on the height adjustment mechanism
- Remove the side plate
- Check the drum
- Check the drive shaft bearings
- Check the drive bush
- Check the drive shaft
- Check the support wheels and grease.

MONTHLY:

- All the above with the following: -
- Strip down fully the winding mechanism
- Clean all threads and re grease



BEF200-1 Operating Manual

SAFETY

Only trained operatives should be allowed to work the BEF200.

All operatives should wear ear defenders, goggles and an effective dust mask.

Note: It is possible that the noise level produced by the BEF200 could exceed 90dbA. Personal noise protection must be worn.

To control dust it is recommended that an SPE316 dust control unit is fitted.





Never leave the BEF200 unattended while in use. Always stop the motor and set the height control to "Park" (height adjustment fully up) before leaving the machine.





Always ensure that all power leads are disconnected before attempting to service the machine. The service of electrical components should be carried out by authorised personnel. Never remove the side plate or belt guard until the cutter drum has come to a complete standstill. Never tip the machine backwards until the cutters have come to rest.

Never operate the machine outdoors in wet conditions as the electrical components are not waterproof.

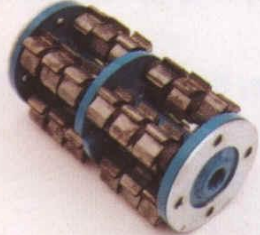
Noise and vibration will occur at various levels dependent on the attachments and work being completed. SPE have assessments conducted under test conditions detailed in the operating manual. (See page 22). However it is recommended that additional tests are taken on site to provide the operator with accurate information on using the equipment within the guidelines laid down by the Health & Safety Executive

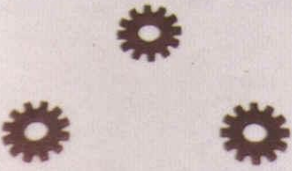
ACCESSORIES

	Part No	Description	Application
	BEF 60	Edger attachment for the BEF 200 and other makes of Planers and Scabblers.	Enables outer perimeter edges next to vertical walls or upstands to be prepared with the same type of cutter configurations as the BEF 200. Can be used dust free having a 50mm dust port.
	9276	Heavy duty drum complete with flail shafts for the BEF 60 edger.	For use with various cutter configurations
	9279	Heavy duty flail shaft for the BEF 60.	Hardened cutter shaft.
	20001	Heavy duty drum complete with T.C.T. cutters and spacers.	For all concrete texturing, scabbling, planing and grooving applications. Also for the removal of road markings, roof chippings and brittle coatings. Use on heavy applications for longer cutter life and higher output.
	20002	Heavy duty drum complete with beam flails.	For the removal of paint, laitance and coatings from floors. De-rusting and descaling ship decks. Also used removing build up of grease, dirt and ice deposits. Keying of concrete when a fine textured surface is required.
	20003	Heavy duty drum complete with milling cutters and spacers.	For the removal of thermoplastic road/runway markings. Very efficient and cost effective with none of the problems associated with burning off thermoplastics. Also for removal of bituminous and rubber deposits.

	<p>45500</p>	<p>T.C.T. Cutter: 5 point hardened steel cutter with tungsten carbide insert.</p>	<p>For all concrete texturing, scabbling, planing and grooving applications. Also for the removal of road markings, roof chippings and brittle coatings. Use on heavy applications for longer cutter life and higher output.</p>
	<p>45120</p>	<p>Beam Cutter: Heat treated steel cutter.</p>	<p>For the removal of paint, laitance and coatings from floors. De-rusting and de-scaling ship decks. Also used for removing build-up of grease, dirt and ice deposits. Keying of concrete when a fine textured surface is required.</p>
	<p>45600</p>	<p>Milling Cutter: Tipped with tungsten carbide.</p>	<p>For the removal of thermoplastic road/runway markings, rubber based deposits, cold plastic coatings from asphalt and concrete.</p>
	<p>20020</p>	<p>Wire brush crimped.</p>	<p>Removal of light deposits, rust. Cleaning and polishing steel.</p>
	<p>20021</p>	<p>Wire brush twist knot.</p>	<p>Removal of laitance, grease, oil, rubber deposits, rust and flaky paint.</p>
	<p>20000</p>	<p>Heavy Duty drum complete with flail shafts.</p>	<p>For use with various cutter configurations.</p>

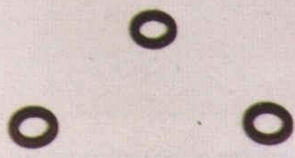

BEF200-1
Operating Manual

 Four dark, cylindrical metal shafts of varying lengths are shown against a light background.	20010	Heavy duty flail shaft.	Hardened cutter shaft.
 Three small, circular metal washers with a central hole are shown against a light background.	24140	Spacing washer.	Hardened spacing washer

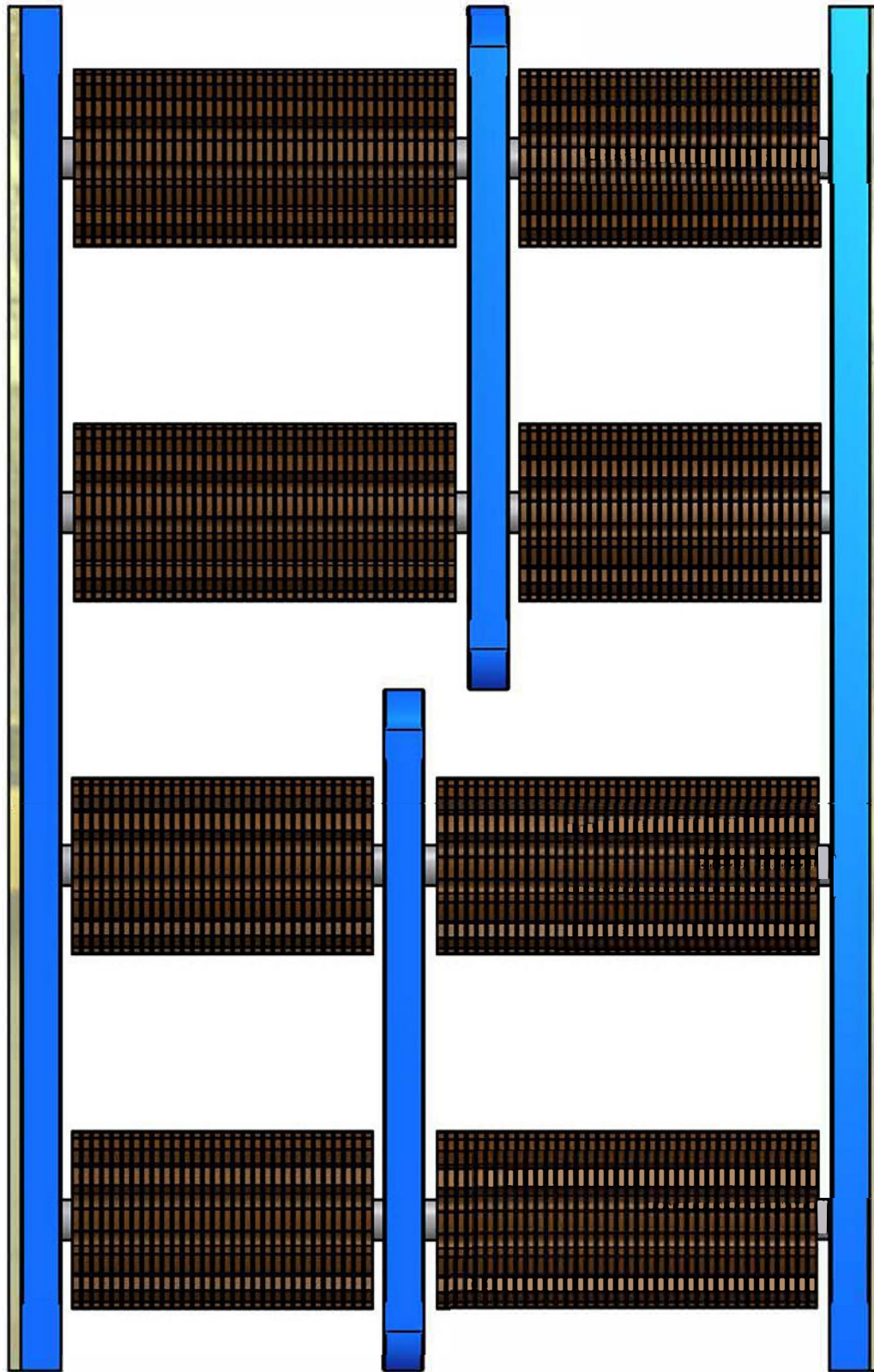

Parts List

QTY	SPE PART NUMBER	DESCRIPTION
228	45120	Beam Cutter

This drawing should not be used, copied, shown or handed to a third party without the prior written consent of SPE International Ltd.



SPE International Limited
 Honeyholes Lane, Dunholme
 Lincoln, LN2 3SU, England
 Tel: +44 (0) 1673 860 709
 or +44 (0) 1673 860 330
 Fax: +44 (0) 1673 861 119
 Web Site: <http://www.spe-int.com>
 E-mail: sales@spe-int.com

THIS DRAWING IS THE CONFIDENTIAL COPYRIGHT PROPERTY OF SPE INTERNATIONAL LIMITED

Drawn	TITLE		Drum c/w Beam Flais
D.G.A.			
Checked	Drawing No.	MACHINE	
R.C.	BEF-200_Drum-BF	BEF 200	

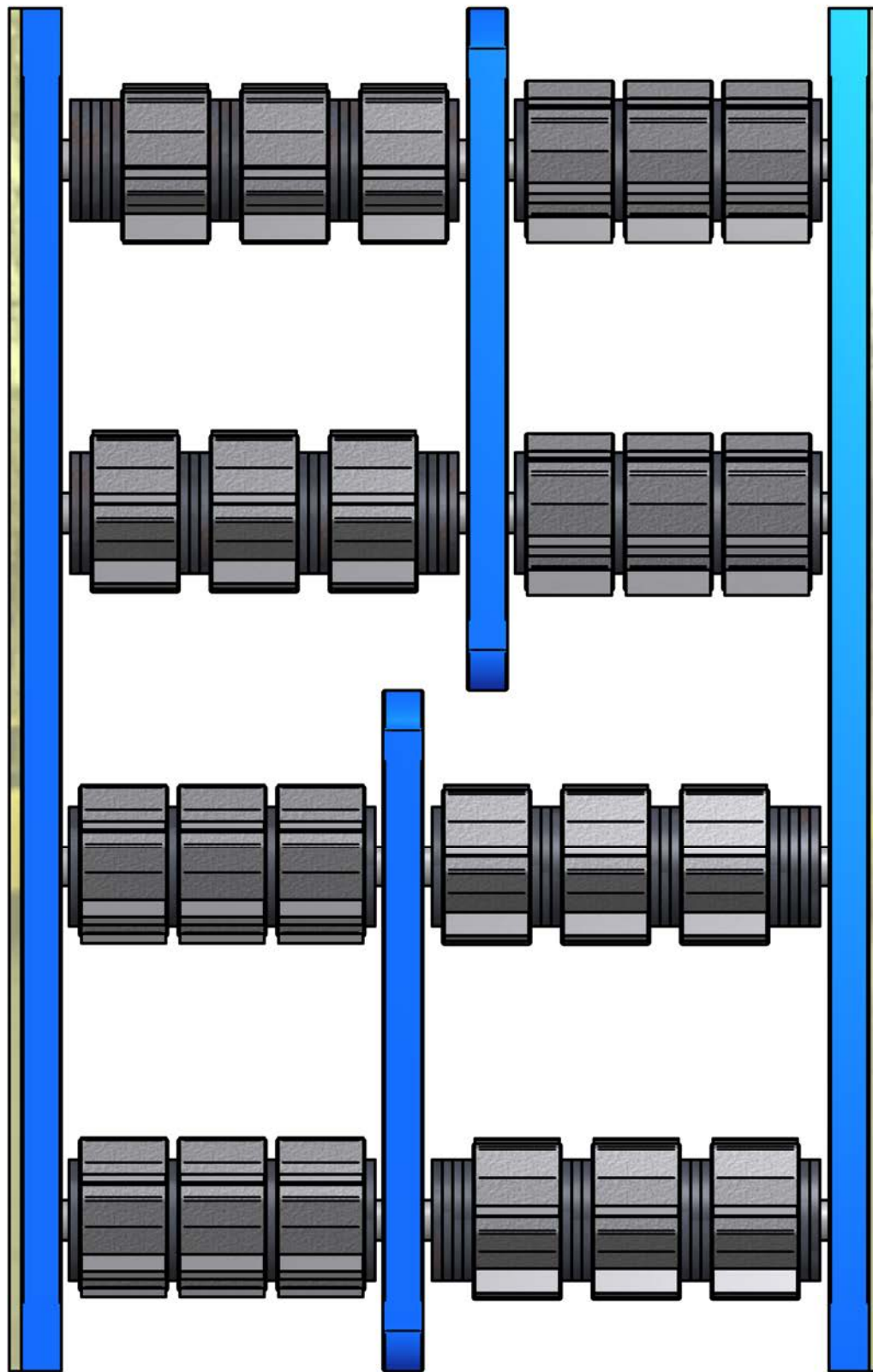

Parts List

QTY	SPE PART NUMBER	DESCRIPTION
64	24140	Spacer
24	45600	Milling cutter

This drawing should not be used, copied, shown or handed to a third party without the prior written consent of SPE International Ltd.



SPE International Limited
Honeyholes Lane, Dunholme
Lincoln, LN2 3SU, England
Tel: +44 (0) 1673 860 709
or +44 (0) 1673 860 330
Fax: +44 (0) 1673 861 119
Web Site: <http://www.spe-int.com>
E-mail: sales@spe-int.com

THIS DRAWING IS THE CONFIDENTIAL COPYRIGHT PROPERTY OF SPE INTERNATIONAL LIMITED

Drawn	TITLE		Drum c/w MCs
D.G.A.			
Checked	Drawing No.	MACHINE	
R.C.	BEF-200_Drum-MC	BEF 200	

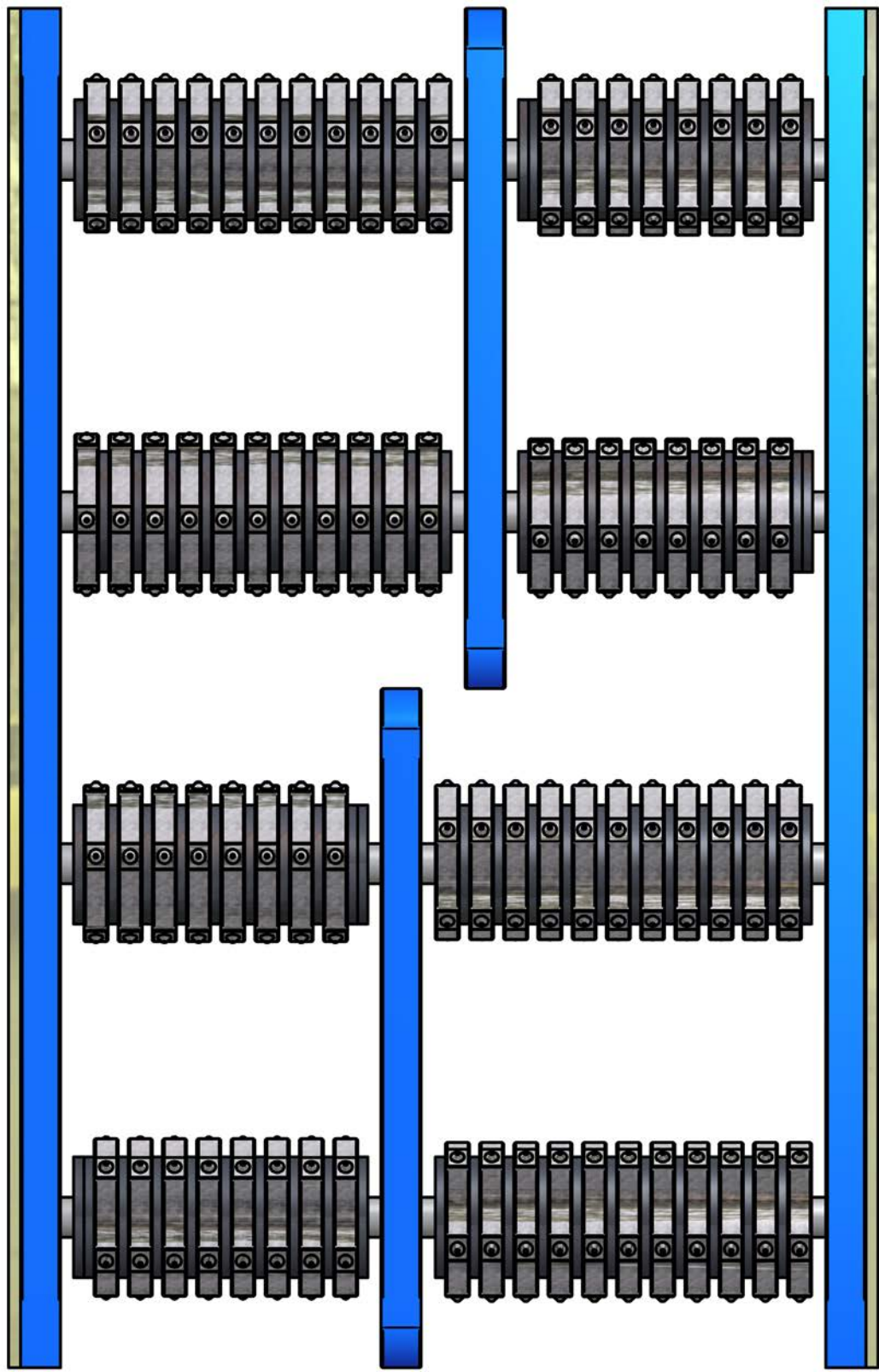

Parts List

QTY	SPE PART NUMBER	DESCRIPTION
84	24140	Spacer
76	45500	TCT Cutter

This drawing should not be used, copied, shown or handed to a third party without the prior written consent of SPE International Ltd.

Surface Preparation Equipment™

SPE International Limited
 Honeyholes Lane, Dunholme
 Lincoln, LN2 3SU, England
 Tel: +44 (0) 1673 860 709
 or +44 (0) 1673 860 330
 Fax: +44 (0) 1673 861 119
 Web Site: <http://www.spe-int.com>
 E-mail: sales@spe-int.com

THIS DRAWING IS THE CONFIDENTIAL COPYRIGHT PROPERTY OF SPE INTERNATIONAL LIMITED

Drawn	TITLE		Drum c/w TCTs
D.G.A.			
Checked	Drawing No.	MACHINE	
R.C.	BEF-200_Drum-TCT	BEF 200	



BEF200-1
Operating Manual

Spare Parts Breakdown

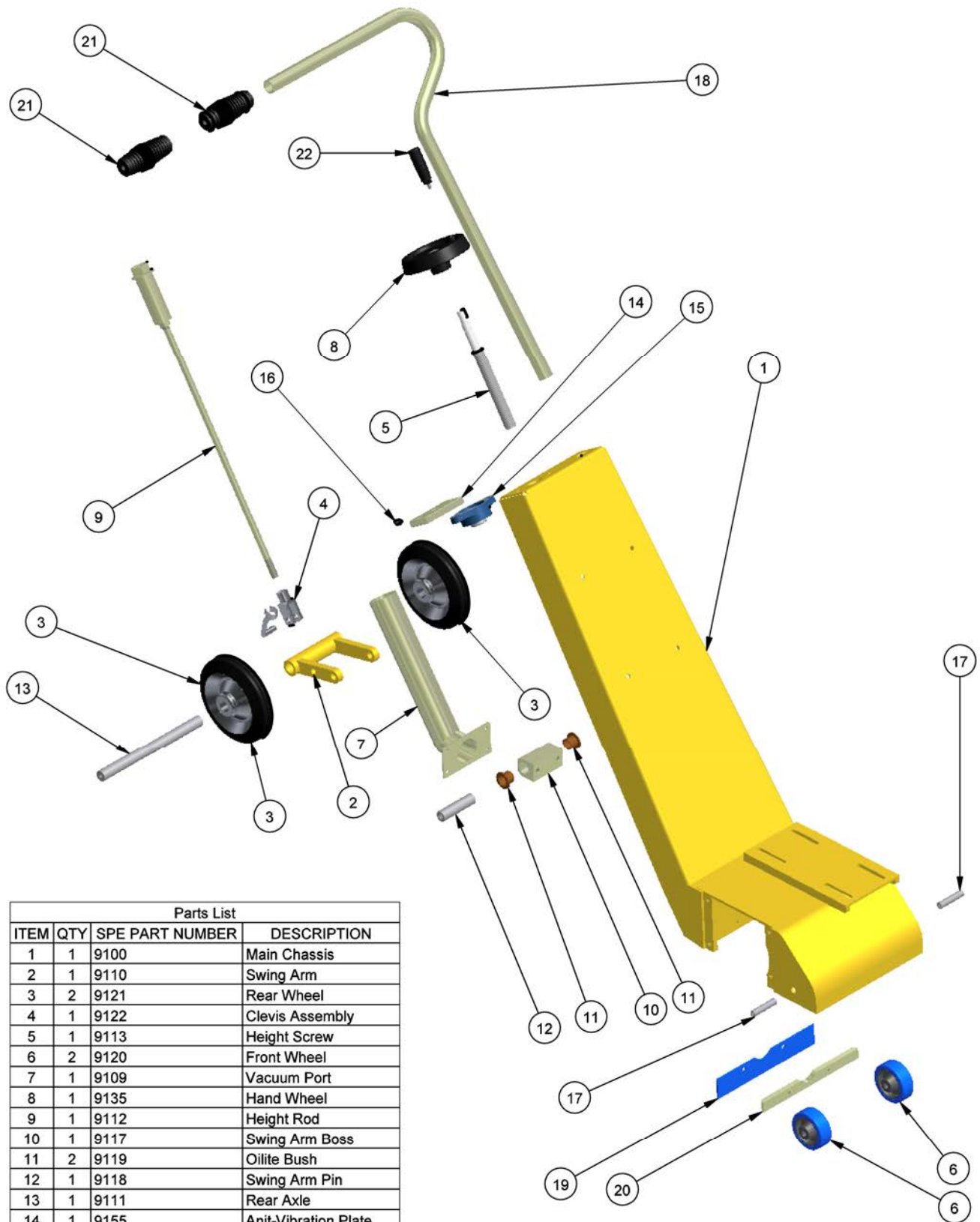

Parts List			
ITEM	QTY	SPE PART NUMBER	DESCRIPTION
1	1	9100	Main Chassis
2	1	9110	Swing Arm
3	2	9121	Rear Wheel
4	1	9122	Clevis Assembly
5	1	9113	Height Screw
6	2	9120	Front Wheel
7	1	9109	Vacuum Port
8	1	9135	Hand Wheel
9	1	9112	Height Rod
10	1	9117	Swing Arm Boss
11	2	9119	Oilite Bush
12	1	9118	Swing Arm Pin
13	1	9111	Rear Axle
14	1	9155	Anit-Vibration Plate
15	1	9134	Flange Bearing
16	1	9156	Anti Vibration Screw
17	2	9107	Front Axle
18	1	9103	Handlebar
19	1	9106	Dust Skirt
20	1	9105	Wear Strip
21	2	9104	Handlebar Grip
22	1	9136	Knob

This drawing should not be used, copied, shown or handed to a third party without the prior written consent of SPE International Ltd.



SPE International Limited
 Honeyholes Lane, Dunholme
 Lincoln, LN2 3SU, England
 Tel: +44 (0) 1673 860 709
 or +44 (0) 1673 860 330
 Fax: +44 (0) 1673 861 119
 Web Site: <http://www.spe-int.com>
 E-mail: sales@spe-int.com

**THIS DRAWING IS THE CONFIDENTIAL COPYRIGHT
 PROPERTY OF SPE INTERNATIONAL LIMITED**

Drawn	TITLE	Body Components
D.G.A.		
Checked	Drawing No.	MACHINE
P.A/R.C	BEF-200_Bdy-01	BEF 200-1

Parts List				Parts List			
ITEM	QTY	SPE PART NUMBER	DESCRIPTION	ITEM	QTY	SPE PART NUMBER	DESCRIPTION
1	1	9116	D/S Bearing Housing	15	1	9125	D/S Spacer
2	1	9148R	Mounting Rail Rear	16	1	9140	Drive Shaft
3	1	9148F	Mounting Rail Front	17	1	9128	Driven Pulley
4	1	9142	Electric Motor	18	1	9101	Side Plate
5	1	9130	8x35 Parallel Key	19	1	9115	S/P Bearing Housing
6	1	SP630-304	Surface Mounted Plug	20	1	9102	S/P Spacer
7	1	9143A	Electrical Panel Assembly	21	1	9123	S/P Bearing
8	4	9245	Flexible Mounts	22	1	9114	Driven Bush
9	1	9138	Belt Guard	23	1	9133	Ext. Circlip
10	4	20010	Flail Shaft	25	1	9127	Electric Motor Pulley
11	2	200EP	End Plate	26	1	9137	Drive Belt
12	1	20000	Complete Drum	27	4	9149	T Bolt
13	2	9132	Int. Circlip	28	2	9150	Spacer Plate
14	2	9124	D/S Bearing	29	1	9131	8x30 Parallel Key

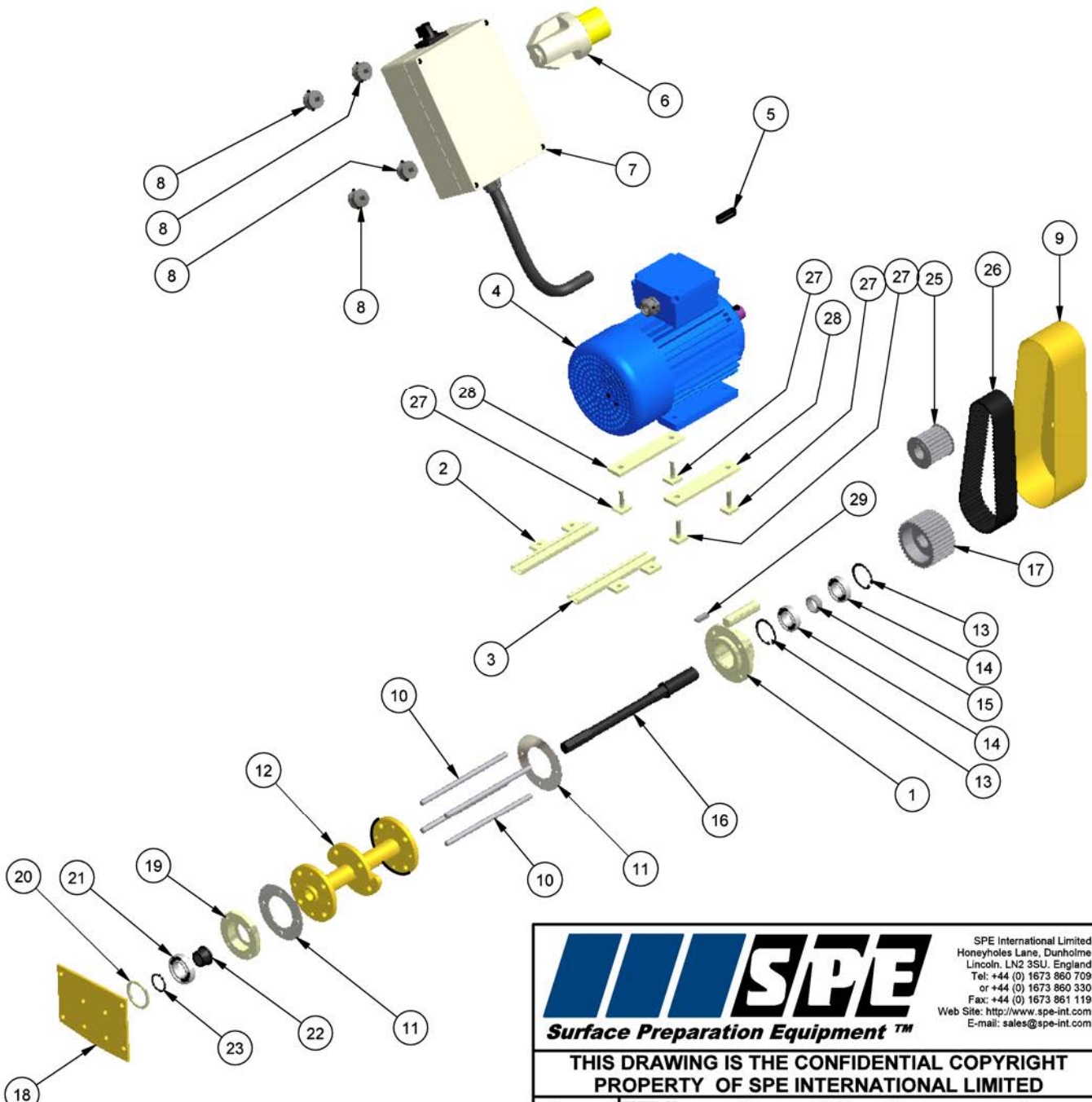

This drawing should not be used, copied, shown or handed to a third party without the prior written consent of SPE International Ltd.

SPE
Surface Preparation Equipment™

SPE International Limited
Honeyholes Lane, Dunholme
Lincoln, LN2 3SU, England
Tel: +44 (0) 1673 860 709
or +44 (0) 1673 860 330
Fax: +44 (0) 1673 861 119
Web Site: <http://www.spe-int.com>
E-mail: sales@spe-int.com

THIS DRAWING IS THE CONFIDENTIAL COPYRIGHT PROPERTY OF SPE INTERNATIONAL LIMITED

Drawn	TITLE		Drum Drive Components
D.G.A.			
Checked	Drawing No.	MACHINE	
u/c	BEF-200_DDr-01	BEF 200-1	

This drawing should not be used, copied, shown or handed to a third party without the prior written consent of SPE International Ltd.

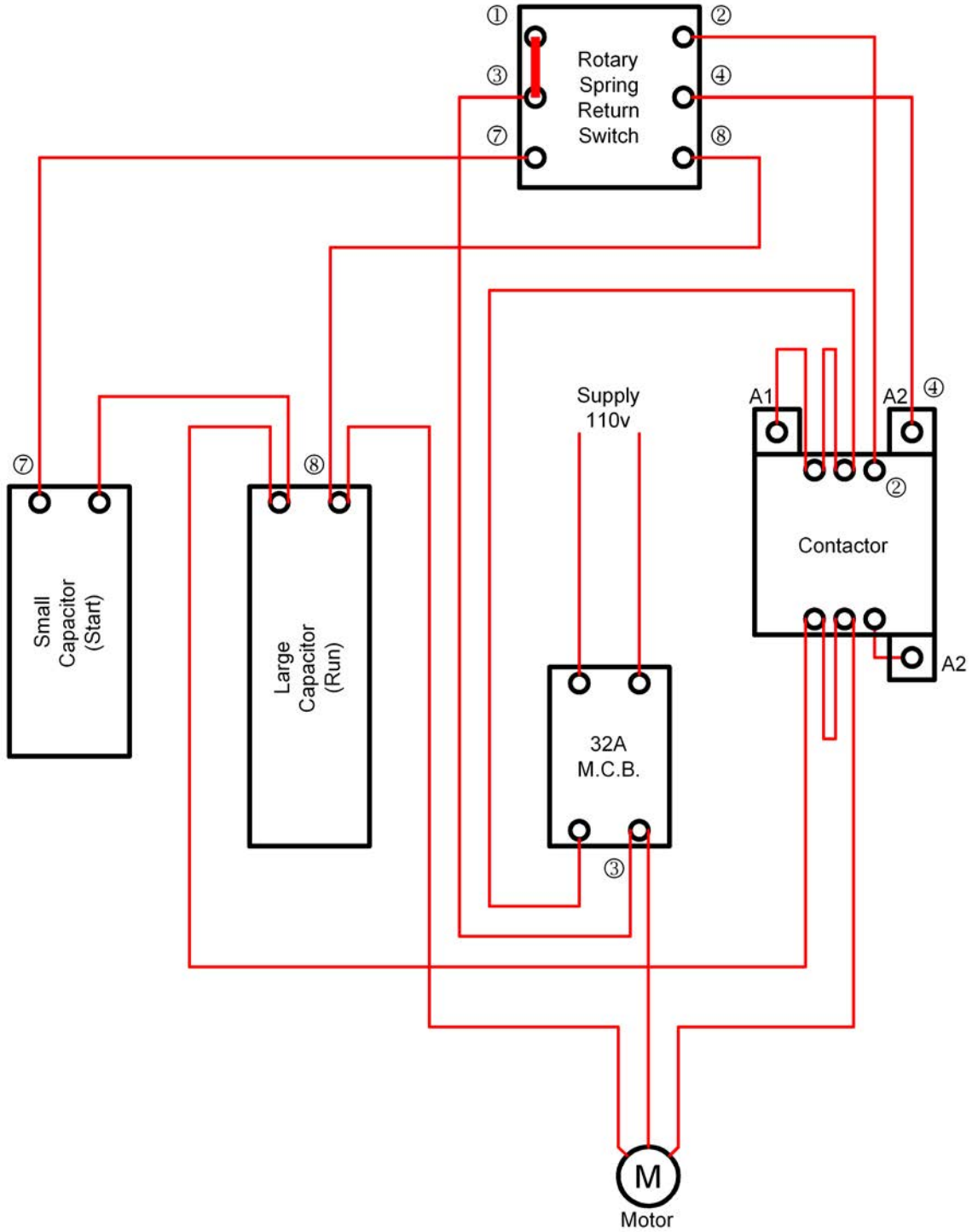

SPE
Surface Preparation Equipment™

SPE International Limited
Honeyholes Lane, Dunholme
Lincoln, LN2 3SU, England
Tel: +44 (0) 1673 860 709
or +44 (0) 1673 860 330
Fax: +44 (0) 1673 861 119
Web Site: www.spe-int.com
E-mail: sales@spe-int.com

THIS DRAWING IS THE CONFIDENTIAL COPYRIGHT PROPERTY OF SPE INTERNATIONAL Ltd.

Drawn	TITLE		Machine
D.G.A.	Wiring Diagram		
Checked	Drawing No.	BEF-200_Elec-01	BEF 200-1
J.J.			



BEF200-1 Operating Manual

ELECTRICAL COMPONENTS

QTY	DESCRIPTION	SPE PART NO
1	Panel box	SP2518-11
1	Hinge kit	SP190005
1	Back plate	9249
1	Rotary switch	9254-1
1	Contactator	9255
1	Contact breaker	9256
1	Plug retaining plate	9250
1	Start capacitor	156MF@240V
1	Run capacitor	70MF@450V
2	Conduit gland	9258
1	Conduit (MTR)	9259



BEF60 GENERAL OPERATION

The BEF60 is an optional accessory for the BEF200 Multiplane range.

This attachment is designed for preparing edge work against walls and pillars etc. The cutter drum used with the BEF60 has a 60mm cutting width and can be fitted with a selection of cutters.

1. Before attempting to fit the BEF60 isolate the power supply.
2. Remove the 4no 8mm set screws securing the side plate on the BEF200 and remove the side plate. (Part No 9101)
3. Remove the cutter drum from the BEF200 machine.
4. Check the BEF60 unit, cutter drum, cutters etc and ensure all nuts/bolts are tight.
5. Fit the BEF60 to the BEF200 in replacement of the side plate. You may need to turn the drive bush to ensure the unit slides smoothly onto the BEF200 drive shaft.
6. Refit the 4no 8mm set screws and tighten.
7. Fit vacuum hose to the BEF60 dust port if using a dust control vacuum.



BEF200-1
Operating Manual

BEF60

SPARE PARTS BREAKDOWN

Parts List

ITEM	QTY	SPE PART NUMBER	DESCRIPTION
1	1	9260	Chassis
2	1	9276	Drum c/w F/Shafts and E/Plate
3	4	9279	Flail Shaft
4	1	9277	End plate
5	1	9267	Bearing Housing (Int)
6	3	9123	Bearing
7	2	9114	Hexagonal Drive Bush
8	1	9272	Long Hexagonal Support
9	3	9133	Circlip - External
10	2	9268	Circlip - Internal
11	1	9263	Shaft
12	1	9266	SCKT. HD. Screw M6x25
13	1	9271	Bearing Housing (Ext)
14	1	9294	Securing Washer
15	1	9265	CSK. Screw
16	1	9261	Cover Plate
17	2	9275	Dust Skirt
18	2	9273	Retaining Bar

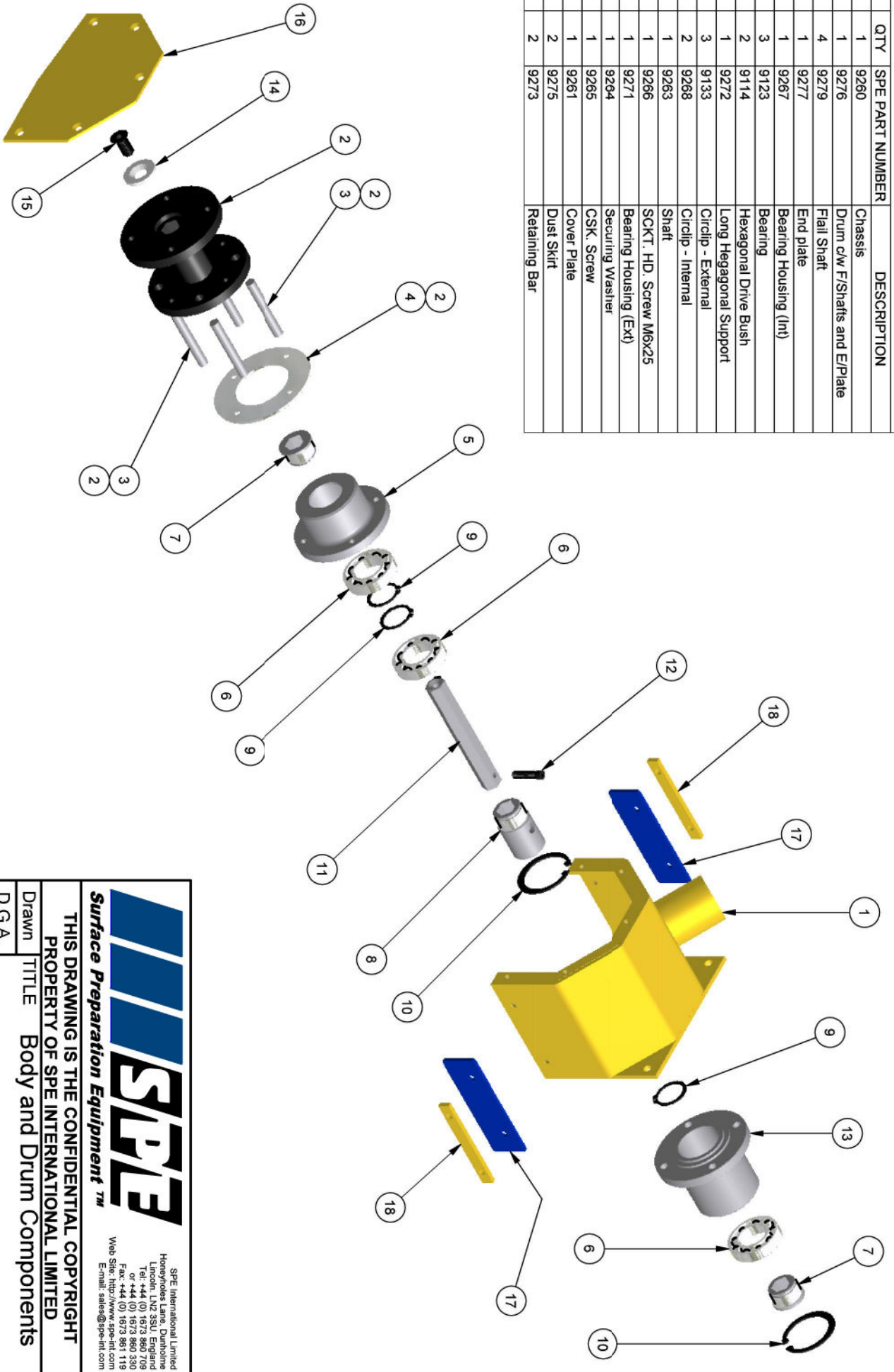

This drawing should not be used, copied, shown or handed to a third party without the prior written consent of SPE International Ltd.

SPE International Limited
 Honeyrobes Lane, Dunholme
 Lincoln, LN2 3SL, England
 Tel: +44 (0) 1673 860 706
 or +44 (0) 1673 860 330
 Fax: +44 (0) 1673 861 118
 Web Site: www.spe-int.com
 E-mail: sales@spe-int.com

THIS DRAWING IS THE CONFIDENTIAL COPYRIGHT PROPERTY OF SPE INTERNATIONAL LIMITED

Surface Preparation Equipment™

TITLE Body and Drum Components

Drawn **D.G.A.**

Checked **P.A.**

Drawing No. **BEF-60_BdD-01**

MACHINE **BEF 60**



BEF200-1
Operating Manual

SPECIFICATION SHEET

Specifications	
Type	Electric 1 Phase
Part Number	BEF200-1 (110v)
Power Output	3hp
Air Input	-
Voltage	110
Cycles	50hz
Cutter Head Speed (rpm)	1753
Machine Dimensions (mm)	
Length	940
Width	340
Height	905
Weight (kg)	54
Working width of cutters (mm)	200
Working distance from wall (mm)	45
Working distance from wall with edger attachment (mm)	5-8
Motor speed (rpm)	2870

ELECTRICAL REQUIREMENTS

Volts	Plug Size	Cable Size	Max Cable Length	Transformer	Generator
110	32 Amp 3 pin	4.0 - 3 core	30 metres	5kva	8 kva



BEF200-1
Operating Manual

RECORD OF NOISE AND VIBRATION ASSESSMENT

Manufacturer:	SPE
Type:	Scarifier
Model No.	BEF200-1 Electric
Operation:	Concrete floor surface
Inserted Tool:	TCT cutters
Running Conditions:	2870 rpm
HAV Note:	Operc

HAND-ARM VIBRATION

Frequency Weighted Energy Equivalent Accelerations ($a_{h,w}$)

Measurement Position	Acceleration (m/s^2)
	Vector Sum
Handle	4.4

NOISE LEVELS

Sound Power Level (L_{WA})

L_{WA} at Octave Band Centre Frequency (Hz)								Sound Power Level L_{WA}
63	125	250	500	1000	2000	4000	8000	
46.7	61.0	81.9	86.9	90.3	91.7	91.3	84.0	96.8

Operator's Ear

$L_{Aeq,T}$ at Octave Band Centre Frequency (Hz)								Overall Level ($L_{Aeq,T}$)	L_{Peak} dB(C)
63	125	250	500	1000	2000	4000	8000		
32.1	44.1	67	75.6	79.4	77.5	75.6	67.5	84.2	99.8





BEF200-1
Operating Manual

RECORD OF NOISE AND VIBRATION ASSESSMENT

Manufacturer:	SPE
Type:	Scarifier
Model No.	BEF200-1 Electric
Operation:	Concrete floor surface
Inserted Tool:	Beam cutters
Running Conditions:	2870 rpm
HAV Note:	Operc

HAND-ARM VIBRATION

Frequency Weighted Energy Equivalent Accelerations ($a_{h,w}$)

Measurement Position	Acceleration (m/s^2)
	Vector Sum
Handle	3.9

NOISE LEVELS

Sound Power Level (L_{WA})

L_{WA} at Octave Band Centre Frequency (Hz)								Sound Power Level L_{WA}
63	125	250	500	1000	2000	4000	8000	
46.7	61.0	81.9	86.9	90.3	91.7	91.3	84.0	96.8

Operator's Ear

$L_{Aeq,T}$ at Octave Band Centre Frequency (Hz)								Overall Level ($L_{Aeq,T}$)	L_{Peak} dB(C)
63	125	250	500	1000	2000	4000	8000		
32.1	44.1	67	75.6	79.4	77.5	75.6	67.5	84.2	99.8





BEF200-1 Operating Manual

WARRANTY

The standard warranty period of this equipment is **12 months** from the date below in accordance with the company Conditions of Sale (copy attached).

<i>Warranty start date:</i>	As despatch date
<i>Model:</i>	BEF200-1
<i>Serial no:</i>	
<i>Customer name:</i>	
<i>Customer Address:</i>	

<i>Manufacturer:</i>	SPE International Ltd
	Honeyholes Lane
	Dunholme
	Lincoln
	LN2 3SU
	England
<i>Telephone:</i>	+44 (0) 1673 860709
<i>Fax:</i>	+44 (0) 1673 861119
<i>Email:</i>	<u>sales@spe-int.com</u>
<i>Web site:</i>	<u>www.spe-int.com</u>



BEF200-1
Operating Manual

DECLARATION OF CONFORMITY

WE
SPE INTERNATIONAL LTD

OF
Honeyholes Lane
Dunholme
Lincoln
LN2 3SU

DECLARE that under our sole responsibility for the supply/manufacture of the product

(Description/name) **BEF200 Multiplane**

(Model/type) **BEF200-1**

to which this declaration relates is in conformity with the following standards and other normative documents following the provisions of Directive 2006/42/EC.

A handwritten signature in black ink, appearing to read 'B. Jacklin', is positioned above the printed name.

.....
Brian Jacklin – Technical Manager
SPE INTERNATIONAL LTD



CONDITIONS OF SALE

BEF200-1 Operating Manual

The quotation overleaf and any order placed following such quotation are subject to the following conditions of sale in which SPE International Limited is referred to as the "Company".

1. **Validity of quotation**
No order received from a customer by the Company shall constitute a contract until accepted in writing by the Company.
2. **Prices**
Prices quoted by the Company are firm for 30 days only or until previously withdrawn. Unless otherwise stated all prices are exclusive of any applicable Value Added Tax for which the customer shall be additionally liable to the Company.
3. **Delivery**
Delivery periods and dates are given in good faith but are not the subject of any warranty or condition and time shall not be of the essence of the contract in these respects. No liability will attach to the Company if delivery periods or dates are not met for any reason whatsoever.
4. **Payment**
Save as may otherwise be agreed in writing the customer shall pay the price in full on or before the estimated delivery date whereupon the Company shall raise a receipted invoice. Each invoice includes an Overdue Account Levy of 5% of the total invoice value inclusive of VAT. Subject to payment in full being made on or before the due date a sum equal to the Overdue Account Levy shall be credited to the customer's account with the Company. Until such time as payment in full has been made the Company shall be under no obligation to allow or effect of any goods to the customer.
5. **Warranty**
The Company warrants that all goods supplied by it will correspond to their specifications and will be free from defects in materials or workmanship for a period of 12 months from the date of delivery. The Company's obligation in the event of a breach of this warranty is limited to the repair or replacement of any defective goods which shall be returned at the cost and expense of the customer to the Company. This warranty is given in lieu of all the other warranty or conditions expressed or implied (whether by statute or otherwise) and is subject to the following conditions:-
 - 5.1 Claims must be notified in writing to the Company within seven days from the date of delivery or (where the defect is not apparent on reasonable inspection) as soon as practicable after discovery of the defect.
 - 5.2 The Company shall be under no liability in respect of any defect in the goods arising from any drawing, design or specification supplied by the customer.
 - 5.3 The Company shall be under no liability if the defect or failure in the reasonable opinion of the Company arises from wilful damage or misuse, negligence by the customer or any third party. Failure to follow the Company instructions, usage of non-recommended parts and materials, alteration or repair of the goods without the prior approval of the Company or non-recommended maintenance.
 - 5.4 The Company shall be under no liability if the price for the goods has not been paid by the due date for payment.
 - 5.5 The above warranty does not extend to:-
 - 5.5.1 Parts, materials or equipment not manufactured by the company in respect of which the customer shall be entitled only to the benefit of any such warranty or guarantee as is given by the manufacturer to the Company.
 - 5.5.2 Any component part of the goods or associated parts coming into contact with abrasive elements or dust within surface Preparation equipment.
 - 5.5.3 Fair wear and tear of moving parts within the goods.
 - 5.6 Except in the case of death or personal injury caused by the Company negligence, the Company shall not be liable for any consequential loss or damage (whether for loss of profit or otherwise) or other claims for consequential compensation.
6. **Carriage**
Packing, carriage and insurance charges in respect of delivery of the goods to the customer will be charged to the customer at cost to the company.
7. **Damage in Transit**
The company does not accept any liability for loss or damage to the goods while in transit to the customer.
8. **Risk**
The risk in the goods shall pass to the customer on delivery to the customer or (if earlier) when possession of the goods is taken by a carrier for delivery to the customer.
9. **Force Majeure**
The Company shall not be liable to the customer or be deemed to be in breach of any contract with the customer by reason of any delay in performing or any failure to perform any obligation of the Company obligation in relation to the goods if the delay or failure was due to force majeure or to any other cause beyond the Company's reasonable control.
10. **Reservation of Title**
The goods sold under these conditions shall remain the absolute property of the Company and legal title in the goods shall remain vested in the Company until payment in full of all amounts invoiced or due to the Company in respect of the goods. If the customer shall enter into liquidation have a winding up order made against it or have a Liquidator, receiver, administrator or administrator receiver shall be appointed over its assets, income or any part thereof before the property in the goods has passed in accordance with this condition the Company shall be entitled immediately after giving notice of its intention to repossess any goods to enter upon the premises of the customer with such transport as may be necessary and to repossess any goods to which it has title under this condition. No liquidator, receiver, administrator or administrative receiver of the customer shall have authority to sell goods to which the Company has title without the prior written consent of the Company.
11. **Insolvency of Customer**
If the customer being a body corporate, shall pass a resolution or suffer an order of the Court to be made for winding – up, or if a Receiver, Administrator or Administrative Receiver shall be appointed or, being an individual or partnership, shall suspend payment, propose or enter into any composition or arrangement with his or their creditors, or have a bankruptcy order made against him or them, then the Company shall have the right, without prejudice to any other contract with the customer, not to proceed further with the contract and shall be entitled to charge for work already carried out (whether completed or not) and for goods and materials already purchased for the customer such charge to be an immediate debt due from the customer.
12. **Patent Rights, etc**
The acceptance of a quotation includes the recognition by the customer of the Company under any patents, trademarks, registered designs or other intellectual property rights relating to the goods and the customer undertakes that patent numbers, trademarks or other trade markings on goods supplied shall not be obliterated, altered or defaced.
13. **Applicable Law**
These conditions shall be governed by and construed in accordance with English law and parties acknowledge and accept the exclusive jurisdiction of the English Courts.