



Operation & Maintenance Manual

7/26E, 7/31E, 7/41, 7/51

7/26E Serial No.: 107000 ->

7/41 Serial No.: 421500 ->

7/31E Serial No.: 318000 ->

7/51 Serial No.: 442000 ->



This manual contains important safety information.

Do not destroy this manual.

This manual must be available to the personnel who operate and maintain this machine.

Doosan purchased Bobcat Company from Ingersoll-Rand Company in 2007. Any reference to Ingersoll-Rand Company or use of trademarks, service marks, logos, or other proprietary identifying marks belonging to Ingersoll-Rand Company in this manual is historical or nominative in nature, and is not meant to suggest a current affiliation between Ingersoll-Rand Company and Doosan Company or the products of either.

Utility Equipment
P.O. Box 868 - 501 Sanford Ave
Mocksville, N.C. 27028

Book: 22221949 (12-15-06) Rev. A

Revised (10-12)

TABLE OF CONTENTS

Operation & Maintenance Manual

TITLE	PAGE
FOREWORD	9
WARRANTY	13
General Warranty Information - ESA	17
Extended Limited Aired Warranty	19
Warranty Registration	20
Complete Machine Registration	20
Engine Registration	20
Complete Machine Registration	21
Engine Registration	21
Portable Power	22
DECALS	23
NOISE EMISSION	31
Compressor Noise Emission Control Information	32
Noise Emission Control Maintenance Log	33
Noise Emission Warranty	33
Introduction	33
Maintenance Schedule	34
Compressed Air Leaks	34
Safety and Control Systems	34
Acoustic Materials	34
Fasteners	34
Enclosure Panels	35
Air Intake and Engine Exhaust	35
Cooling Systems	35
Isolation Mounts	35
Engine Operation	35
Fuels and Lubricants	35
SAFETY	37
General Information	38
Compressed Air	39
Materials	40
Battery	41
Radiator	41
Generator Sets	41
Emergency Stop Controls	42
Transport	43
Safety Chains/Connections and their Adjustment	44

TABLE OF CONTENTS

Operation & Maintenance Manual

TITLE	PAGE
GENERAL INFORMATION	45
Compressor	50
Lubricating Oil Specification	51
Engine 7/26E	51
Engine 7/31E	52
Engine 7/41	52
Engine 7/51	52
Sound Level Data ('W' Model)	53
Fixed Height Running Gear - 7/26E, 7/31E	53
Variable Height Running Gear - 7/26E, 7/31E	53
Fixed Height Running Gear - 7/41, 7/51	54
Variable Height Running Gear - 7/41, 7/51	54
Wheels and Tyres (Knott)	54
 OPERATING INSTRUCTIONS	 55
Commissioning	56
Prior to Starting	58
Starting the Machine	60
Push After Warm Up - When Fitted 7/26E, 7/31E, 7/41, 7/51 - Optional	61
Dual Pressure When Fitted	61
Stopping the Machine	62
Emergency Stopping	62
Re-Starting After an Emergency	62
Monitoring During Operation	63
Decommissioning	63
 MAINTENANCE	 65
Maintenance Schedule	66
Routine Maintenance	69
Protective Shutdown System	70
Low Engine Oil Pressure Switch	71
Temperature Switch (ES)	71
High Discharge Air Temperature Switch (ES)	71
High Water Temperature Switch	71
Alternator/Drive Belt Failure Circuit	72
Low Engine Fuel Level Switch	72
Scavenge Line	72
Compressor Oil Filter	73
Removal	73
Inspection	73
Reassembly	73
Compressor Oil Separator Element	74
Removal	74
Inspection	74
Reassembly	74
Compressor Oil Cooler and Engine Radiator	75
Air Filter Elements	76
Removal	76
Inspection	76

TABLE OF CONTENTS

Operation & Maintenance Manual

TITLE	PAGE
Reassembly	76
Ventilation	76
Cooling Fan Drive	77
Fuel System	77
Fuel Filter Water Separator	77
Hoses	77
Electrical System	77
Battery	78
Pressure System	78
Tyres/Tyre Pressure	78
Running Gear/Wheels	78
Brakes	79
Adjusting the Overrun Braking System (Knott Running Gear)	79
Preparation	79
Brake Shoe Adjustment	80
Compensator Assembly Adjustment	81
Brake Linkage Adjustment	81
Re-adjusting the Overrun Braking System (Knott Running Gear)	82
Re-adjustment	82
Final test	83
Lubrication	83
Engine Lubricating Oil	83
Engine Lubricating Oil Specification	83
Engine Oil Filter Element	83
Compressor Lubricating Oil	84
Compressor Oil Filter Element	84
Running Gear Wheel Bearings	85
Speed and Pressure Regulation Adjustment	85
Torque Values	86
Compressor Lubrication	87
Portable Compressor Fluid Chart	87
ELECTRICAL SYSTEM	89
PIPING AND INSTRUMENTATION SYSTEM	99
FAULT FINDING	101
OPTIONS	105
Lubricator	106
Safety	106
General Information	106
Operating Instructions	106
Commissioning	106
Prior to Starting	106
Maintenance	106
Fault Finding	106
Generator (WDG)	107

TABLE OF CONTENTS

Operation & Maintenance Manual

TITLE	PAGE
Safety	107
General Information	107
Operating Instructions	108
Prior to Starting (Generator) (WDG).	108
Starting the Machine.	109
Stopping the Machine.	110
Emergency Stopping	110
Re-Starting After an Emergency.	110
Monitoring During Operation	110
Decommissioning	111
Maintenance	111
General.	111
Earth Leakage Circuit Breaker (ELCB).	111
Instruments and Controls	111
Fault Finding	112
A.C. Electrical Power Schematic Diagram, 115V 1 - Phase	114
A.C. Electrical Power Schematic Diagram, 230V 1 - Phase.	115
A.C. Electrical Power Schematic Diagram, 400/230V 3 - Phase	116
ENGINE.	117
Foreword.	118
Diesel Engine	119
General Information	120
EPA Certified Engine Data and Specifications - 3IRH2N.	120
Engine Identification	121
EPA Certified Engine Data and Specifications - 3IRH8N.	122
Engine Identification	123
EPA Certified Engine Data and Specifications - 4IRH8N.	124
Engine Identification	125
EPA Certified Engine Data and Specifications - 4IRI8N.	126
Engine Identification	127
Emission Control Label	128
Engine Label (for EPA).	128
Engine Label (for 4IRL5N)	129
Fuel, Lubricants and Coolant	130
Fuel.	130
Fuel Selection.	130
Fuel Requirements	130
Handling of the Fuel	131
Water in Fuel	132
Biocides	132
Smoke Suppressants	132
Lubricant.	133
Coolant.	134
Engine Operation	135
Check Before Operation.	135
Engine Oil Level	135
Fan Belt Check	136
Coolant Level Check	137
Radiator Cap Condition	137
Battery Cable Connection.	137
Battery Electrolyte Level.	138
Fuel Level.	138

TABLE OF CONTENTS

Operation & Maintenance Manual

TITLE	PAGE
Checks and Operation after Start-Up	139
Check After the Engine Start-Up	139
Checking Coolant Level	139
Operation and Care of a New Engine.....	140
Overheating	140
Overcooling	141
Engine Stopping	142
Long Term Storage.....	142
Engine Maintenance Schedule	143
Periodical Inspection and Maintenance	144
Inspection after Initial 50 Hours Operation	144
Replacing the Engine Oil and Engine Oil Filter (1st time)	144
Checking and Adjusting Cooling Fan V-Belt.....	146
Use of Genuine Ingersoll Rand Fan Belt	147
Inspection Every 50 Hours Operation.....	148
Draining of the Fuel Tank (NOT 7/26E, 7/31E)	148
Draining of the Oil/Water Separator	148
Inspection of Battery.....	149
Inspection Every 250 Hours Operation.....	151
Replacing the Engine Oil and Engine Oil Filter (2nd time and after)	151
Checking and Cleaning Radiator Fins.....	151
Checking the Governor Lever and Accelerating Device.....	151
Replacing Fuel Filter.....	152
Changing Oil/Water Separator Element.....	152
Air Intake System	153
Air Cleaner	153
Air Cleaner with Dust Indicator	154
Inspection Every 500 Hours Operation.....	154
Replacing the Air Cleaner Element	154
Inspection Every 1000 Hours Operation.....	154
Replacing Cooling Water	154
Checking and Adjusting the Fuel Injection Valve	154
Adjusting Intake/Exhaust Valve Clearance.....	155
Inspection Every 2000 Hours Operation.....	155
Flushing the Cooling System & Checking the Cooling System Parts.....	155
Checking and Replacing Fuel Hoses and Cooling Water Hoses	155
Lapping the Intake and Exhaust Valves	155
Checking and Adjusting the Fuel Injection Timing	155
Engine Maintenance Schedule	156
Explanation of Maintenance Schedule	156
Engine Troubleshooting	157

*****Always use Ingersoll Rand Replacement parts!*****



Foreword

Foreword

The contents of this manual are considered to be proprietary and confidential to Ingersoll Rand and should not be reproduced without the prior written permission of Ingersoll Rand.

Nothing contained in this document is intended to extend any promise, warranty or representation, expressed or implied, regarding the Ingersoll Rand products described herein. Any such warranties or other terms and conditions of sale of products shall be in accordance with the standard terms and conditions of sale for such products, which are available upon request.

This manual contains instructions and technical data to cover all routine operation and scheduled maintenance tasks by operation and maintenance staff. Major overhauls are outside the scope of this manual and should be referred to an authorised Ingersoll Rand service department.

The design specification of this machine has been certified as complying with EC directives. As a result:

- a. Any machine modifications are strictly prohibited, and will invalidate EC certification.
- b. A unique specification for USA/Canada is adopted and tailored to the territory.

All components, accessories, pipes and connectors added to the compressed air system should be:

- of good quality, procured from a reputable manufacturer and, wherever possible, be of a type approved by Ingersoll Rand.
- clearly rated for a pressure at least equal to the machine maximum allowable working pressure.
- compatible with the compressor lubricant/coolant.
- accompanied with instructions for safe installation, operation and maintenance.

Details of approved equipment are available from Ingersoll Rand Service departments.

The use of repair parts/lubricants/fluids other than those included within the Ingersoll Rand approved parts list may create hazardous conditions over which Ingersoll Rand has no control. Therefore Ingersoll Rand cannot be held responsible for equipment in which non-approved repair parts are installed.

Ingersoll Rand reserves the right to make changes and improvements to products without notice and without incurring any obligation to make such changes or add such improvements to products sold previously.

The intended uses of this machine are outlined below and examples of unapproved usage are also given, however Ingersoll Rand cannot anticipate every application or work situation that may arise.

IF IN DOUBT CONSULT SUPERVISION.

This machine has been designed and supplied for use only in the following specified conditions and applications:

- Compression of normal ambient air containing no known or detectable additional gases, vapours. or particles
- Operation within the ambient temperature range specified in the “General Information” section of this manual.
- Generation of electricity at 110v (1ph) with centre tap earth, 230v (1ph), 230v (3ph) and 400v (3ph)/230v (1ph) nominal at 50 Hertz. (WDG)

The use of the machine in any of the situation types listed in table 1:-

- a. Is not approved by Ingersoll Rand,**
- b. May impair the safety of users and other persons, and**
- c. May prejudice any claims made against Ingersoll Rand.**

Table 1:

Use of the machine to produce compressed air for: <ul style="list-style-type: none"> a. direct human consumption b. indirect human consumption, without suitable filtration and purity checks.
Use of the machine outside the ambient temperature range specified in the “General Information” section of this manual.
This machine is not intended and must not be used in potentially explosive atmospheres, including situations where flammable gases or vapours may be present.
Use of the machine fitted with non Ingersoll Rand approved components/ lubricants/fluids.
Use of the machine with safety or control components missing or disabled.
Use of the machine for storage or transportation of materials inside or on the enclosure except when contained within the toolbox.
Generator
Use of the generator to supply load(s) greater than those specified.
Use of unsafe or unserviceable electrical equipment connected to the generator.
Use of electrical equipment: <ul style="list-style-type: none"> a. Having incorrect voltage and/or frequency ratings. b. Containing computer equipment and/or similar electronics.

The company accepts no responsibility for errors in translation of this manual from the original English version.

*****Always use Ingersoll Rand Replacement parts!*****



Warranty

Warranty

Ingersoll Rand, through its distributor, warrants that each item of equipment manufactured by it and delivered hereunder to the initial user will be free of defects in material and workmanship for a period of three (3) months from initial operation or six (6) months from the date of shipment to the initial user, whichever occurs first.

With respect to the following types of equipment, the warranty period enumerated below will apply in lieu of the foregoing warranty period.

A. **Aftercoolers** - The earlier of nine (9) months from date of shipment to or six (6) months from start up by initial user.

B. **Portable Compressors, Portable Generator Sets - 9 Kva through to 550 Kva, Portable Light Towers and Air Dryers** - The earlier of twelve (12) months from shipment to or the accumulation of 2,000 hours of service by the initial user.

2.5 Kva Through to 8 Kva - The earlier of twelve (12) months from shipment to or the accumulation of 2,000 hours of operation by the initial user.

Ingersoll Rand will provide a new part or repaired part, at its sole discretion, in place of any part which is found to be defective in material or workmanship during the period described above. Labor cost to replace the part is the responsibility of the initial user.

C. **Portable Compressor Air Ends** - The earlier of twenty-four (24) months from shipment to or the accumulation of 4,000 hours of service by the initial user. For Air Ends, the warranty against defects will include replacement of the complete Air End, provided the original Air End is returned assembled and all original seals are intact.

C1. **Portable Compressor Airend Limited Extended Warranty** - The earlier of sixty (60) months from shipment to or the accumulation of 10,000 hours of operation by the initial user. This extended warranty is limited to defects in design or defective material or workmanship in rotors, housings, bearings and gears and provided all the following conditions are met:

The original air end is returned assembled and all original seals are intact.

Continued use of genuine Ingersoll Rand parts, fluids, oils and filters.

Maintenance is performed at prescribed intervals by authorized and properly trained service engineers.

D. **Generator Alternator - 9 Kva through to 550 Kva** - The earlier of twenty-four (24) months from shipment to or the accumulation of 4,000 hours of operation by the initial user.

2.5 Kva Through to 8 Kva - The earlier of twelve (12) months from shipment to or the accumulation of 2,000 hours of operation by the initial user.

- E. **Portable Light Tower Alternator** - The earlier of twelve (12) months from shipment to or the accumulation of 2,000 hours of operation by the initial user. Light Source model only, the earlier of twenty-four (24) months from shipment to or the accumulation of 4,000 hours of operation by the initial user.
- F. **Ingersoll Rand Engines** - The earlier of twenty-four (24) months from shipment to or the accumulation of 4,000 hours of operation by the initial user.
- G. **Ingersoll Rand Platinum Drive Train Limited Extended Warranty** - Platinum drive train refers to the Ingersoll Rand Engine and Airend combination. The earlier of sixty (60) months from shipment to, or the accumulation of 10,000 hours of operation by the initial user. The starter, alternator, fuel injection system and all electrical components are excluded from this extended warranty. The airend seal and drive coupling are included in the warranty but airend drive belts are excluded. This limited extended warranty is automatically available when meeting the following conditions are met:
1. The original airend is returned assembled and unopened.
 2. Continued use of genuine Ingersoll Rand parts, fluids, oil and filters.
 3. Maintenance is performed at prescribed intervals by authorized and properly trained service engineers.

Ingersoll Rand shall be provided with such information as it requires to confirm that these conditions have been complied with.

- H1. **Construction Tools, (Portable Power range only)** - Twelve (12) months from shipment to initial user. Ingersoll Rand will provide a new part or repaired part, at it's sole discretion, in place of any part which is found to be defective in material or workmanship during the period described above. Labor cost to replace the part is the responsibility of the initial user.
- H2. **Construction Tools Limited Extended Warranty, (Portable Power range only)** - Thirty-six (36) months from shipment to initial user. This extended warranty is automatically available only when the tool is registered with Ingersoll Rand by completing and submitting the Warranty Registration form. Ingersoll Rand will provide a new part or repaired part, at it's sole discretion, in place of any part which is found to be defective in material or workmanship during the period described above. Labor cost to replace the part is the responsibility of the initial user.
- I. **Spare Parts** - Six (6) months from date of shipment to the initial user.

Ingersoll Rand will provide a new part or repaired part, at its sole discretion, in place of any part that is found to be defective in material and workmanship during the period described above. Such parts will be repaired or replaced without charge to the initial user during normal working hours at the place of business of an Ingersoll Rand distributor authorized to sell the type of equipment involved or other establishment authorized by Ingersoll Rand. User must present proof of purchase at the time of exercising warranty.

The above warranties do not apply to failures occurring as a result of abuse; misuse, negligent repairs, corrosion, erosion and normal wear and tear, alterations or modifications made to the product without express written consent of Ingersoll Rand; or failure to follow the recommended operating practices and maintenance procedures as provided in the product's operating and maintenance publications.

Accessories or equipment furnished by Ingersoll Rand, but manufactured by others, including, but not limited to, engines, tires, batteries, engine electrical equipment, hydraulic transmissions, carriers, shall carry only the manufacturers warranty, which Ingersoll Rand can lawfully assign to the initial user.

THE ABOVE WARRANTIES ARE IN LIEU OF ALL OTHER WARRANTIES EXPRESSED OR IMPLIED, (EXCEPT THAT OF TITLE), AND THERE ARE NO WARRANTIES OF MERCHANTABILITY OR OF FITNESS FOR A PARTICULAR PURPOSE.

General Warranty Information - ESA

			Comments
Portable Compressor	Package	12 Months/2,000 hours	Covers Controls, Switches, Sheet Metal, Radiator, Oil Cooler, Receiver, Pipework, Electrical Circuit Etc.
	Airend	24 Months/4,000 hours	60 Months/10,000 hours. Extended Limited Warranty available on major components. Refer to Operator's Manual.
	Engine	See Below	

2.5kVA - 8kVA GENERATORS	Package	12 Months/2,000 hours	Contact IR Network for Warranty (Parts only no labour).
	Alternator	12 Months/4,000 hours	Contact IR Network for Warranty (Parts only no labour).
	Engine	See Below	

9kVA - 550kVA GENERATORS	Package	12 Months/2,000 hours	Covers controls, Switches, Sheet Metal, Electrical Circuit etc.
	Alternator	24 Months/4,000 hours	Contact IR Network for Warranty.
	Engine	See Below	

Light Tower	Package	12 Months/2,000 hours	Covers Controls, Switches, Sheet Metal, Electrical Circuit etc.
	Alternator	12 Months/4,000 hours	Extended Warranty of 24 Months/4,000 hrs. for Lightsource introduced 8/16/99.
	Engine	See Below	

ENGINES			
	Months	Hours	Comments
Caterpillar	12	Unlimited	Extended Warranty provided via engine supplier's own approved network at time of purchase.
Cummins	24	2,000	Extended Warranty provided via engine supplier's own approved network at time of purchase.
Perkins	12	Unlimited	If under 500 hours in first year then below Applies.
	24	1,000	All components covered excluding Injectors.
John Deere (IN COMPRESSORS)	24	2,000	5 years/5000 hours using OEM fluids and filters with \$250 deductible
(IN GENERATORS)	24	2,000	24 months/4,000 hrs. Available from IR with use of Genuine IR parts and oils at prescribed service intervals. Contact IR Network.
Deutz	0 - 12	Unlimited	All components covered.
	13 - 24	Unlimited	Major components covered. Further Extended Warranty on major components provided via Engine Supplier's own approved network at time of Purchase.
Ingersoll Rand	24	4,000	Extended warranty of 60 months/10,000 hrs. When using Genuine Ingersoll Rand fluids and parts on major Components.
Kubota (North America only)	24	2,000	Extended warranty of 36 months/3,000 hrs. on major components, parts only, available from Kubota.
(Western Europe & Oceania)	24	2,000	No extended warranty available.
(Central & South America, Asia, Middle East & Africa)	12	1,000	No extended warranty available.

Mitsubishi	24	2,000	2 years/4,000 hours using IR fluids and filters
Volvo	24	2,000	2 years/4,000 hours using IR fluids and filters

PARTS

Ingersoll Rand	Months	Hours	Comments
	6	Unlimited	Parts only available from IR Network.

AIREND EXCHANGE

Airend	Months	Hours	Comments
	12	2,000	24 months/4,000 hours. Available from IR Network

CONSTRUCTION TOOLS

Construction Tools	Months	Hours	Comments
	12	N/A	Optional 36 months extended warranty available from IR. All warranty covers parts only replacement.

NOTE: Actual warranty times may change. Consult the manufacturer’s warranty policy as shipped with each new product.

Extended Limited Airend Warranty

Ingersoll Rand Portable Compressor Division is pleased to announce the availability of extended limited airend warranty. Announcement of the extended warranty coincides with the introduction of Pro-Tec™ Compressor Fluid. Pro-Tec™ Compressor Fluid is an amber coloured fluid specially formulated for Portable Compressors and is being provided as the factory filled fluid for all machines except ¹ XHP650/900/1070

All machines have the standard airend warranty, - *The earlier of 24 months from shipment to, or the accumulation of 4000 hours of service by the initial user.*

The warranty against defects will include replacement of the complete Airend, provided the original Airend is returned assembled and unopened.

The optional limited warranty is the earlier of 60 months from shipment to, or the accumulation of 10,000 hours of service. The optional warranty is limited to defects in major components (rotors, housings, gears and bearings), and is automatically available when the following conditions are met:

1. The original airend is returned assembled and unopened.
2. Submissions of proof that Ingersoll Rand fluid, filters and separators have been used. Refer to the Operation and Parts manual for the correct fluids, filters and separator elements required.
3. Submissions of proof that maintenance intervals have been followed.

Warranty	Time	*Bare Airend	**Airend Components
Standard	2yrs/4,000 hrs	100% Parts & Labour	100% Parts & Labour
Optional	5yrs/10,000 hrs	100% Parts & Labour	0%

*BARE AIREND - pertains to major airend parts (rotors, housings, gears and bearings).

**AIREND COMPONENTS - pertains to auxiliary attachments to the bare airend (seals, pumps, valves, tubes, hoses, fittings and filter housing).

Pro-Tec™ and XHP505 Compressor Fluids are available from your local Ingersoll Rand branch or distributor.

For units operating within the USA & Canada, call the Mocksville Product Support Department on 1-800-633-5206

¹ XHP650/900/1070/1170 will continue to use XHP505 and will have the extended warranty when above conditions are met.

Warranty Registration

FOR UNITS SOURCED FROM HORWICH, UK

Complete Machine Registration

To initiate the machine warranty, fill out the “Warranty Registration” form 85040285 supplied as part of the machine documentation, keep a copy for your records and mail the original to:

Ingersoll Rand European Sales Ltd.
Portable Power Business
Paragon Business Park
Chorley New Road
Horwich
Bolton
BL6 6LN
United Kingdom

Attn.: Customer Service Department

NOTE: Completion of this form validates the warranty.

Engine Registration

IR powered machines do not require separate engine registration.

Deutz require a separate engine registration form to be completed and mailed direct to their Cologne office. The form is supplied as part of the machine documentation for Deutz powered machines.

Caterpillar, Cummins and Perkins do not require a separate registration form but they stipulate that any new engine should be registered with their local dealer to initiate warranty.

You **MUST** provide proof of the “in-service” date when requesting engine warranty repairs.

FOR UNITS SOURCED FROM MOCKSVILLE, USA**Complete Machine Registration**

Machines shipped to locations within the United States do not require a warranty registration unless the machine status changes (i.e. change of ownership).

Machines shipped outside the United States require notification be made to initiate the machine warranty.

Fill out the Warranty Registration Form in this section, keep a copy for your records and mail form to:

Ingersoll Rand Company
P.O. Box 868,
Mocksville, North Carolina 27028
Attn.: Warranty Department

NOTE: Completion of this form validates the warranty.

Engine Registration

IR powered machines do not require separate engine registration.

John Deere requires a separate engine registration be completed and mailed direct to John Deere.

Separate engine registration material is included with this literature package for John Deere powered machines.

All other engine manufacturers do not require a separate engine registration.

You **MUST** present proof of in-service date at time of requesting engine warranty service.

Portable Power

Extended Warranty Registration Form

Customer Details

Company Name : _____

Contact Name : _____

Signature : _____

Company Address : _____

Post/Zip Code : _____

Country : _____

Phone Number : _____

Fax Number : _____

e-mail : _____

Service Provider Details

Service Provider/Distributor : _____

Branch Office : _____

Machine Details

Product Type : _____

Model : _____

Serial Number : _____

Engine Serial Number : _____

Engine Model Number : _____

Airend Serial Number : _____

Alternator Serial Number : _____

Date of start up : _____

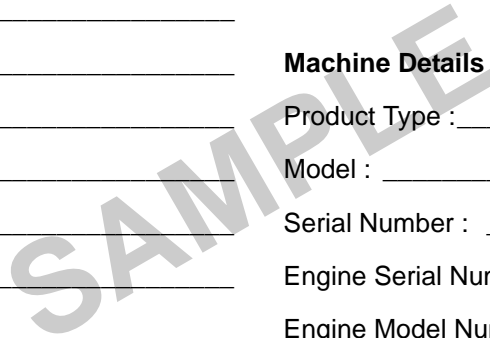









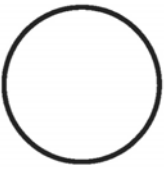















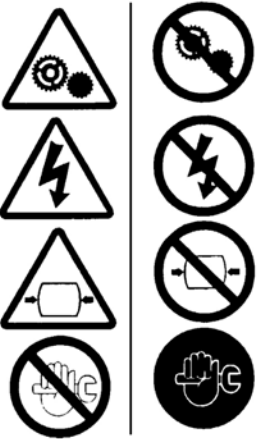

















Decals

Decals

GRAPHIC FORM AND MEANING OF ISO SYMBOLS

 Prohibition / Mandatory	 Information / Instructions	 Warning
 WARNING: Electrical shock risk.	 WARNING - Pressurised component or system.	 WARNING - Hot surface.
 WARNING - Pressure control.	 WARNING - Corrosion risk.	 WARNING - Air/gas flow or Air discharge.
 WARNING - Pressurised vessel.	 WARNING - Hot and harmful exhaust gas.	 WARNING - Maintain correct tyre pressure. (Refer to the GENERAL INFORMATION section of this manual).
 WARNING - Flammable liquid.	 WARNING - Before connecting the tow bar or commencing to tow consult the operation and maintenance manual.	 WARNING - For operating temperature below 0°C, consult the operation and maintenance manual.

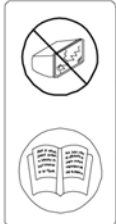
 <p>WARNING Do not undertake any maintenance on this machine until the electrical supply is disconnected and the air pressure is totally relieved.</p>	 <p>WARNING Consult the operation and maintenance manual before commencing any maintenance.</p>	 <p>Do not breathe the compressed air from this machine.</p>
 <p>Do not remove the Operating and Maintenance manual and manual holder from this machine.</p>	 <p>Do not stack.</p>	 <p>Do not operate the machine without the guard being fitted.</p>
 <p>Do not stand on any service valve or other parts of the pressure system.</p>	 <p>Do not operate with the doors or enclosure open.</p>	 <p>Do not use fork lift truck from this side.</p>
 <p>Do not exceed the trailer speed limit.</p>	 <p>No naked lights.</p>	 <p>Do not open the service valve before the airhose is attached.</p>
 <p>Use fork lift truck from this side only.</p>	 <p>Emergency stop.</p>	 <p>Tie down point</p>

 <p>Lifting point.</p>	 <p>On (power).</p>	 <p>Off (power).</p>
 <p>Read the Operation and Maintenance manual before operation or maintenance of this machine is undertaken.</p>	 <p>When parking use prop stand, handbrake and wheel chocks.</p>	 <p>Compressor oil filling</p>
 <p>Diesel fuel No open flame.</p>	 <p>Parking brake.</p>	 <p>Rough Service Designation. Wet Location Operation.</p>
 <p>Replace any cracked protective shield.</p>	 <p>Oil drain.</p>	

Look for these signs on machines shipped to markets in North America, which point out potential hazards to the safety of you and others. Read and understand thoroughly. Heed warnings and follow instructions. If you do not understand, inform your supervisor.



(Red Background)

Indicates the presence of a hazard which **WILL** cause serious injury, death or property damage, if ignored.



(Orange Background)

Indicates the presence of a hazard which **CAN** cause serious injury, death or property damage, if ignored.



(Yellow Background)

Indicates the presence of a hazard which **WILL** or can cause injury or property damage, if



(Blue Background)

Indicates important set-up, operating or maintenance information.





! WARNING

**Improper operation of this equipment.
Can cause serious injury or death.**
Read Operator's Manual supplied with this machine before operation or servicing.

**Modification or alternation of this machine.
Can cause serious injury or death.**
Do not alter modify this machine without the express written consent of the manufacturer.



! WARNING

**Trapped air pressure.
Can cause serious injury or death**

Close service valve and operate tool to vent trapped air before performing any service







! WARNING

**Disconnected air hoses whip.
Can cause serious injury or death.**

When using air tools attach safety device (OSHA valve) at source of air supply for each tool.



! WARNING

**Falling of machine.
Can cause serious injury or death.**

Access lifting bail from inside machine.





! WARNING

**High pressure air.
Can cause serious injury or death.**

Relieve pressure before removing filler plugs/caps, fittings or covers.







! WARNING

**Door under pressure.
Can cause serious injury.**

Use both hands to open door when machine is running.



	
 WARNING	
<p>Collapsing jackstand. Can cause serious injury.</p> <p>Insert locking pin completely.</p>	
<p>Excessive towing speed. Can cause serious injury or death.</p> <p>Do NOT exceed 65 mph (105 km/hr.)</p> <p><i>For Highway Towable Units.</i></p>	

 WARNING	
<p>Excessive Towing Speed. CAN cause serious injury or death.</p> <p>Do NOT Tow on Highway. Do NOT exceed 20 mph (32 km/h)</p> <p><i>For Non-Highway Towable Machines</i></p>	

FREE SAFETY DECALS!

To promote communication of Safety Warnings on products manufactured by the Portable Compressor Division in Mocksville. N.C., Safety Decals are available **free** of charge. Safety decals are identified by the decal heading: **DANGER, WARNING or CAUTION.**

Decal part numbers are on the bottom of each decal and are also listed in the compressor's parts manual. Submit order for Safety Decals to the Mocksville Parts Service Department. The no charge order should contain only Safety Decals. Help promote product safety! Assure that decals are present on the machines. Replace decals that are not readable.

*****Always use Ingersoll Rand Replacement parts!*****



Noise Emission

Noise Emission

This section pertains only to machines distributed within the United States.



TAMPERING WITH NOISE CONTROL SYSTEM PROHIBITED

Federal law prohibits the following acts or the causing thereof:

(1) The removal or rendering inoperative by any persons, other than for purposes of maintenance, repair, or replacement, of any device or element of design incorporated into any new compressor for the purpose of noise control prior to its sale or delivery to the ultimate purchaser or while it is in use; or (2) the use of the compressor after such device or element of design has been removed or rendered inoperative by any person.

Among those acts included in the prohibition against tampering are these:

1. Removal or rendering inoperative any of the following:
 - a. the engine exhaust system or parts thereof
 - b. the air intake system or parts thereof
 - c. enclosure or parts thereof
2. Removal of any of the following:
 - a. fan shroud
 - b. vibration mounts
 - c. sound absorption material
3. Operation of the compressor with any of the enclosure doors open.

Compressor Noise Emission Control Information

- A. The removal or rendering inoperative, other than for the purpose of maintenance, repair, or replacement of any noise control device or element of design incorporated into this compressor in compliance with the noise control act;
- B. The use of this compressor after such device or element of design has been removed or rendered inoperative.

NOTE: The above information applies only to units that are built in compliance with the U.S. Environmental Protection Agency.

Ingersoll Rand Company reserves the right to make changes or add improvements without notice and without incurring any obligation to make such changes or add such improvements to products sold previously.

The Purchaser is urged to include the above provisions in any agreement for any resale of this compressor.

Noise Emission Control Maintenance Log

COMPRESSOR MODEL _____
SERIAL NO. _____
USER UNIT NO. _____

UNIT IDENTIFICATION	DEALER OR DISTRIBUTOR FROM WHOM PURCHASED:
Engine Make & Model: _____	_____
Serial No.: _____	_____
Purchaser or Owner: _____	_____
Address: _____	Date Purchased: _____

The Noise Control Act of 1972 (86 Stat. 1234) prohibits tampering with the noise control system of any compressor manufactured and sold under the above regulations, specifically the following acts or the causing thereof:

(1) the removal or rendering inoperative by any persons, other than for purposes of maintenance, repair, or replacement, of any device or element of design incorporated into new compressor for the purpose of noise control prior to its sale or delivery to the ultimate purchaser or while it is in use; or (2) the use of the compressor after such device or element of design has been removed or rendered inoperative by any person.

Noise Emission Warranty

The manufacturer warrants to the ultimate purchaser and each subsequent purchaser that this air compressor was designed, built and equipped to conform at the time of sale to the first retail purchaser, with all applicable U.S. EPA Noise Control Regulations.

This warranty is not limited to any particular part, component, or system of the air compressor. Defects in the design, assembly or in any part, component, or system of the compressor which, at the time of sale to the first retail purchaser, caused noise emissions to exceed Federal Standards are covered by this warranty for the life of the air compressor. (40FR204.58-1).

Introduction

The unit for which this Maintenance Log is provided conforms to U.S. EPA Regulations for Noise Emissions, applicable to Portable Air Compressors.

The purpose of this book is to provide (1) the Maintenance Performance Schedule for all required noise emission controls and (2) space so that the purchaser or owner can record what maintenance was done, by whom, where and when. Detailed instructions on the maintenance items below are given on the following page.

Maintenance Schedule

Item	Area	Period
A.	Compressed Air Leaks	As Detected
B.	Safety and Control Systems	As Detected
C.	Acoustic Materials	Daily
D.	Fasteners	100 hours
E.	Enclosure Panels	100 hours
F.	Air Intake & Engine Exhaust	100 hours
G.	Cooling Systems	250 hours
H.	Isolation Mounts	250 hours
I.	Engine Operation	See Operator's Manual
J.	Fuels & Lubricants	See Operator's Manual

A. Compressed Air Leaks

Correct all compressed air leaks during the first shutdown period after discovery. If severe enough to cause serious noise problems and efficiency loss, shut down immediately and correct the leak(s).

B. Safety and Control Systems

Repair or replace all safety and control systems or circuits as malfunction occurs. No compressor should be operated with either system bypassed, disabled, or nonfunctional.

C. Acoustic Materials

In daily inspections, observe these materials. Maintain all acoustic material as nearly as possible in its original condition. Repair or replace all sections that have: 1) sustained damage, 2) have partially separated from panels to which they were attached, 3) are missing, or have otherwise deteriorated due to severe operating or storage conditions.

D. Fasteners

All fasteners such as hinges, nuts, bolts, clamps, screws, rivets, and latches should be inspected for looseness after each 100 hours of operation. They should be retightened, repaired, or if missing, replaced immediately to prevent subsequent damage and noise emission increase.

E. Enclosure Panels

Enclosure panels should also be inspected at 100 hour operational intervals. All panels that are warped, punctured, torn, or otherwise deformed, such that their noise containment function is reduced, should be repaired or replaced before the next operation interval. Doors, access panels, and hatch closures especially, should be checked and adjusted at this time to insure continuous seating between gasket or acoustic material and the mating frame.

F. Air Intake and Engine Exhaust

Engine and compressor air intake and engine exhaust systems should be inspected after each 100 hours of operation for loose, damaged, or deteriorated components. Repairs or replacements should be made before the next period of use.

G. Cooling Systems

All components of the cooling system for engine water and compressor oil should be inspected every 250 hours of use. Any discrepancies found should be corrected before placing the unit back in operation. Unrestricted airflow over the radiator and oil cooler must be maintained at all times during operation.

H. Isolation Mounts

Engine/airend isolation mounts should be inspected after each 250 hours of operation. Those mounts with cracks or splits in the molded rubber, or with bent or broken bolts due to operation or storage in severe environments, all should be replaced with equivalent parts.

I. Engine Operation

Inspect and maintain engine condition and operation as recommended in the manuals supplied by the engine manufacturer.

J. Fuels and Lubricants

Use only the types and grades of fuels and lubricants recommended in the Ingersoll Rand Company and Engine Manufacturer's Operator and Maintenance Manuals.



Safety

Safety



(Red Background)

Indicates the presence of a hazard which **WILL** cause serious injury, death or property damage, if ignored.



(Orange Background)

Indicates the presence of a hazard which **CAN** cause serious injury, death or property damage, if ignored.



(Yellow Background)

Indicates the presence of a hazard which **WILL** or can cause injury or property damage, if



(Blue Background)

Indicates important set-up, operating or maintenance information.

General Information

Never operate unit without first observing all safety warnings and carefully reading the operation and maintenance manual shipped from the factory with this machine.

Ensure that the operator reads and understands the decals and consults the manuals before maintenance or operation.

Ensure that the Operation and Maintenance manual, and the manual holder, are not removed permanently from the machine.

Ensure that maintenance personnel are adequately trained, competent and have read the Maintenance Manuals.

Make sure that all protective covers are in place and that the canopy/doors are closed during operation.

The specification of this machine is such that the machine is not suitable for use in flammable gas risk areas. If such an application is required then all local regulations, codes of practice and site rules must be observed. To ensure that the machine can operate in a safe and reliable manner, additional equipment such as gas detection, exhaust spark arrestors, and intake (shut-off) valves may be required, dependant on local regulations or the degree of risk involved.

A weekly visual check must be made on all fasteners/fixing screws securing mechanical parts. In particular, safety-related parts such as coupling hitch, drawbar components, road-wheels, and lifting bail should be checked for total security.

All components which are loose, damaged or unserviceable, must be rectified without delay.

Air discharged from this machine may contain carbon monoxide or other contaminants which will cause serious injury or death. Do not breathe this air.

This machine produces loud noise with the doors open or service valve vented. Extended exposure to loud noise can cause hearing loss. Always wear hearing protection when doors are open or service valve is vented.

Never inspect or service unit without first disconnecting battery cable(s) to prevent accidental starting.

Do not use petroleum products (solvents or fuels) under high pressure as this can penetrate the skin and result in serious illness. wear eye protection while cleaning unit with compressed air to prevent debris from injuring eye(s).

Rotating fan blade can cause serious injury. Do not operate without guard in place.

Use care to avoid contacting hot surfaces (engine exhaust manifold and piping, air receiver and air discharge piping, etc.).

Ether is an extremely volatile, highly inflammable gas. When it is specified as a starting aid, use sparingly. **DO NOT USE ETHER IF THE MACHINE HAS GLOW PLUG STARTING AID OR ENGINE DAMAGE WILL RESULT.**

Never operate unit with guards, covers or screens removed. Keep hands, hair, clothing, tools, blow gun tips, etc. well away from moving parts.

Compressed Air

Compressed air can be dangerous if incorrectly handled. Before doing any work on the unit, ensure that all pressure is vented from the system and that the machine cannot be started accidentally.

Ensure that the machine is operating at the rated pressure and that the rated pressure is known to all relevant personnel.

All air pressure equipment installed in or connected to the machine must have safe working pressure ratings of at least the machine rated pressure.

If more than one compressor is connected to one common downstream plant, effective check valves and isolation valves must be fitted and controlled by work procedures, so that one machine cannot accidentally be pressurised/over pressurised by another.

Compressed air must not be used for a direct feed to any form of breathing apparatus or mask.

High Pressure Air can cause serious injury or death. Relieve pressure before removing filler plugs/caps, fittings or covers.

Air pressure can remain trapped in air supply line which can result in serious injury or death. Always carefully vent air supply line at tool or vent valve before performing any service.

The discharged air contains a very small percentage of compressor lubricating oil and care should be taken to ensure that downstream equipment is compatible.

If the discharged air is to be ultimately released into a confined space, adequate ventilation must be provided.

When using compressed air always use appropriate personal protective equipment.

All pressure containing parts, especially flexible hoses and their couplings, must be regularly inspected, be free from defects and be replaced according to the Manual instructions.

Avoid bodily contact with compressed air.

The safety valve located in the separator tank must be checked periodically for correct operation.

Whenever the machine is stopped, air will flow back into the compressor system from devices or systems downstream of the machine unless the service valve is closed. Install a check valve at the machine service valve to prevent reverse flow in the event of an unexpected shutdown when the service valve is open.

Disconnected air hoses whip and can cause serious injury or death. Always attach a safety flow restrictor to each hose at the source of supply or branch line in accordance with OSHA Regulation 29CFR Section 1926.302(b).

Never allow the unit to sit stopped with pressure in the receiver-separator system.

Materials

The following substances may be produced during the operation of this machine:

- brake lining dust
- engine exhaust fumes

AVOID INHALATION

Ensure that adequate ventilation of the cooling system and exhaust gases is maintained at all times.

The following substances are used in the manufacture of this machine and may be hazardous to health if used incorrectly:

- compressor lubricant
- engine lubricant
- preservative grease
- rust preventative
- diesel fuel
- battery electrolyte

AVOID INGESTION, SKIN CONTACT AND INHALATION OF FUMES.

Should compressor lubricant come into contact with the eyes, then irrigate with water for at least 5 minutes.

Should compressor lubricant come into contact with the skin, then wash off immediately.

Consult a physician if large amounts of compressor lubricant are ingested.

Consult a physician if compressor lubricant is inhaled.

Never give fluids or induce vomiting if the patient is unconscious or having convulsions.

Safety data sheets for compressor and engine lubricants should be obtained from the lubricant supplier.

Never operate the engine of this machine inside a building without adequate ventilation. Avoid breathing exhaust fumes when working on or near the machine.

This machine may include such materials as oil, diesel fuel, antifreeze, brake fluid, oil/air filters and batteries which may require proper disposal when performing maintenance and service tasks. Contact local authorities for proper disposal of these materials.

Battery

A battery contains sulphuric acid and can give off gases which are corrosive and potentially explosive. Avoid contact with skin, eyes and clothing. In case of contact, flush area immediately with water.

DO NOT ATTEMPT TO SLAVE START A FROZEN BATTERY SINCE THIS MAY CAUSE IT TO EXPLODE.

Exercise extreme caution when using booster battery. To jump battery, connect ends of one booster cable to the positive (+) terminal of each battery. Connect one end of other cable to the negative (-) terminal of the booster battery and other end to a ground connection away from dead battery (to avoid a spark occurring near any explosive gases that may be present). After starting unit, always disconnect cables in reverse order.

Radiator

Hot engine coolant and steam can cause injury. Ensure that the radiator filler cap is removed with due care and attention.

Do not remove the pressure cap from a HOT radiator. Allow radiator to cool down before removing pressure cap.

Generator Sets

The generator set is designed for safety in use. However, the responsibility for safe operation rests with those who install, use and maintain it. The following safety precautions are offered as a guide, which, if conscientiously followed, will minimise the possibility of accidents throughout the useful life of this equipment.

Emergency Stop Controls

NOTE: In addition to the key operated emergency stop control on the main control panel, a second control is provided at the socket control panel in the event of electrical hazards associated with generator operation. Use this second control to immediately isolate all electrical power to all sockets, then use the key control to stop the engine.

Operation of the generator must be in accordance with recognised electrical codes and local health and safety codes.

The generator set should be operated by those who have been trained in its use and delegated to do so, and who have read and understand the operator's manual. Failure to follow the instructions, procedures and safety precautions in the manual may increase the possibility of accidents and injuries.

Do not start the generator set unless it is safe to do so. Do not attempt to operate the generator set with a known unsafe condition. Fit a danger notice to the generator set and render it inoperative by disconnecting the battery and disconnecting all ungrounded conductors so others who may not know of the unsafe condition will not attempt to operate it until the condition is corrected.

An earth point is provided beneath the socket outlets.

The generator set should only be used with the earth point connected directly to the general earth/ground mass. An earth spike kit is available as an optional extra for this purpose (refer to the parts catalogue).

 **WARNING**

DO NOT OPERATE THE MACHINE UNLESS IT HAS BEEN SUITABLY EARTHED.

Generator sets must be connected to the load only by trained and qualified electricians who have been delegated to do so, and when required by applicable regulations, their work should be inspected, and accepted by the inspection agency having authority, prior to attempting to operate the generator set.

Do not make contact with electrically energised parts of the generator set and/or interconnecting cables or conductors with any part of the body or with any non-insulated conductive object.

Make sure the generator set is effectively grounded in accordance with all applicable Regulations prior to attempting to make or break load connections and prior to attempting operation.

Do not attempt to make or break electrical connections to generator sets standing in water or on wet ground.

Prior to attempting to make or break electrical connections at the generator set, stop the engine, disconnect the battery and disconnect and lock out the ungrounded conductors at the load end.

Keep all parts of the body and any hand-held tools or other conductive objects, away from exposed live parts of the generator set engine electrical system. Maintain dry footing, stand on insulating surfaces and do not contact any other portion of the generator set when making adjustments or repairs to exposed live parts of the generator set engine electrical system.

Replace the generator set terminal compartment cover as soon as connections have been made or broken. Do not operate the generator set without the terminal cover secured firmly in place.

Close and lock all access doors when the generator set is left unattended.

Do not use extinguishers intended for Class A or Class B fires on electrical fires. Use only extinguishers suitable for class BC or class ABC fires.

Keep the towing vehicle or equipment carrier, generator set, connecting cables, tools and all personnel at least 3 metres from all power lines and buried power cables, other than those connected to the generator set.

Attempt repairs only in clean, dry, well lighted and ventilated areas.

Connect the generator set only to loads and/or electrical systems that are compatible with its electrical characteristics and that are within it's rated capacity.

Transport

When loading or transporting machines ensure that the specified lifting and tie down points are used.

When loading or transporting machines ensure that the towing vehicle, its size, weight, towing hitch and electrical supply are all suitable to provide safe and stable towing at speeds either, up to the legal maximum for the country in which it is being towed or, as specified for the machine model if lower than the legal maximum.

Ensure that the maximum trailer weight does not exceed the maximum gross weight of the machine (by limiting the equipment load), limited by the capacity of the running gear.

NOTE: Gross mass (on data plate) is for the basic machine and fuel only, excluding any fitted options, tools, equipment and foreign materials.

Steps for determining correct load limit -

1. Locate the statement "The weight of cargo should never exceed xxx kg or xxx lbs" on your vehicle's placard.
2. This figure equals the available amount of cargo and luggage load capacity.
3. Determine the combined weight of luggage and cargo being loaded on the vehicle. That weight may not safely exceed the available cargo and luggage load capacity.

Before towing the machine, ensure that:-

- the tires and towing hitch are in a serviceable condition.
- the canopy is secure.
- all ancillary equipment is stored in a safe and secure manner.
- the brakes and lights are functioning correctly and meet necessary road traffic requirements.
- break-away cables/safety chains are connected to the towing vehicle.

The machine must be towed in a level attitude in order to maintain correct handling, braking and lighting functions. This can be achieved by correct selection and adjustment of the vehicle towing hitch and, on variable height running gear, adjustment of the drawbar.

To ensure full braking efficiency, the front (towing eye) section must always be set level.

When adjusting variable height running gear:-

Ensure front (towing eye) section is set level

When raising towing eye, set rear joint first, then front joint.

When lowering towing eye, set front joint first, then rear joint.

After setting, fully tighten each joint by hand and then tighten further to the next pin. Refit the pin.

When parking always use the handbrake and, if necessary, suitable wheel chocks.

Make sure wheels, tyres and tow bar connectors are in safe operating condition and tow bar is properly connected before towing.

Safety Chains/Connections and their Adjustment

The legal requirements for the joint operation of the breakaway cable and safety chains are as yet unidentified by 71/320/EEC or UK regulations. Consequently we offer the following advice/instructions.

Where brakes only are fitted:

- a. Ensure that the breakaway cable is securely coupled to the handbrake lever and also to a substantial point on the towing vehicle.
- b. Ensure that the effective cable length is as short as possible, whilst still allowing enough slackness for the trailer to articulate without the handbrake being applied.

Where brakes and safety chains are fitted:

- a. Loop the chains onto the towing vehicle using the towing vehicle hitch as an anchorage point, or any other point of similar strength.
- b. Ensure that the effective chain length is as short as possible whilst still allowing normal articulation of the trailer and effective operation of the breakaway cable.

Where safety chains only are fitted:

- a. Loop the chains onto the towing vehicle using the towing vehicle hitch as an anchorage point, or any other point of similar strength.
- b. When adjusting the safety chains there should be sufficient free length in the chains to allow normal articulation, whilst also being short enough to prevent the towbar from touching the ground in the event of an accidental separation of the towing vehicle from the trailer.

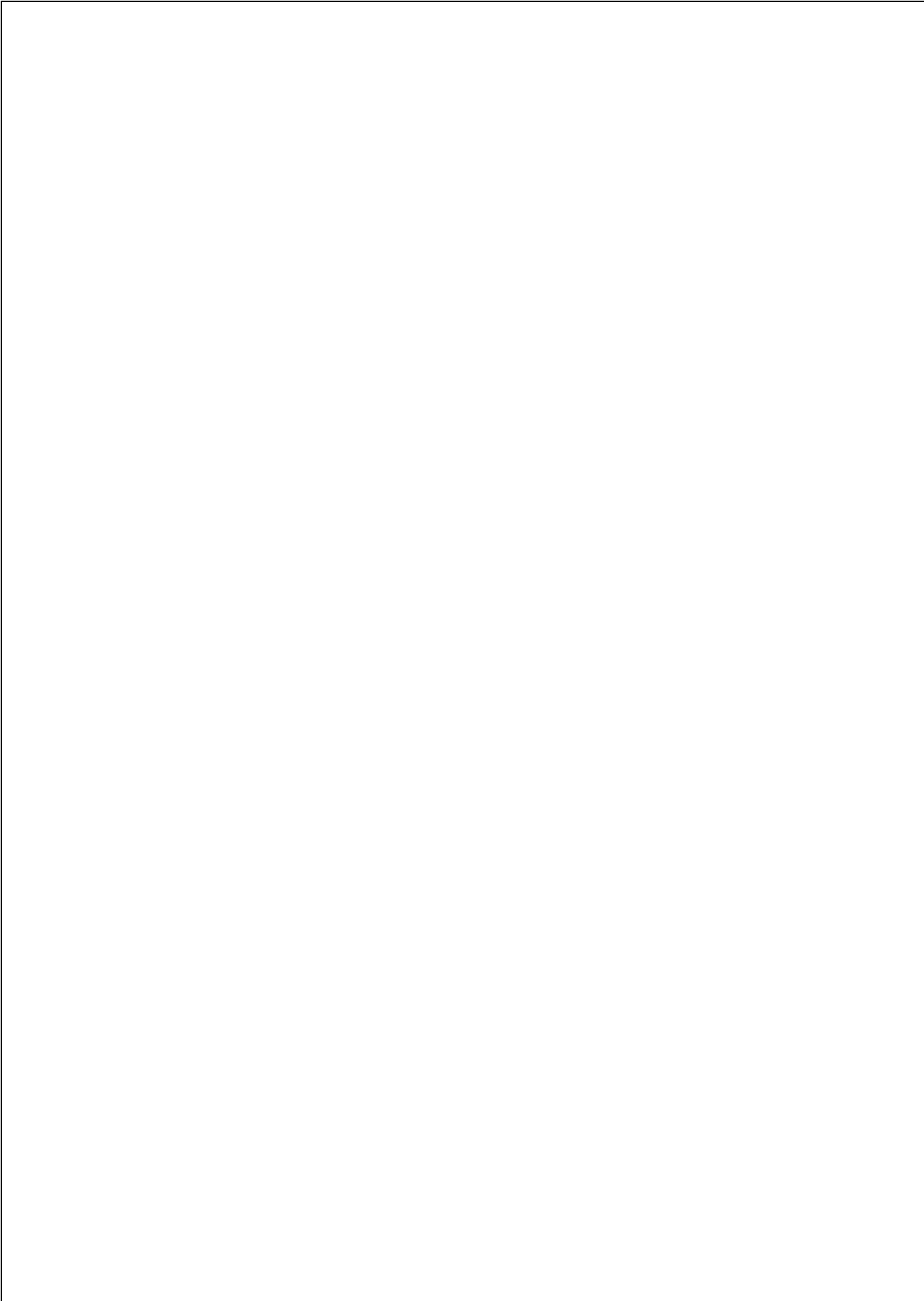



General Information

General Information

7/26E, 7/31E VARIABLE HEIGHT RUNNING GEAR
Unbraked version (Knott)

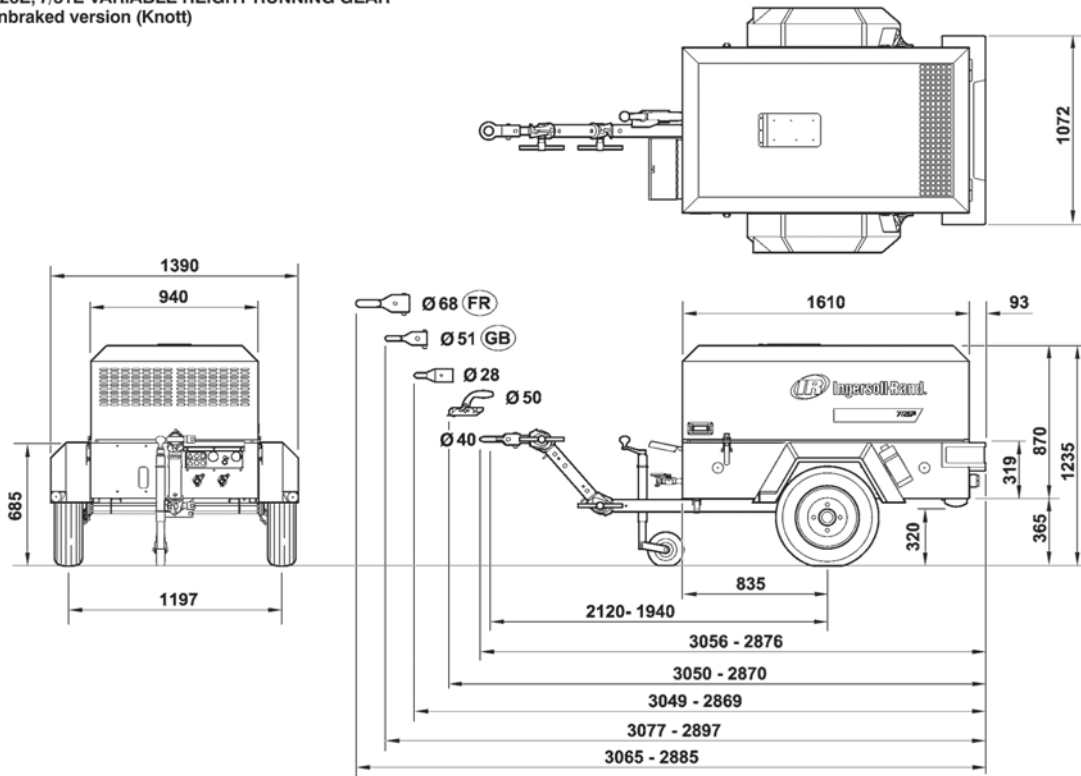

7/26E, 7/31E VARIABLE HEIGHT RUNNING GEAR
Braked version (Knott)

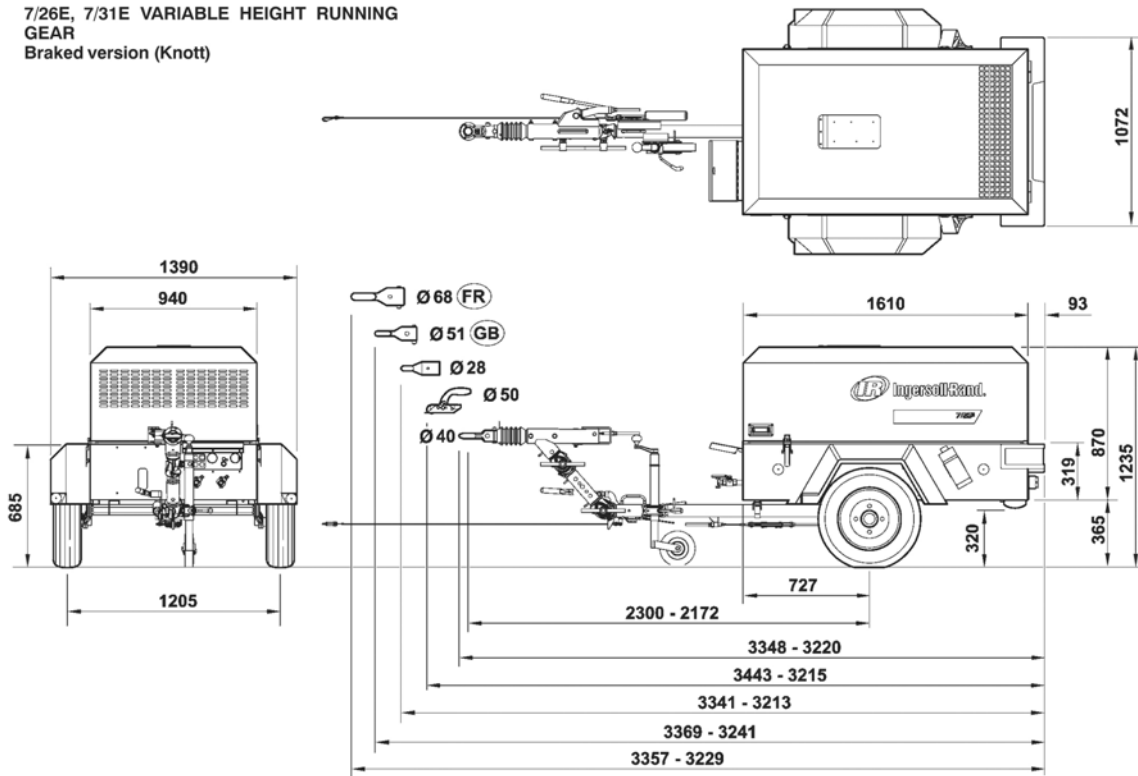

7/26E 7/31E FIXED HEIGHT RUNNING GEAR
Unbraked version (Knott)

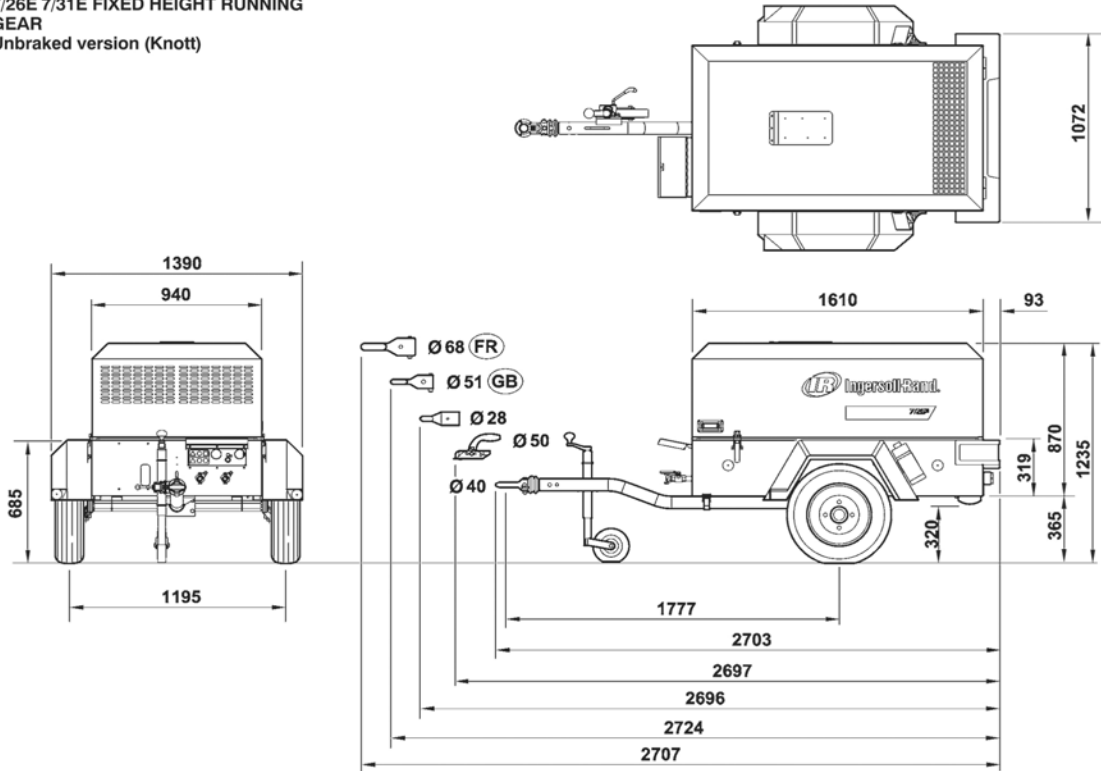

7/26E, 7/31E FIXED HEIGHT RUNNING GEAR
Braked version (Knott)

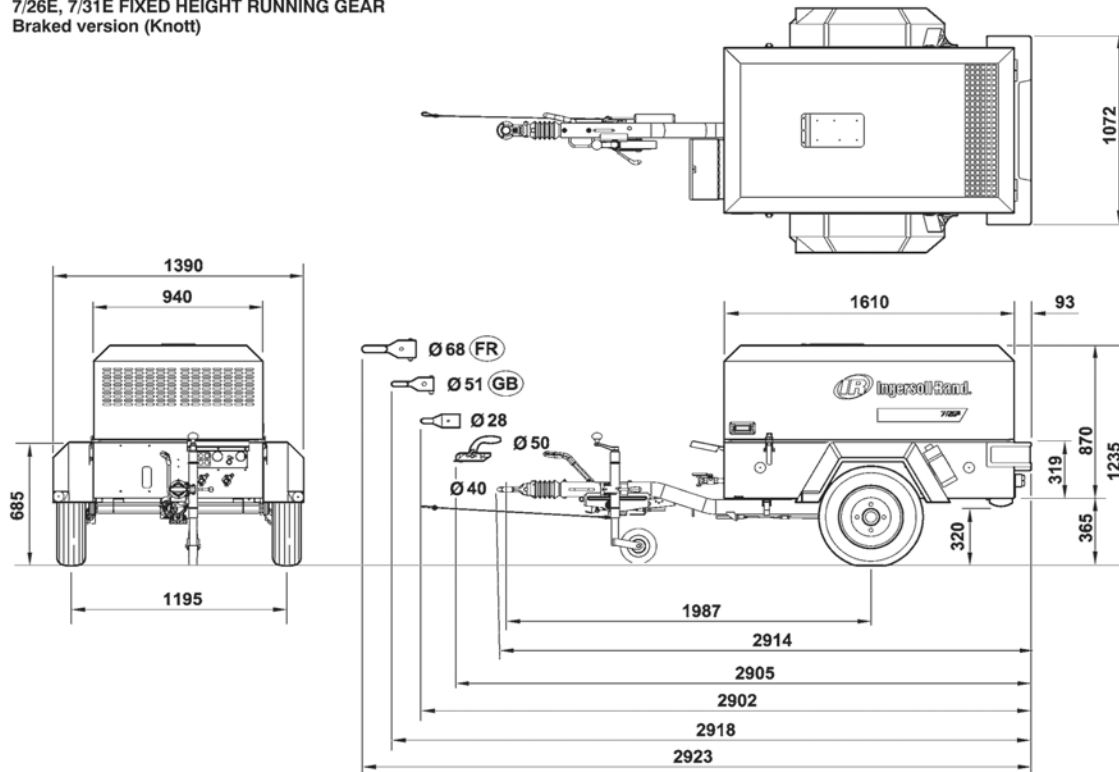

7/41 FIXED HEIGHT RUNNING GEAR
Braked version (Knott)

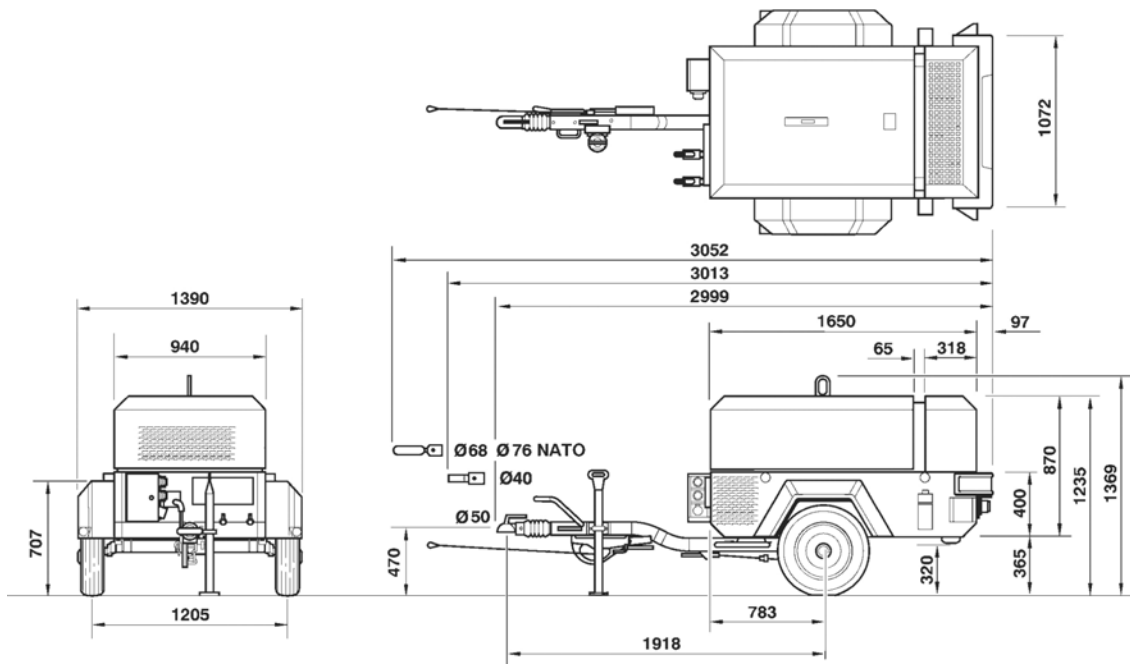

7/41 VARIABLE HEIGHT RUNNING GEAR
Braked version (Knott)

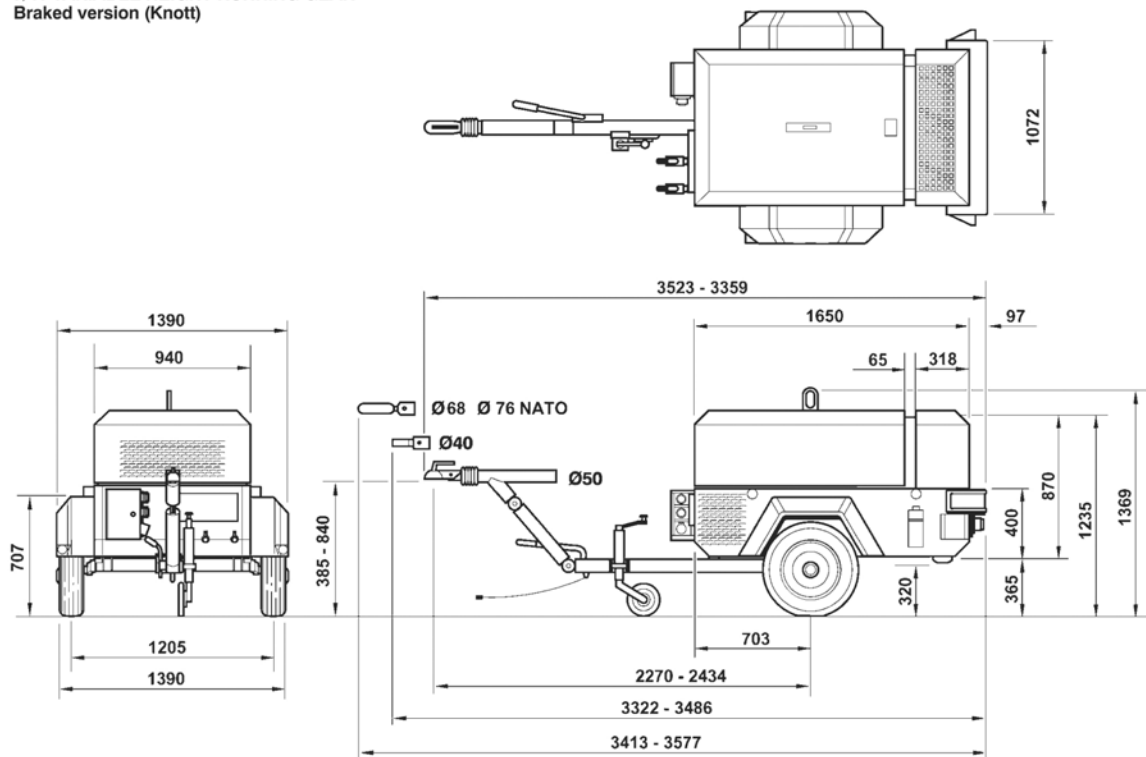

7/51 FIXED HEIGHT RUNNING GEAR
Braked version (Knott)

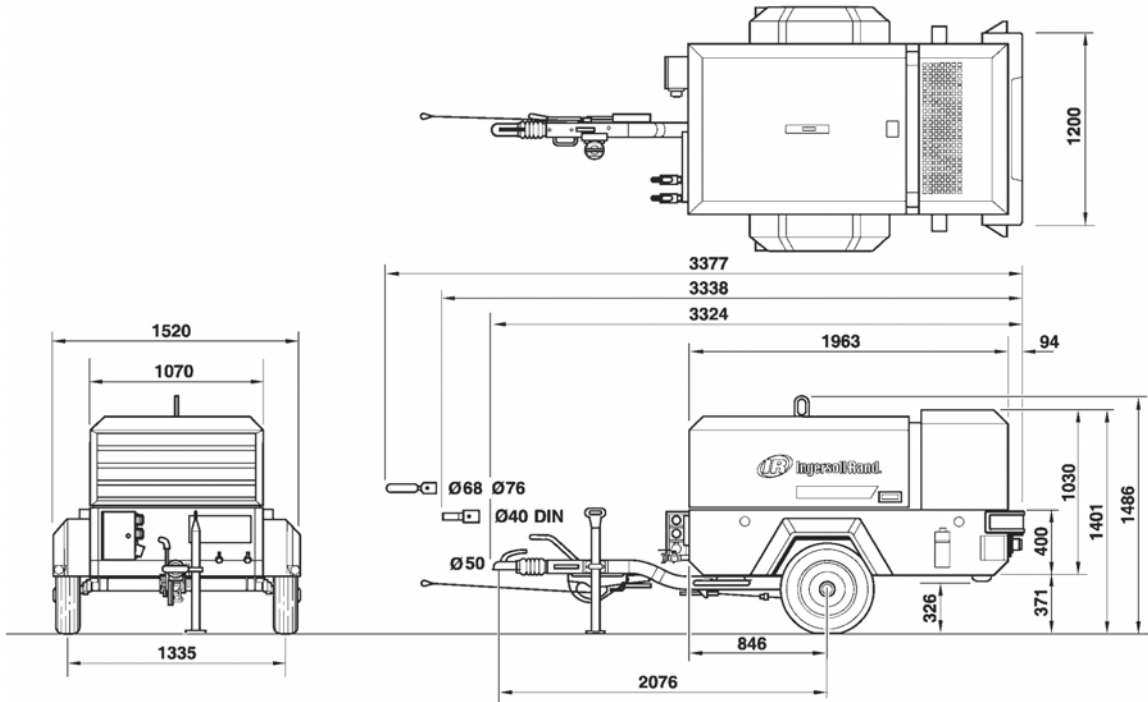

7/51 VARIABLE HEIGHT RUNNING GEAR
Braked version (Knott)

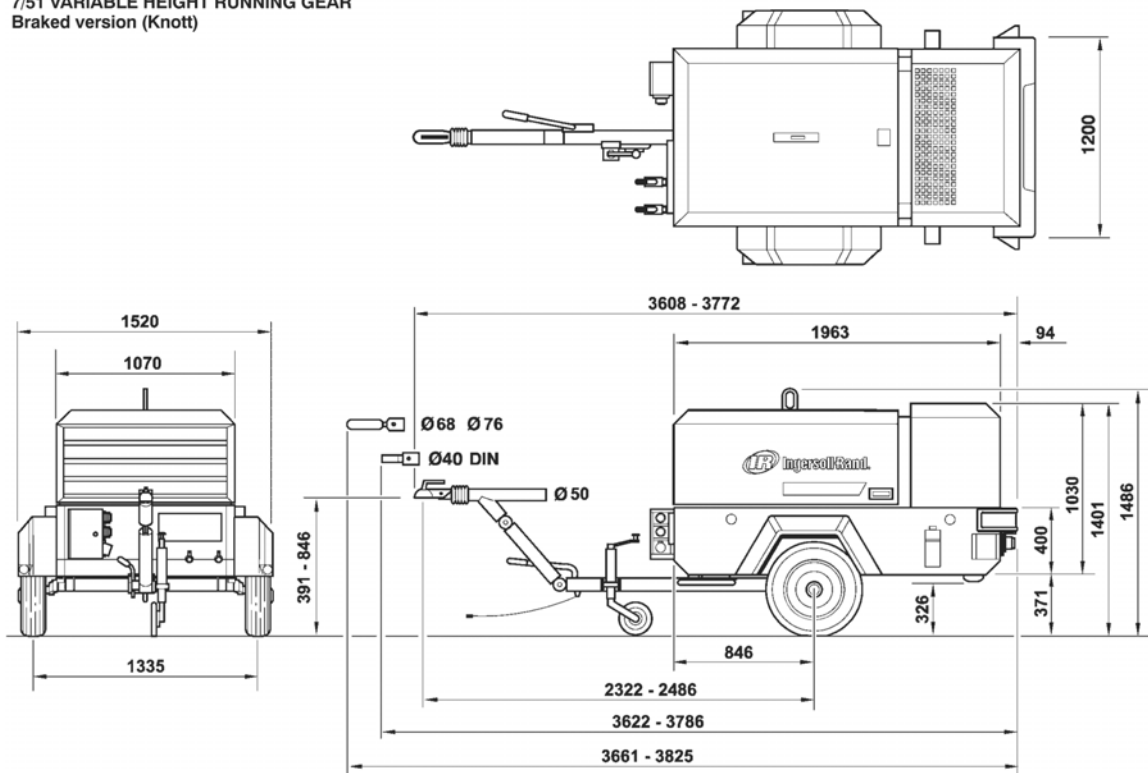

Compressor

Actual free air delivery (7/26E)	2.5 m ³ min ⁻¹ (90 CFM)
Actual free air delivery (7/31E)	3.0 m ³ min ⁻¹ (105 CFM)
Actual free air delivery (7/41)	4.0 m ³ min ⁻¹ (140 CFM)
Actual free air delivery (7/51)	5.0 m ³ min ⁻¹ (175 CFM)
Normal operating discharge pressure.	7 bar (100 PSI)
Maximum allowable pressure.	8.6 bar (125 PSI)
Safety valve setting.	10 bar (145 PSI)
Maximum pressure ratio (absolute).	7.5 : 1
Operating ambient temperature.	
Whisperised	-10° C to +46° C (14° F to 115° F)
Standard	-10° C to +52° C (14° F to 126° F)
Maximum discharge temperature.	120° C (248° F)
Cooling system.	Oil injection
Oil capacity (7/26E), (7/31E)	7.0 litres (1.8 US GAL)
Oil capacity (7/41)	8.0 litres (2.1 US GAL)
Oil capacity (7/51)	10.5 litres (2.8 US GAL)
Maximum oil system temperature.	120° C (248° F)
Maximum oil system pressure.	8.6 bar (125 PSI)

Lubricating Oil Specification

(for the specified ambient temperatures).

ABOVE -23° C(-9° F)

Recommended: Pro-Tec™

Approved: SAE 10W, API CF-4/CG-4

BELOW -23° C(-9° F)

Mandatory: IR Performance 500

Ingersoll Rand Pro-Tec™ compressor fluid is factory-fitted, for use at all ambient temperatures above -23° C(-9° F).

NOTE: Warranty may be extended only by continuous use of Pro-Tec™ and Ingersoll Rand oil filters and separators.

No other oil/fluids are compatible with Pro-Tec™.

No other oils/fluids should be mixed with Pro-Tec™ because the resulting mixture could cause damage to the airend.

In the event that Pro-Tec™ is not available and/or the end user needs to use an approved single grade engine oil, the complete system including separator/receiver, cooler and pipework must be flushed clear of the first fill fluid and new Ingersoll Rand oil filters installed. When this has been completed, the following oils are approved:

- a. for ambient temperatures above -23° C (-9° F), SAE 10W, API CF-4/CG-4.
- b. for ambient temperatures below -23° C (-9° F), IR Performance 500 only.

Safety data sheets can be obtained on request from the lubricant supplier.

For temperatures outside the specified ambient range, consult Ingersoll Rand.

Engine 7/26E

Type/model.	Ingersoll Rand 3IRH2N
Number of cylinders.	3
Oil capacity.	5.5 litres
Speed at full load.	2800 revs min ⁻¹
Speed at idle.	1700 revs min ⁻¹
Electrical system.	12V negative earth
Power available at 2800 revs min ⁻¹ .	21.2kW (28.5 HP)
Fuel tank capacity.	50 litres (11 US GAL)
Oil specification.	Refer engine section
Coolant capacity.	5 litres (1.3) US GAL

Engine 7/31E

Type/model.	Ingersoll Rand 3IRH8N
Number of cylinders.	3
Oil capacity.	6.7 litres (1.8 US GAL)
Speed at full load.	2800 revs min ⁻¹
Speed at idle.	1800 revs min ⁻¹
Electrical system.	12V negative earth
Power available at 2800 revs min ⁻¹ .	26kW (34.8 HP)
Fuel tank capacity.	50 litres (11.0 US GAL)
Oil specification.	Refer engine section
Coolant capacity.	5.0 litres (1.3 US GAL)

Engine 7/41

Type/model.	Ingersoll Rand 4IRH8N-2
Number of cylinders.	4
Oil capacity.	7.4 litres (1.9 US GAL)
Speed at full load.	2800 revs min ⁻¹
Speed at idle.	1500 revs min ⁻¹
Electrical system.	12V negative earth
Power available at 2800 revs min ⁻¹ .	35kW (47.0 HP)
Fuel tank capacity.	40 litres (10.6 US GAL)
Oil specification.	Refer engine section
Coolant capacity.	7.8 litres (2 US GAL)

Engine 7/51

Type/model.	Ingersoll Rand 4IRI8N
Number of cylinders.	4
Oil capacity.	9.5 litres (2.5 US GAL)
Speed at full load.	2400 revs min ⁻¹
Speed at idle.	1600 revs min ⁻¹
Electrical system.	12V negative earth
Power available at 2400 revs min ⁻¹ .	50kW (67.2 HP)
Fuel tank capacity.	50 litres (13.2 US GAL)
Oil specification.	Refer engine section
Coolant capacity.	9 litres (2.4 US GAL)

Sound Level Data ('W' Model)

A. To Pneuop code PN8NTC2.

Equivalent continuous sound pressure level.*

Rated load - 84 dB(A)

(Operator position :-1m from machine)

Sound power level (84/533/EEC) - 98 dB(A)

B. In compliance with 86/188/EEC.

Average sound pressure level at 10m

to 79/113/EEC.* - 70 dB(A)

(*Machine only :- at maximum load in open site conditions)

Fixed Height Running Gear - 7/26E, 7/31E

Unbraked version (Knott) 7/26E, 7/31E

Shipping weight.	620 kg (1370 lbs)
Maximum weight.	745 kg (1640 lbs)
Maximum horizontal towing force.	7.12 kN (1600 lbs)
Maximum vertical coupling load (nose weight).	74.5 kg (165 lbs)

Braked version (Knott) 7/26E, 7/31E

Shipping weight.	650 kg (1440 lbs)
Maximum weight.	745 kg (1640 lbs)
Maximum horizontal towing force.	7.12 kN (1600 lbs)
Maximum vertical coupling load (nose weight).	74.5 kg (165 lbs)

Variable Height Running Gear - 7/26E, 7/31E

Unbraked version (Knott) 7/26E, 7/31E

Shipping weight.	640 kg (1415 lbs)
Maximum weight.	745 kg (1640 lbs)
Maximum horizontal towing force.	7.12 kN (1600 lbs)
Maximum vertical coupling load (nose weight).	74.5 kg (165 lbs)

Braked version (Knott) 7/26E, 7/31E

Shipping weight.	670 kg (1480 lbs)
Maximum weight.	745 kg (1640 lbs)
Maximum horizontal towing force.	7.12 kN (1600 lbs)
Maximum vertical coupling load (nose weight).	74.5 kg (165 lbs)

Fixed Height Running Gear - 7/41, 7/51

Braked version (Knott) 7/41

Shipping weight.	650 kg (1430 lbs)
Maximum weight.	800 kg (1760 lbs)
Maximum horizontal towing force.	1233 kgf (2720 lbs)
Maximum vertical coupling load (nose weight).	90 kgf (198 lbs)

Braked version (Knott) 7/51

Shipping weight.	695kg (1790 lbs)
Maximum weight.	1100kg (2430 lbs)
Maximum horizontal towing force.	1233 kgf (2720 lbs)
Maximum vertical coupling load (nose weight).	100 kgf (220 lbs)

Variable Height Running Gear - 7/41, 7/51

Braked version (Knott) 7/41

Shipping weight.	695kg (1530 lbs)
Maximum weight.	800kg (1760 lbs)
Maximum horizontal towing force.	1233 kgf (2720 lbs)
Maximum vertical coupling load (nose weight).	90 kgf (198 lbs)

Braked version (Knott) 7/51

Shipping weight.	862kg (1990 lbs)
Maximum weight.	1100kg (2430 lbs)
Maximum horizontal towing force.	1233 kgf (2720 lbs)
Maximum vertical coupling load (nose weight).	100 kgf (220 lbs)

Wheels and Tyres (Knott)

Number of wheels 7/26E, 7/31E, 7/41, 7/51	2 x 4½ J
Tyre size 7/26E, 7/31E, 7/41, 7/51	155 R13
Tyre pressure 7/26E, 7/31E	2.4 bar (35 PSI)
Tyre pressure 7/41	2.7 bar (39 PSI)
Tyre pressure 7/51	2.9 bar (42 PSI)

Further information may be obtained by request through Ingersoll Rand customer services department.



Operating Instructions

Operating Instructions

Commissioning

Upon receipt of the unit, and prior to putting it into service, it is important to adhere strictly to the instructions given below in “*Prior to Starting*”.

Ensure that the operator reads and *understands* the decals and consults the manuals before maintenance or operation.

Ensure that the position of the emergency stop device is known and recognised by its markings. Ensure that it is functioning correctly and that the method of operation is known.

Running gear drawbar - Machines are shipped to some areas with the drawbar removed. Fitting involves four nuts/bolts to secure the drawbar to the axle and two bolts to fit the drawbar to the front of the machine with the saddle and spacer block.

Support the front of the machine, fit the wheel chocks to stop the machine moving and attach the drawbar. Refer to the torque value table in the “*Maintenance*” section of this manual for the correct torque values.



This is a safety critical procedure. Double check the torque settings after assembly

Fit the propstand and coupling. Remove the supports and set the machine level.

Before towing the unit, ensure that the tyre pressures are correct (refer to the “*General Information*” section of this manual) and that the handbrake is functioning correctly (refer to the “*Maintenance*” section of this manual). Before towing the unit during the hours of darkness, ensure that the lights are functioning correctly (where fitted).

Ensure that all transport and packing materials are discarded.

Ensure that the correct fork lift truck slots or marked lifting/tie down points are used whenever the machine is lifted or transported.

When selecting the working position of the machine ensure that there is sufficient clearance for ventilation and exhaust requirements, observing any specified minimum dimensions (to walls, floors etc.).

Adequate clearance needs to be allowed around and above the machine to permit safe access for specified maintenance tasks.

Ensure that the machine is positioned securely and on a stable foundation. Any risk of movement should be removed by suitable means, especially to avoid strain on any rigid discharge piping.

Attach the battery cables to the battery(s) ensuring that they are tightened securely. Attach the negative cable before attaching the positive cable.

 **WARNING**

All air pressure equipment installed in or connected to the machine must have safe working pressure ratings of at least the machine rated pressure, and materials compatible with the compressor lubricant (refer to the “*General Information*” section).

 **WARNING**

If more than one compressor is connected to one common downstream plant, effective check valves and isolation valves must be fitted and controlled by work procedures, so that one machine cannot accidentally be pressurised/over pressurised by another.

 **WARNING**

If flexible discharge hoses are to carry more than 7 bar pressure then it is recommended that safety retaining wires are used on the hoses.

Prior to Starting

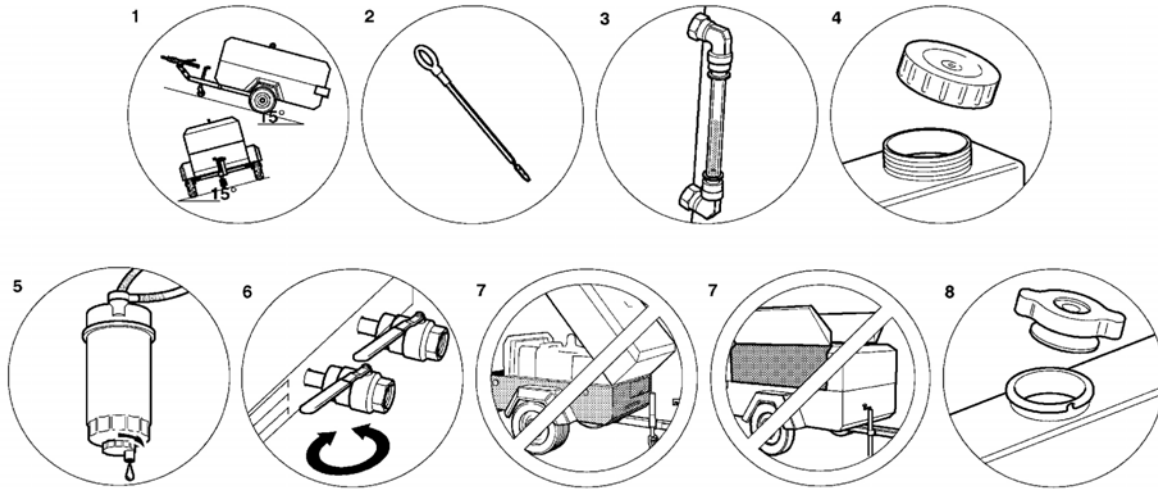

1. Place the unit in a position that is as level as possible. The design of the unit permits a 15 degree lengthways and sideways limit on out of level operation. It is the engine, not the compressor, that is the limiting factor.

When the unit has to be operated out of level, it is important to keep the engine oil level near the high level mark (with the unit level).

⚠ CAUTION

Do not overfill either the engine or the compressor with oil.

2. Check the engine lubrication oil in accordance with the operating instructions in the *Engine Operator's Manual*.
3. Check the compressor oil level in the sight glass located on the separator tank.
4. Check the diesel fuel level. A good rule is to top up at the end of each working day. This prevents condensation from occurring in the tank.

⚠ CAUTION

Use only a No. 2-D diesel fuel oil with a minimum octane number of 45 and a sulphur content not greater than 0.5%.

**CAUTION****When refueling:-**

- **switch off the engine.**
 - **do not smoke.**
 - **extinguish all naked lights.**
 - **do not allow the fuel to come into contact with hot surfaces.**
 - **wear personal protective equipment.**
5. Drain the fuel filter water separator of water, ensuring that any released fuel is safely contained.
 6. Open the service valve(s) to ensure that all pressure is relieved from the system. Close the service valve(s).
 - 7.

**CAUTION**

Do not operate the machine with the canopy/doors in the open position as this may cause overheating and operators to be exposed to high noise levels.

8. Check the radiator coolant level (with the unit level).

Check the air restriction indicator(s). Refer to the “*Maintenance*” section of this manual.

When starting or operating the machine in temperatures below or approaching 0° C, ensure that the operation of the regulation system, the unloader valve, the safety valve, and the engine are not impaired by ice or snow, and that all inlet and outlet pipes and ducts are clear of ice and snow.

Starting the Machine

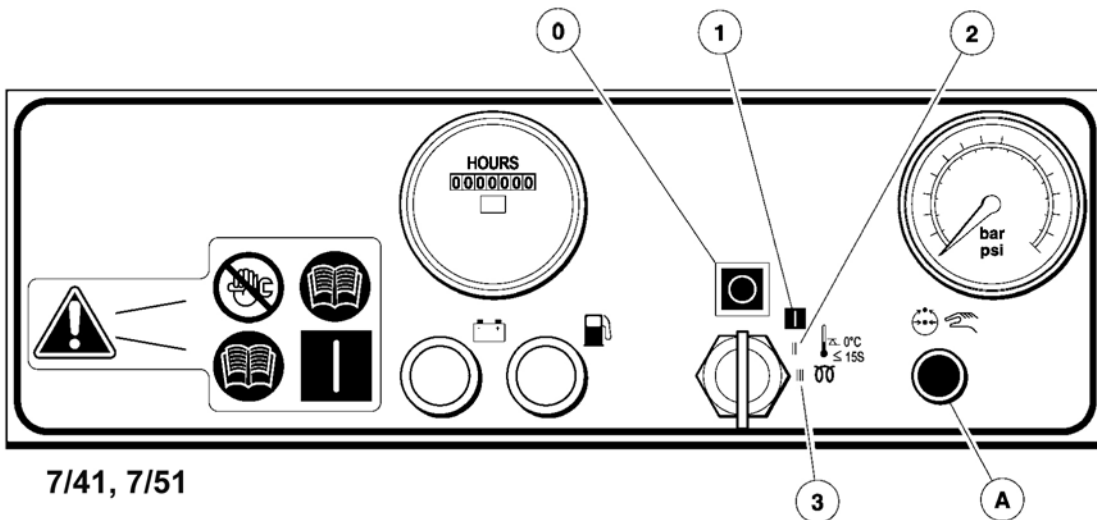
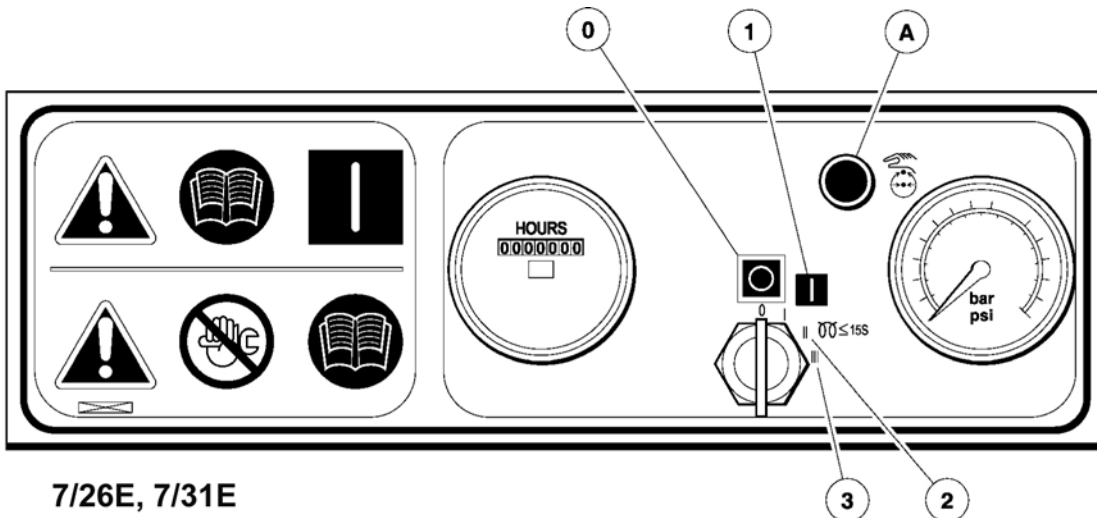

⚠ WARNING

Under no circumstances should volatile liquids such as Ether be used for starting this machine.

All normal starting functions are incorporated in the key operated switch.

- Turn the key switch to position **2** and hold for max 15 seconds to allow the air inlet heater to reach working temperature.
- Turn the key switch to position **3** (engine start position).
- Release to position **2** when the engine starts.
- Release to position **1** when the alternator charge light is extinguished.

At temperatures below 0° C or if there is difficulty starting first time:

- Open the service valve fully, with no hose connected.
- Complete starting sequence above.
- Close service valve as soon as engine runs freely.
- Do not allow machine to run for long periods with service valve open.
- Allow the engine to reach operating temperature.
- At this point in the operation of the machine it is safe to apply full load to the engine.

NOTE: Wear hearing protection at all times when the engine is started with the service valve open and air is flowing from the valve.

Push After Warm Up - When Fitted 7/26E, 7/31E, 7/41, 7/51 - Optional

NOTE: In order to allow the machine to start at a reduced load, a valve, which is operated by a button located on the instrument panel, is incorporated in the regulation system. (The valve automatically returns to the start position when the machine is switched off and air pressure relieved from the system).

- Allow the engine to reach its operating temperature - then press the button (A).
- At this point in the operation of the machine it is safe to apply full load to the engine.

Dual Pressure When Fitted

Machines which operate in excess of 7 bar can optionally be fitted with a dual pressure switch (B). This switch selects between 7 bar and the machine rated pressure, cfm remains nominally constant.

Starting and stopping are unaffected by the selection and during normal running the selector switch may be safely operated. Precaution must be taken to ensure that downstream equipment is rated to suit the available pressure.

The pressure gauge indicates which setting has been selected.

Stopping the Machine

- Close the service valve.
- Allow the machine to run unloaded for a short period of time to reduce the engine temperature.
- Turn the start switch to the **0** (OFF) position.

NOTE: As soon as the engine stops, the automatic blowdown valve will relieve all pressure from the system.

If the automatic blowdown valve fails to operate, then pressure must be relieved from the system by means of the service valve(s).



Never allow the machine to stand idle with pressure in the system.

Emergency Stopping

In the event that the unit has to be stopped in an emergency, **TURN THE KEY SWITCH LOCATED ON THE INSTRUMENT PANEL TO THE 0 (OFF) POSITION.**

Re-Starting After an Emergency

If the machine has been switched off because of a machine malfunction, then identify and correct the fault before attempting to re-start.

If the machine has been switched off for reasons of safety, then ensure that the machine can be operated safely before re-starting.

Refer to the *“Prior to Starting”* and *“Starting the Machine”* instructions earlier in this section before re-starting the machine.

Monitoring During Operation

Should any of the safety shut-down conditions occur, the unit will stop. These are:

- Low engine oil pressure
- High air discharge temperature
- High engine water temperature



To ensure an adequate flow of oil to the compressor at low temperature, never allow the discharge pressure to fall below 3.5 bar.

Decommissioning

When the machine is to be permanently decommissioned or dismantled, it is important to ensure that all hazard risks are either eliminated or notified to the recipient of the machine. In particular:-

- Do not destroy batteries or components containing asbestos without containing the materials safely.
- Do not dispose of any pressure vessel that is not clearly marked with its relevant data plate information or rendered unusable by drilling, cutting etc.
- Do not allow lubricants or coolants to be released into land surfaces or drains.
- Do not dispose of a complete machine without documentation relating to instructions for its use.

*****Always use Ingersoll Rand Replacement parts!*****



Maintenance

Maintenance

Maintenance Schedule

	Initial 500 miles /850 kms	Daily	Weekly	Monthly	3 Monthly/ 250 hrs	6 Monthly/ 500 hrs	12 Monthly/ 1000 hrs
Compressor Oil Level		C					
Engine Oil Level		C					
*Radiator Coolant Level		C					
Gauges/Lamps		C					
*Air Cleaner Service Indicators		C					
Fuel Tank (Fill at end of day)		C				D	
*Fuel/Water Separator Drain		C					
Oil Leaks		C					
Fuel Leaks		C					
Drain Water From Fuel Filters		D					
Coolant Leaks		C					
Radiator Filler Cap		C					
Air Cleaner Pre-cleaner Dumps			C				
Fan/Alternator Belts			C				
Generator Drive Belt			C				
Battery Connections/Electrolyte			C				
Tire Pressure and Surface			C				
*Wheel Lug Nuts				C			
Hoses (Oil, Air, Intake, etc.)				C			
Automatic Shutdown System				C			
Air Cleaner System				C			
Compressor Oil Cooler Exterior				C			
*Engine Rad./Oil Cooler Exterior				C			
Fasteners, Guards					C		
Air Cleaner Elements						R/WI	

*Disregard if not appropriate for this particular machine.

(1) or 3000 miles/5000km whichever is the sooner, (2) or as defined by local or national legislation

- C** Check (adjust, clean or replace as necessary)
- CBT** Check before towing.
- CR** Check and report
- D** Drain
- G** Grease
- R** Replace
- T** Test
- WI** When indicated if earlier.

Refer to specific sections of the operator’s manual for more information.

	Initial 500 miles/ 850 kms	Daily	Weekly	Monthly	3 Monthly/ 250 hrs	6 Monthly/ 500 hrs	12 Monthly/ 1000 hrs	18 Monthly/ 1500 hrs
*Fuel/Water Separator Element						R		
Compressor Oil Filter Element						R		
Compressor Oil						R		
Engine Oil Change						R		
Engine Oil Filter						R		
*Water Pump Grease.							R	
*Wheels (Bearings, Seals, etc.)				I		C		
*Engine Coolant						C	R	
Fuel Filter Element						R		
*Injection Nozzle Check								C
Shutdown Switch Settings							T	
Scavenger Orifice & Related Parts							C	
Oil Separator Element							R	
*Feed Pump Strainer Cleaning.							C	
Coolant Replacement							R	
*Valve Clearance Check							C	
Lights (running, brake, & turn)		CBT						
Pintle Eye Bolts		CBT						
*Brakes	C				C			
*Brake linkage	C							
Emergency stop		T						
Fasteners		C						
Running gear linkage				G				
Safety valve					C			
Running gear bolts(1)					C			

*Disregard if not appropriate for this particular machine.

(1) or 3000 miles/5000km whichever is the sooner, (2) or as defined by local or national legislation

C Check (adjust, clean or replace as necessary)

G Grease

CBT Check before towing.

R Replace

CR Check and report

T Test

D Drain

WI When indicated if earlier.

Refer to specific sections of the operator's manual for more information.

	Initial 500 miles	Daily	Weekly	Monthly	3 Monthly/ 250 hrs	6 Monthly/ 500 hrs	12 Monthly/ 1000 hrs
Scavenge line						C	
Pressure system						C	
Engine breather element							C
Pressure gauge							C
Pressure regulator							C
Separator tank (2) exterior							CR
Lubricator (Fill)		C					

	2 Yrs	4 Yrs	6 Yrs				
Safety valve	C						
Hoses		R					
Separator tank (2) interior			C				

*Disregard if not appropriate for this particular machine.

(1) or 3000 miles/5000km whichever is the sooner, (2) or as defined by local or national legislation

- C** Check (adjust, clean or replace as necessary)
- CBT** Check before towing.
- CR** Check and report
- D** Drain
- G** Grease
- R** Replace
- T** Test
- WI** When indicated if earlier.

Refer to specific sections of the operator's manual for more information.

Routine Maintenance

This section refers to the various components which require periodic maintenance and replacement.

The “*Maintenance Schedule*” indicates the various components’ descriptions and the intervals when maintenance has to take place. Oil capacities, etc., can be found in the “*General Information*” section of this manual.

For any specification or specific requirement on service or preventative maintenance for the engine, refer to the Engine Manufacturer’s Manual.

Compressed air can be dangerous if incorrectly handled. Before doing any work on the unit, ensure that all pressure is vented from the system and that the machine cannot be started accidentally.

If the automatic blowdown fails to operate, then pressure must be gradually relieved by operating the manual blowdown valve. Suitable personal protective equipment should be worn.

Ensure that maintenance personnel are adequately trained, competent and have read the Maintenance Manuals.

Prior to attempting any maintenance work, ensure that:-

- all air pressure is fully discharged and isolated from the system. If the automatic blowdown valve is used for this purpose, then allow enough time for it to complete the operation.
- the discharge pipe/manifold area is depressurised by opening the discharge valve, whilst keeping clear of any airflow from it.

MINIMUM PRESSURE VALVE - WHEN FITTED

NOTE: Pressure will always remain in the part of the system between the minimum pressure valve and the discharge valve after operation of the auto blowdown valve.

This pressure must be relieved by carefully:

- a. Disconnecting any downstream equipment.
 - b. Opening the discharge valve to atmosphere.
- (Use hearing protection if necessary).
- the machine cannot be started accidentally or otherwise, by posting warning signs and/or fitting appropriate anti-start devices.
 - all residual electrical power sources (mains and battery) are isolated.

Prior to opening or removing panels or covers to work inside a machine, ensure that:-

- anyone entering the machine is aware of the reduced level of protection and the additional hazards, including hot surfaces and intermittently moving parts.
- the machine cannot be started accidentally or otherwise, by posting warning signs and/or fitting appropriate anti-start devices.

Prior to attempting any maintenance work on a running machine, ensure that:-

- the work carried out is limited to only those tasks which require the machine to run.
- the work carried out with safety protection devices disabled or removed is limited to only those tasks which require the machine to be running with safety protection devices disabled or removed.
- all hazards present are known (e.g. pressurised components, electrically live components, removed panels, covers and guards, extreme temperatures, inflow and outflow of air, intermittently moving parts, safety valve discharge etc.).
- appropriate personal protective equipment is worn.
- loose clothing, jewelry, long hair etc. is made safe.
- warning signs indicating that Maintenance Work is in Progress are posted in a position that can be clearly seen.

Upon completion of maintenance tasks and prior to returning the machine into service, ensure that:-

- the machine is suitably tested.
- all guards and safety protection devices are refitted.
- all panels are replaced, canopy and doors closed.
- hazardous materials are effectively contained and disposed of.

Protective Shutdown System

Comprises:

- Low engine oil pressure switch.
- High discharge air temperature switch.
- High engine water temperature switch.
- Alternator/drive belt failure circuit.
- Low engine fuel level switch.

Low Engine Oil Pressure Switch.

At three month intervals, test the engine oil pressure switch circuit as follows:

- Start the machine.

NOTE: Do not press the load button.

- Remove a wire from one terminal of the switch. The machine should shutdown.

At twelve month intervals, test the engine oil pressure switch as follows:

- Remove the switch from the machine.
- Connect it to an independent low pressure supply (either air or oil).
- The switch should operate at 1.0 bar.
- Refit the switch.

Temperature Switch (ES).

At three month intervals, test the temperature switch circuit(s) as follows:

- Start the machine.

NOTE: Do not press the load button.

- Disconnect each switch in turn. The machine should shutdown.
- Re-connect the switch.

High Discharge Air Temperature Switch (ES).

At twelve month intervals, test the air discharge temperature switch(es) by removing it from the machine and immersing in a bath of heated oil. The switch should operate at 120° C. Refit the switch.

High Water Temperature Switch

At twelve month intervals, test the water temperature switch by removing it from the machine and immersing in a bath of heated oil. The switch should operate at 105° C. Refit the switch.

Alternator/Drive Belt Failure Circuit.

At twelve month intervals test the alternator drive belt failure circuit as follows:

- Remove the drive belt from the machine.
- Turn the key switch to position **1**, the alternator charge light will illuminate.
- Turn the key switch to position **3** (engine start position).
- The machine should shutdown when the key switch is returned to position **1**.

Low Engine Fuel Level Switch.

At three month intervals, test the low engine fuel level switch circuit as follows:

- Start the machine.

NOTE: Do not press the load button.

- Disconnect the switch, the machine should shutdown.
- Re-connect the switch.

At twelve month intervals, test the low engine fuel level switch by removing and operating the float manually.



Never remove or replace switches when the machine is running.

Scavenge Line

The scavenge line runs from the combined orifice/drop tube in the separator tank, to the orifice fitting located in the airend.

Examine the orifice, check valve and hoses at every service or in the event of oil carryover into the discharge air.

It is good preventative maintenance to check that the scavenge line and tube are clear of any obstruction each time the compressor lubricant is changed as any blockage will result in oil carryover into the discharge air.

Compressor Oil Filter

Refer to the “*Maintenance Schedule*” in this section for the recommended servicing intervals.

Removal

WARNING

Do not remove the filter(s) without first making sure that the machine is stopped and the system has been completely relieved of all air pressure. (Refer to “*Stopping the Machine*” in the “*Operating Instructions*” section of this manual).

Clean the exterior of the filter housing and remove the spin-on element by turning it in a counter-clockwise direction.

Inspection

Examine the filter element.

CAUTION

If there is any indication of the formation of varnishes, shellacs or lacquers on the filter element, it is a warning that the compressor lubricating and cooling oil has deteriorated and that it should be changed immediately. Refer to “*Lubrication*” later in this section.

Reassembly

Clean the filter gasket contact area and install the new element by screwing in a clockwise direction until the gasket makes contact with the filter housing. Tighten a further $\frac{1}{2}$ to $\frac{3}{4}$ of a revolution.

CAUTION

Start the machine (refer to “*Prior to Starting*” and “*Starting the Machine*” in the “*Operating Instructions*” section of this manual) and check for leakage before the machine is put back into service.

Compressor Oil Separator Element

Normally the separator element will not require periodic maintenance provided that the air and oil filter elements are correctly maintained.

If, however, the element has to be replaced, then proceed as follows:

Removal

WARNING

Do not remove the filter(s) without first making sure that the machine is stopped and the system has been completely relieved of all air pressure. (Refer to “Stopping the Machine” in the “Operating Instructions” section of this manual).

Disconnect all hoses and tubes from the separator tank cover plate. Remove the drop-tube from the separator tank cover plate and then remove the cover plate. Remove the separator element.

Inspection

Examine the filter element. Examine all hoses and tubes, and replace if necessary.

Reassembly

Thoroughly clean the orifice/drop tube and filter gasket contact area before reassembly. Install the new element.

For 7/26E and 7/31E models replace element O-ring in every reassembly.

WARNING

Do not remove the staple from the anti-static gasket on the separator element since it serves to ground any possible static build-up. Do not use gasket sealant since this will affect electrical conductance.

Reposition the cover plate, taking care not to damage the gasket, and replace the cover plate screws tightening in a criss-cross pattern to the recommended torque (refer to the “Torque Values” table later in this section).

Engage the adaptor in the cover plate with the drop-tube integral with the filter, reconnect all hoses and tubes to the separator tank cover plate.

Replace the compressor oil (refer to “Lubrication” later in this section).

 **CAUTION**

Start the machine (refer to “*Prior to Starting*” and “*Starting the Machine*” in the “*Operating Instructions*” section of this manual) and check for leakage before the machine is put back into service.

Compressor Oil Cooler and Engine Radiator

When grease, oil and dirt accumulate on the exterior surfaces of the oil cooler and radiator, the efficiency is impaired. It is recommended that each month the oil cooler and radiator be cleaned by directing a jet of compressed air, (carrying if possible a non-flammable cleaning solvent) over the exterior core of the cooler/radiator. This should remove any accumulation of oil, grease and dirt from the exterior core of the cooler so that the entire cooling area can radiate the heat of the lubricating and cooling oil/water into the air stream.

 **WARNING**

Hot engine coolant and steam can cause injury. When adding coolant or antifreeze solution to the engine radiator, stop the engine at least one minute prior to releasing the radiator filler cap. Using a cloth to protect the hand, slowly release the filler cap, absorbing any released fluid with the cloth. Do not remove the filler cap until all excess fluid is released and the engine cooling system fully depressurised.

 **WARNING**

Follow the instructions provided by the antifreeze supplier when adding or draining the antifreeze solution. It is advisable to wear personal protective equipment to prevent skin and eye contact with the antifreeze solution.

Air Filter Elements

The air filter should be inspected regularly (refer to the “*Maintenance Schedule*”) and the element replaced when the restriction indicator shows red or every 6 Months (500 hours), whichever comes first. The dust collector box(es) should be cleaned daily (more frequently in dusty operating conditions) and not allowed to become more than half full.

Removal



Never remove and replace element(s) when the machine is running.

Clean the exterior of the filter housing and remove the filter element by releasing the nut.

Inspection

Check for cracks, holes or any other damage to the element by holding it up to a light source, or by passing a lamp inside.

Check the seal at the end of the element and replace if any sign of damage is evident.

Reassembly

Assemble the new element into the filter housing ensuring that the seal seats properly.

Reset the restriction indicator by depressing the rubber diaphragm.

Assemble the dust collector box parts, ensuring that they are correctly positioned.

Before restarting the machine, check that all clamps are tight.

Ventilation

Always check that the air inlets and outlets are clear of debris etc.



NEVER clean by blowing air inwards.

Cooling Fan Drive

Periodically check that the fan mounting bolts in the fan hub have not loosened. If, for any reason, it becomes necessary to remove the fan or re-tighten the fan mounting bolts, apply a good grade of commercially available thread locking compound to the bolt threads and tighten to the torque value shown in the “*Torque Values*” table later in this section.

The fan belt(s) should be checked regularly for wear and correct tensioning.

Fuel System

The fuel tank should be filled daily or every eight hours. To minimise condensation in the fuel tank(s), it is advisable to top up after the machine is shut down or at the end of each working day. At six month intervals drain any sediment or condensate that may have accumulated in the tank(s).

Fuel Filter Water Separator

If the fuel filter water separator contains a filter element it should be replaced at regular intervals (see the “*Maintenance Schedule*”).

Hoses

All components of the engine cooling air intake system should be checked periodically to keep the engine at peak efficiency.

At the recommended intervals, (see the “*Maintenance Schedule*”), inspect all of the intake lines to the air filter, and all flexible hoses used for air lines, oil lines and fuel lines.

Periodically inspect all pipework for cracks, leaks, etc. and replace immediately if damaged.

Electrical System

WARNING

Always disconnect the battery cables before performing any maintenance or service.

Inspect the safety shutdown system switches and the instrument panel relay contacts for evidence of arcing and pitting. Clean where necessary.

Check the mechanical action of the components.

Check the security of electrical terminals on the switches and relays i.e. nuts or screws loose, which may cause local hot spot oxidation.

Inspect the components and wiring for signs of overheating i.e. discolouration, charring of cables, deformation of parts, acrid smells and blistered paint.

Battery

Keep the battery terminals and cable clamps clean and lightly coated with petroleum jelly to prevent corrosion.

The retaining clamp should be kept tight enough to prevent the battery from moving.

Pressure System

At 500 hour intervals it is necessary to inspect the external surfaces of the system (from the airend through to the discharge valve(s)) including hoses, tubes, tube fittings and the separator tank, for visible signs of impact damage, excessive corrosion, abrasion, tightness and chafing. Any suspect parts should be replaced before the machine is put back into service.

Tyres/Tyre Pressure

See the *“General Information”* section of this manual.

Running Gear/Wheels

Check the wheel nut torque 20 miles (30 kilometres) after refitting the wheels. Refer to the *“Torque Values”* table later in this section.

Lifting jacks should only be used under the axle.

The bolts securing the running gear to the chassis should be checked periodically for tightness (refer to the *“Maintenance Schedule”* for frequency) and re-tightened where necessary. Refer to the *“Torque Values”* table later in this section.

Brakes

Check and adjust the brake linkage at 500 miles (850 Km) then every 3000 miles (5000 Km) or 3 months (whichever is the sooner) to compensate for any stretch of the adjustable cables. Check and adjust the wheel brakes to compensate for wear.

Adjusting the Overrun Braking System (Knott Running Gear)

Preparation

Jack up the machine

Disengage the handbrake lever [1].

Fully extend the draw bar [2] on the overrun braking system.

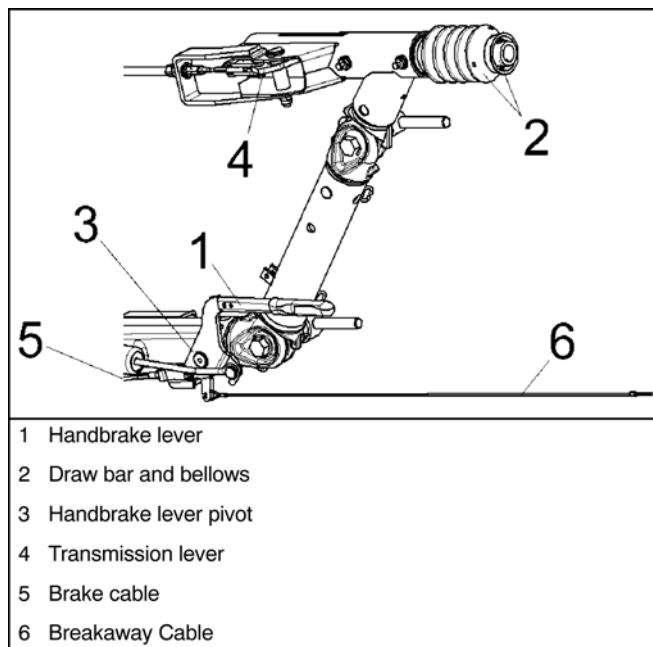

Requirements

During the adjustment procedure always start with the wheel brakes.

Always rotate the wheel in the direction of forward movement.

Ensure that an M10 safety screw is fitted to the handbrake pivot.

The brake actuators must not be pre-tensioned - if necessary loosen the brake linkage [7] on the brake equalisation assembly [8].

Check that brake actuators and cables [11] operate smoothly.

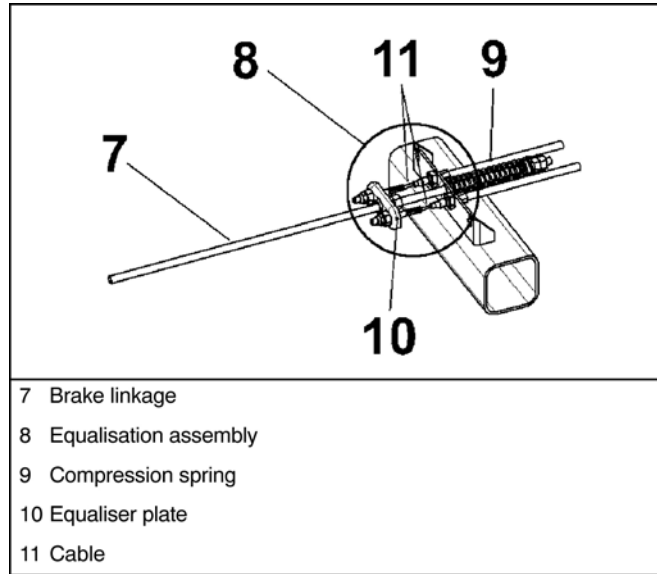

⚠ CAUTION

The compression spring [9] must only be lightly pre-tensioned and when operating must never touch the axle tube.

Never adjust the brakes at the brake linkage [7].

Brake Shoe Adjustment

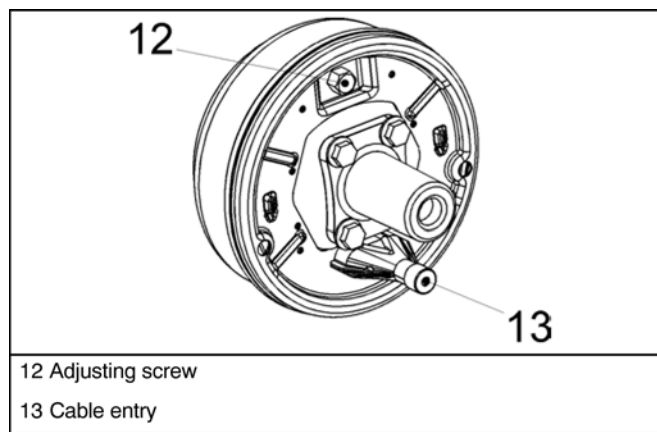

Width across flats of adjusting screw [12]

Brake size
160 X 35 / 200 X 50
250 X 40
300 X 60

Key width
SW 17
SW 19
SW 22

Tighten adjusting screw [12] clockwise until the wheel locks.

Loosen adjusting screw [12] anti-clockwise (approx. ½ turn) until the wheel can be moved freely.

Slight dragging noises that do not impede the free movement of the wheel are permissible.

This adjustment procedure must be carried out as described on both wheel brakes.

When the brake has been adjusted accurately the actuating distance is approximately 5-8mm on the cable [11]

Compensator Assembly Adjustment

Variable Height models

Fit an M10 safety screw to the handbrake pivot.

Disconnect the handbrake cable [5] at one end.

Pre-adjust brake linkage [7] lengthways (a little play is permissible) and re-insert the cable [5], adjusting it to give a small amount of play.

Remove the M10 safety screw from the handbrake pivot.

All Models

Engage the handbrake lever [1] and check that the position of the equaliser plate [10] is at right angles to the pulling direction. If necessary correct the position of the equaliser plate [10] on the cables [11].

The compression spring [9] must only be slightly pre-tensioned and when engaged must not touch the axle tube.

Brake Linkage Adjustment

Adjust the brake linkage [7] lengthways without pre-tension and without play in the transmission lever [4].

Readjustment

Engage the handbrake lever [1] forcefully a number of times to set the brake.

Check the alignment of the equalisation assembly [8], this should be at right angles to the pulling direction.

Check the play in the brake linkage [7].

If necessary adjust the brake linkage [7] again without play and without pre-tensioning.

There must still be a little play in cable [5] (Variable Height Only).

Check the position of the hand brake lever [1]. The start of resistance should be approximately 10-15mm above the horizontal position.

Check that the wheels move freely when the handbrake is disengaged.

Final Test

Check the fastenings on the transmission system (cables, brake equalisation system and linkage).

Check the handbrake cable [5] for a small amount of play and adjust if necessary (Variable height only).

Check the compression spring [9] for pre-tensioning.

Test Run

If necessary carry out 2-3 test brake actions.

Test brake action

Check the play in brake linkage [7] and if necessary adjust the length of brake linkage [7] until there is no play.

Apply the handbrake while rolling the machine forward, travel of the handbrake lever up to 2/3 of maximum is allowed.

Re-adjusting the Overrun Braking System (Knott Running Gear)

Re-adjustment of the wheel brakes will compensate for brake lining wear. Follow the procedure described in 2: Brake Shoe Adjustment.

Check the play in the brake linkage [7] and re-adjust if necessary.

NOTE: Check the brake actuators and cables [11]. The brake actuators must not be pre-tensioned.

Excessive operation of the handbrake lever, which may have been caused by worn brake linings, must not be corrected by re-adjusting (shortening) the brake linkage [7].

Re-adjustment

The handbrake lever [1] should be engaged forcefully several times to set the braking system.

Check the setting of the brake equalisation assembly [8], which should be at right angles to the pulling direction.

Check the play in the brake linkage [7] again, ensuring that there is no play in the brake linkage and that it is adjusted without pre-tension.

Check the position of the hand brake lever [1], cable [5] (with little play) and the compression spring [9] (only slight pre-tension). The start of resistance of the handbrake lever should be approximately 10-15mm above the horizontal position.

Final test

Check the fastenings on the transmission system (cables, brake equalisation system and linkage).

Apply the handbrake while rolling the machine forward, travel of the handbrake lever up to 2/3 of maximum is allowed.

Check the handbrake cable [5] for a small amount of play and adjust if necessary (Variable height only).

Check the compression spring [9] for slight pre-tensioning.

**CAUTION**

Check the wheel nut torque 20 miles (30 kilometres) after refitting the wheels (Refer to the “Torque Values” table later in this section).

Lubrication

The engine is initially supplied with engine oil sufficient for a nominal period of operation (for more information, consult the Engine section of this manual).

**CAUTION**

Always check the oil levels before a new machine is put into service.

If, for any reason, the unit has been drained, it must be re-filled with new oil before it is put into operation.

Engine Lubricating Oil

The engine oil should be changed at the engine manufacturer's recommended intervals. Refer to the “*Engine*” section of this manual.

Engine Lubricating Oil Specification

Refer to the “*Engine*” section of this manual.

Engine Oil Filter Element

The engine oil filter element should be changed at the engine manufacturer's recommended intervals. Refer to the “*Engine*” section of this manual.

Compressor Lubricating Oil

Refer to the “*Maintenance Schedule*” in this section for service intervals.

NOTE: If the machine has been operating under adverse conditions, or has suffered long shutdown periods, then more frequent service intervals will be required.

WARNING

DO NOT, under any circumstances, remove any drain plugs or the oil filler plug from the compressor lubricating and cooling system without first making sure that the machine is stopped and the system has been completely relieved of all air pressure (refer to “*Stopping the Machine*” in the “*Operating Instructions*” section of this manual).

Completely drain the receiver/separator system including the piping and oil cooler by removing the drain plug(s) and collecting the used oil in a suitable container.

Replace the drain plug(s) ensuring that each one is secure.

NOTE: If the oil is drained immediately after the machine has been running, then most of the sediment will be in suspension and will therefore drain more readily.

CAUTION

Some oil mixtures are incompatible and result in the formation of varnishes, shellacs or lacquers which may be insoluble.

NOTE: Always specify INGERSOLL RAND Pro-Tec™ oil for use at all ambient temperatures above -23° C.

Compressor Oil Filter Element

Refer to the “*Maintenance Schedule*” in this section for service intervals.

Running Gear Wheel Bearings

Wheel bearings should be packed with grease every 6 months. The type of grease used should conform to specification MIL-G-10924.

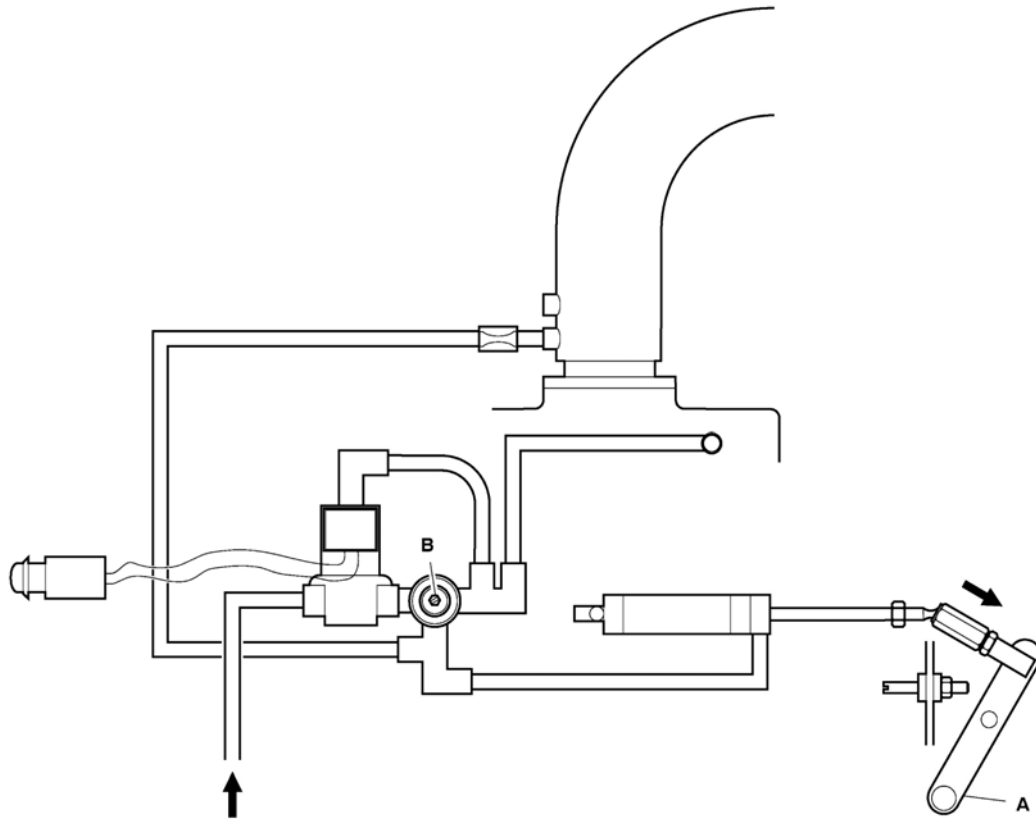

Speed and Pressure Regulation Adjustment

Normally, regulation requires no adjusting, but if correct adjustment is lost, proceed as follows:

Refer to the diagram above.

- A. Throttle arm
- B. Adjusting screw

Start the machine (Refer to “Starting the Machine” in the “Operating Instructions” section of this manual).

Inspect the throttle arm on the engine governor to see that it is extended in the full speed position when the engine is running at full-load speed and the service valve is fully open. (Refer to the “General Information” section of this manual).

Adjust the service valve on the outside of the machine to maintain 7 bar without the throttle arm moving from the full speed position. If the throttle arm moves away from the full speed position before 7 bar is attained, then turn the adjusting screw clockwise to increase the pressure. Optimum adjustment is achieved when the throttle arm just moves from its full speed position and the pressure gauge reads 7.2 bar.

Close the service valve. The engine will slow to idle speed.



Never allow the idle pressure to exceed 8.6 bar on the pressure gauge, otherwise the safety valve will operate.

Torque Values

	ft. lbf.	Nm.
Airend to engine	29 - 35	39 - 47
Air filter to bracket	16 - 20	22 - 27
Autella clamp to exhaust	9 - 11	12 - 15
Baffle to frame	9 - 11	12 - 15
Blowdown solenoid valve	21 - 26	28 - 35
Discharge manifold to frame	29 - 35	39 - 47
Drive pins to engine flywheel	57 - 69	77 - 93
Drop Leg	53 - 63	72 - 85
Engine/airend to chassis	54 - 58	73 - 78
Euro-Loc adaptor to separator tank	58 - 67	78 - 91
Exhaust flange to manifold	17 - 21	23 - 28
Fan guard	9 - 11	12 - 15
Fan to hub	12 - 15	16 - 20
Lifting bail bracket to engine	29 - 35	39 - 47
Oil pipe (-12jic)	71 - 88	96 - 119
Radiator/Cooler to baffle	9 - 11	12 - 15
Running gear front to chassis	63 - 69	82 - 93
Running gear rear to chassis	63 - 69	82 - 93
Running gear drawbar to axle	29 - 35	39 - 47
Separator tank cover	40 - 50	54 - 68
Separator tank to frame	18 - 22	24 - 30
Service pipe (-20jic)	106 - 133	143 - 180
Sight glass	40 - 50	54 - 68
Wheel nuts	62 - 70	85 - 95

Compressor Lubrication

Portable Compressor Fluid Chart

Refer to these charts for correct compressor fluid required. Note that the selection of fluid is dependent on the design operating pressure of the machine and the ambient temperature expected to be encountered before the next oil change.

Design Operating Pressure	Ambient Temperature	Specification
100 psi to 300 psi	-10° F to 125° F (-23° C to 52° C)	IR Pro-Tec™ Mil-PRF 2104G SAE 10W
100 psi to 300 psi	-40° F to 125° F (-40° C to 52° C)	IR Performance 500 Mil-L-46167
350 psi	-10° F to 125° F (-23° C to 52° C) 65° F to 125° F (18° C to 52° C) -40° F to 65° F (-40° C to 18° C)	IR XHP 505 IR XHP1001 IR Performance 500 Mil-L-46167
500 psi	50° F to 125° F (10° C to 52° C) 10° F to 65° F (-12° C to 18° C) below 10° F (-12° C)	IR XHP1001 IR XHP 505 Consult Factory

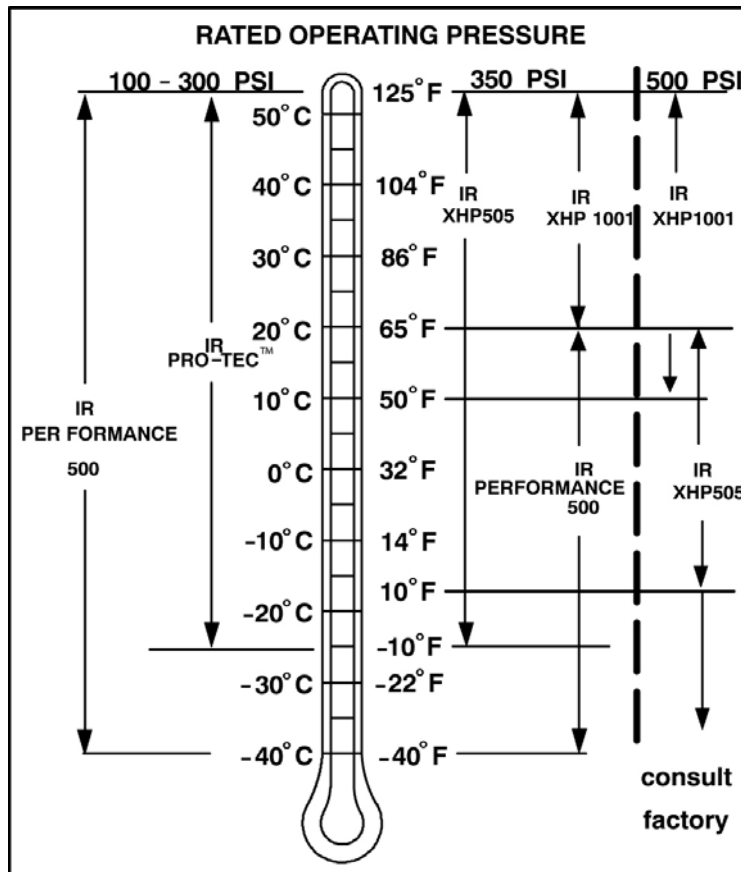

Recommended Ingersoll Rand Fluids - Use of these fluids with original IR filters can extend airtend warranty. Refer to operator's manual "Warranty" section for details or contact your IR representative.

Recommended Fluid	3.8 Litres	19.0 Litres	208.2 Litres
IR Pro-Tec™	36899698	36899706	36899714
IR XHP 505		35365188	35365170
IR Performance 500	35382928	35382936	35382944
IR XHP1001		35612738	35300516



Electrical System

Electrical System

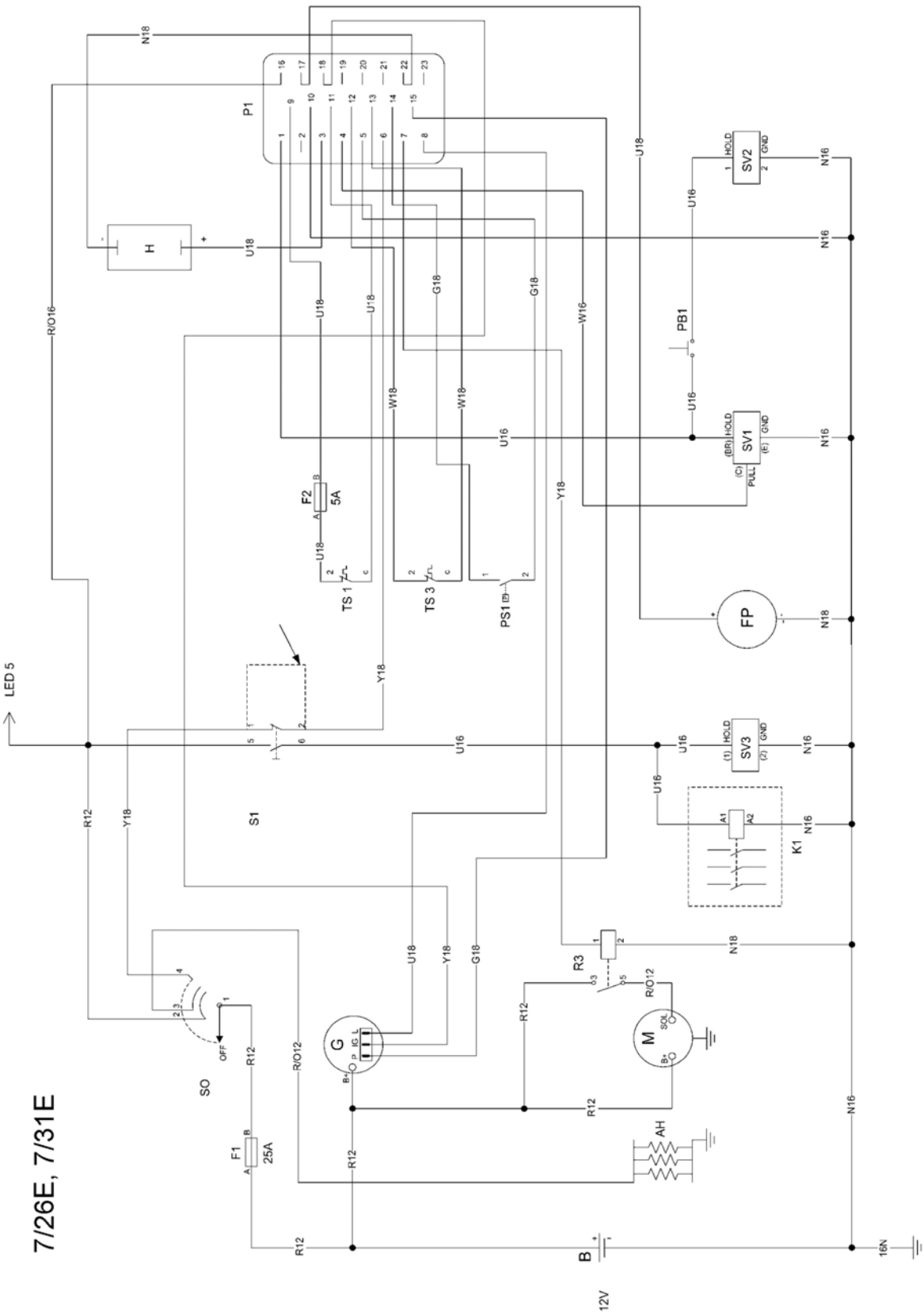

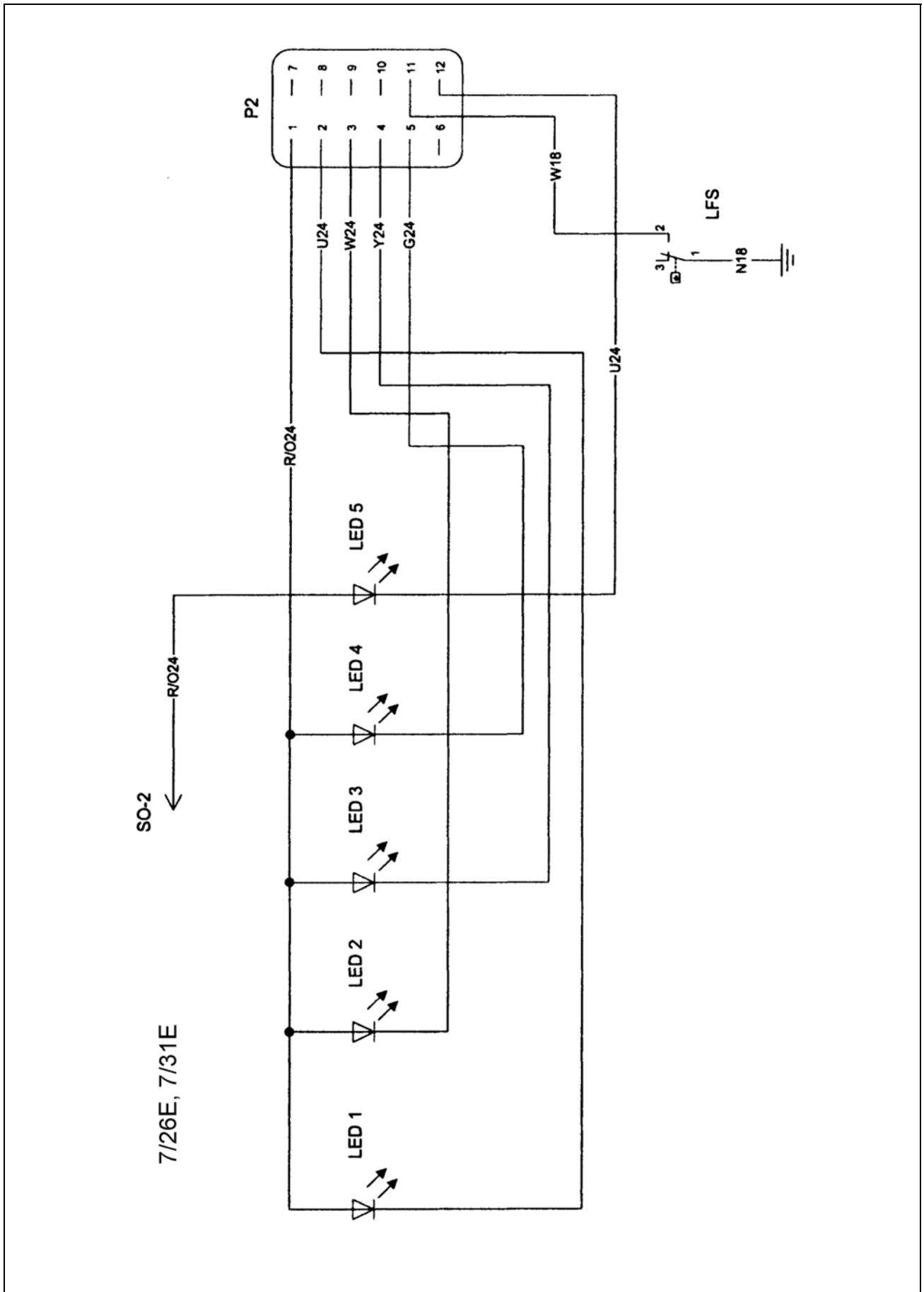

KEY

B	Battery 12V	P2	Connector, minicontroller (Option)
F1	Fuse 25A	LED 1	High air temperature, airend
F2	Fuse 5A	LED 2	High water temperature, engine
G	Alternator 12V	LED 3	Low oil pressure, engine
AH	Air heater	LED 4	Low fuel
H	Hourmeter	LED 5	No charge
M	Starter motor	FP	Fuel pump
PB1	Pushbutton, load/unload (Option)	S1	Switch, generator (Option)
PS1	Engine oil pressure switch	LFS	Switch, low fuel (Option)
R3	Relay, crank	P1	Connector, minicontroller
SO	Key - switch	P2	Connector, minicontroller (Option)
SV1	Solenoid, fuel	B	Black
SV2	Solenoid, load/unload (Option)	G	Green
SV3	Solenoid, generator (Option)	N	Brown
TS1	High air temperature switch (airend)	O	Orange
TS3	High water temperature switch (engine)	R	Red
FP	Fuel pump	U	Blue
S1	Switch, generator (Option)	W	White
LFS	Switch, low fuel (Option)	Y	Yellow
P1	Connector, minicontroller		

7/41

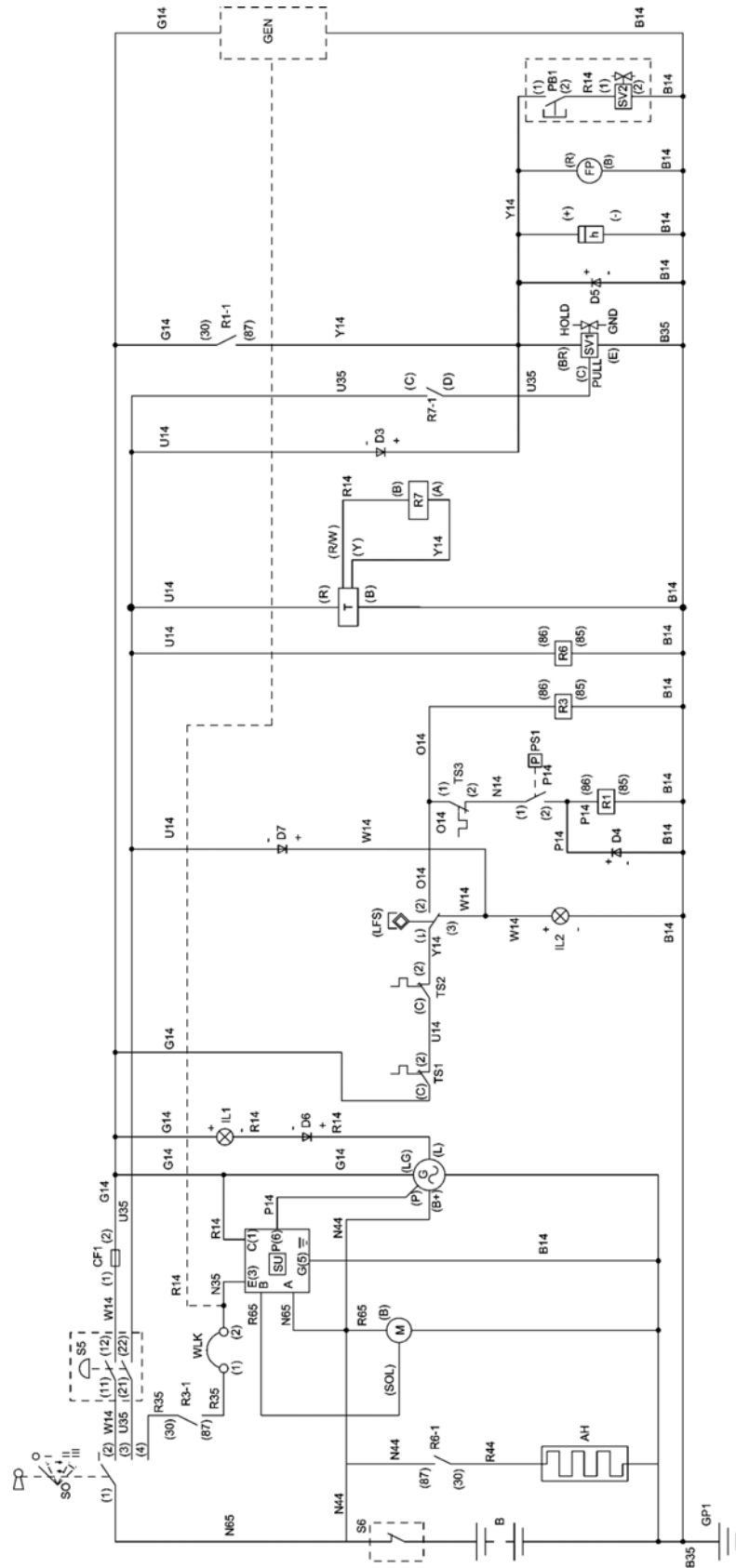

KEY

B Battery 12V	TS1 High air temperature switch (airend)
CF1 Control fuse 5A	TS2 High air temperature switch (discharge) (Option)
D1-7 Diode, blocking	TS3 High water temperature switch (engine)
G Alternator 12V	WLK Link
GEN Generator (Option)	T Timer
AH Air heater	SU Safety unit
h Hourmeter	FP Fuel pump
IL1 Lamp, No - charge	B Black
IL2 Lamp, low fuel	G Green
LFS Switch, low fuel level	K Pink
M Starter motor	LG Light green
PB1 Pushbutton, load/unload (Option)	N Brown
PS1 Engine oil pressure switch	O Orange
R1 Relay, control/shut-down	P Purple
R3 Relay, crank	R Red
R6 Relay, air heater	S Grey
R7 Relay, fuel solenoid	U Blue
SO Key-switch	W White
SV1 Solenoid, fuel	Y Yellow
SV2 Solenoid, load/unload (Option)	

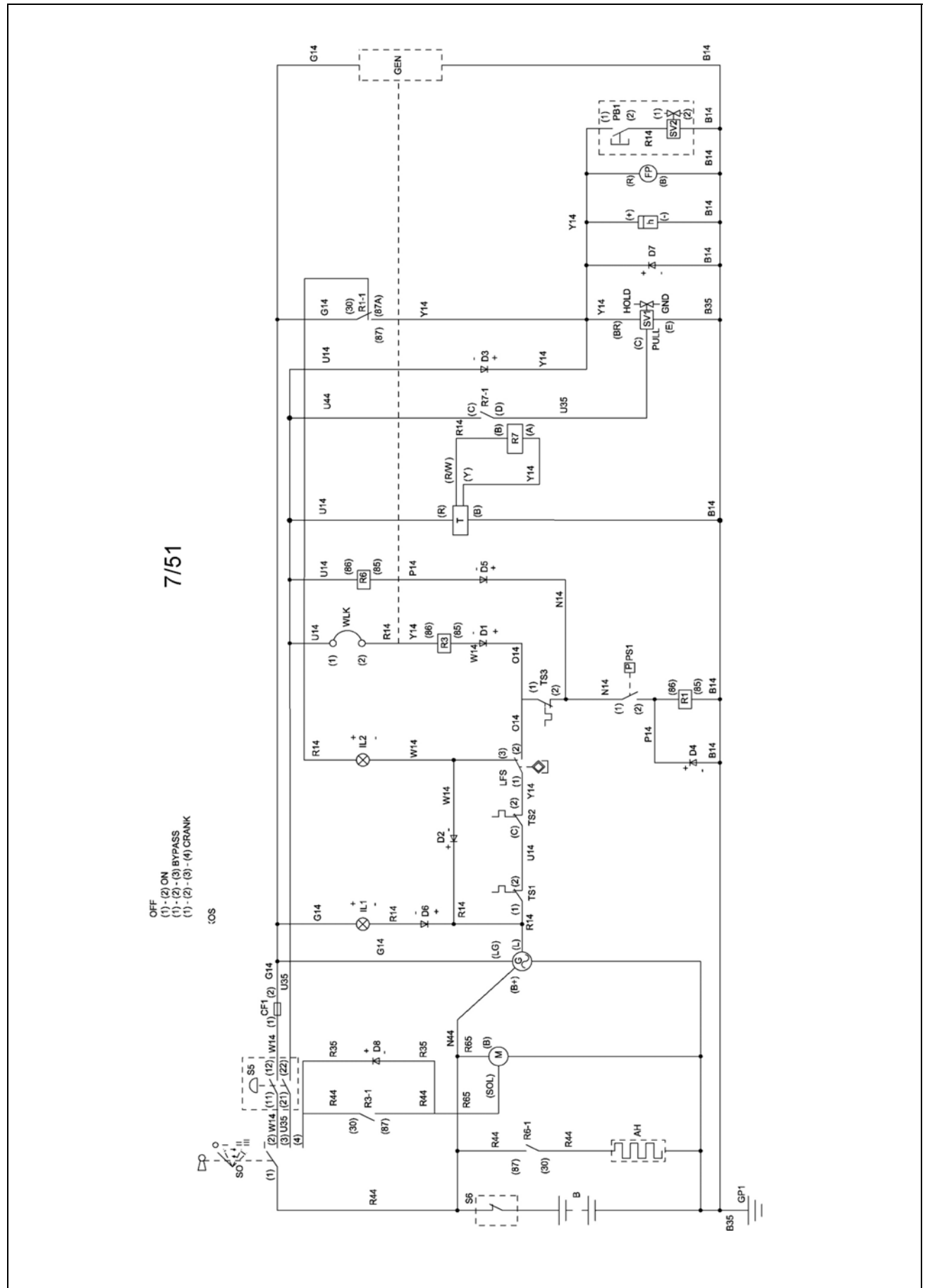

KEY

B	Battery 12V	SV2	Solenoid, load/unload (Option)
CF1	Control fuse 5A	TS1	High air temperature switch (airend)
D1-8	Diode, blocking	TS2	High air temperature switch (discharge) (Option)
G	Alternator 12V	TS3	High water temperature switch (engine)
GEN	Generator (Option)	WLK	Link
AH	Air heater	T	Timer
h	Hourmeter	FP	Fuel pump
IL1	Lamp, No - charge	B	Black
IL2	Lamp, low fuel	G	Green
LFS	Switch, low fuel level	K	Pink
M	Starter motor	LG	Light green
PB1	Pushbutton, load/unload (Option)	N	Brown
PS1	Engine oil pressure switch	O	Orange
R1	Relay, safety shut - down (24V)	P	Purple
R3	Relay, start inhibit (24V)	R	Red
R6	Relay, glowplug	S	Grey
R7	Relay, fuel solenoid	U	Blue
SO	Key - switch	W	White
SV1	Solenoid, fuel	Y	Yellow

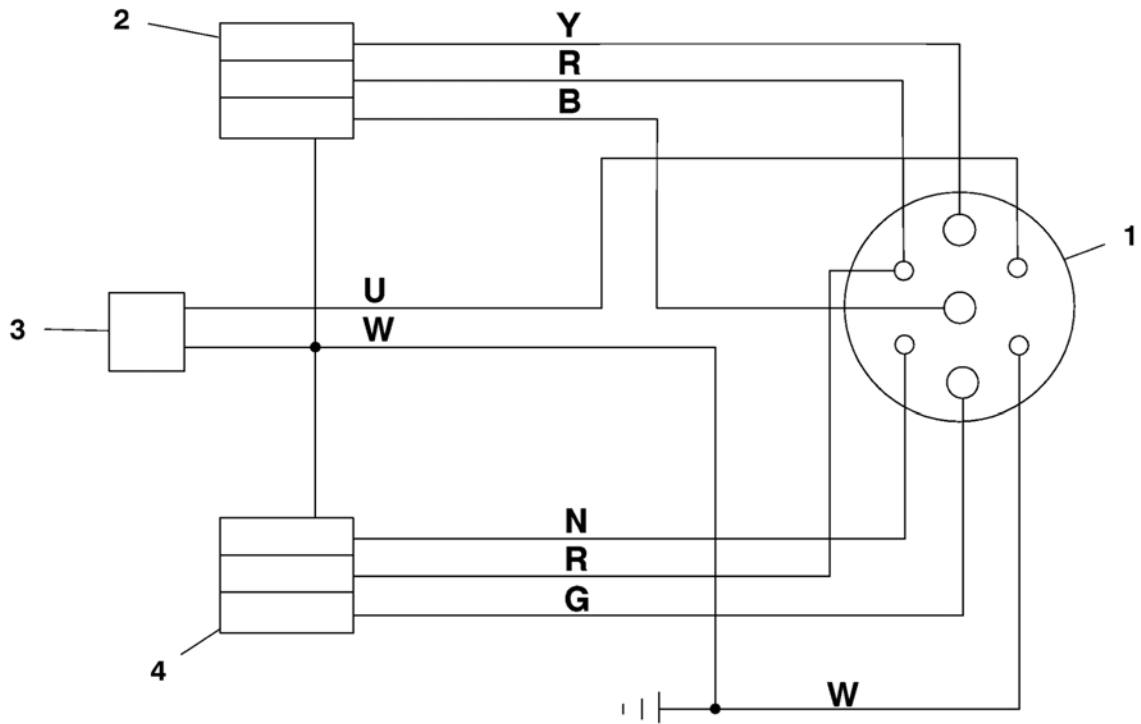

Schematic Diagram for European CE Lighting System

KEY

- | | |
|----------------------|----------|
| 1 Plug | O Orange |
| 2 Light (right hand) | P Purple |
| 3 Fog light | R Red |
| 4 Light (left hand) | S Grey |
| B Black | U Blue |
| G Green | W White |
| K Pink | Y Yellow |
| N Brown | |

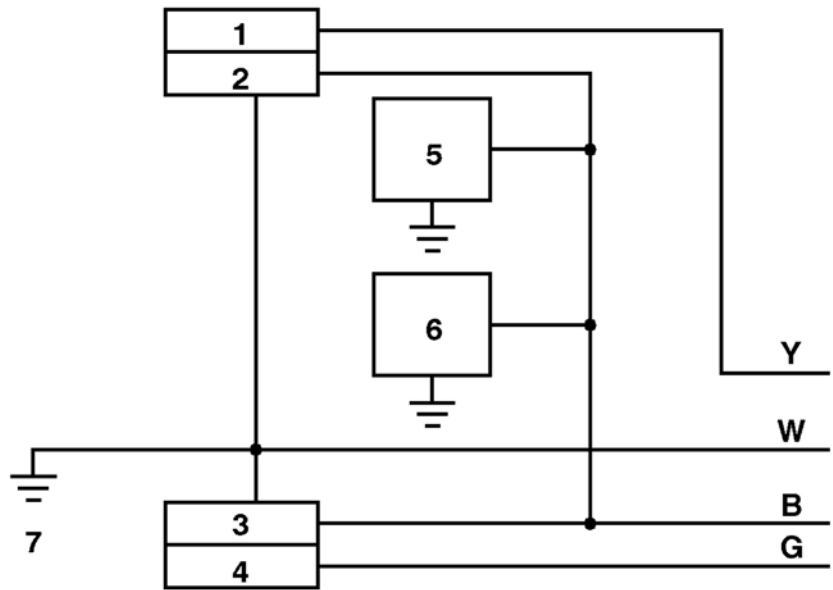

Schematic Diagram for American SAE Lighting System

KEY

- | | |
|---|-----------------|
| 1 Stop/turn (left hand) | K Pink |
| 2 Tail (left hand) | N Brown |
| 3 Stop/turn (right hand) | O Orange |
| 4 Tail (right hand) | P Purple |
| 5 Front side marker (left hand) | R Red |
| 6 Front side marker (right hand) | S Grey |
| 7 Ground/earth | U Blue |
| B Black | W White |
| G Green | Y Yellow |



Piping and Instrumentation System

Piping and Instrumentation System

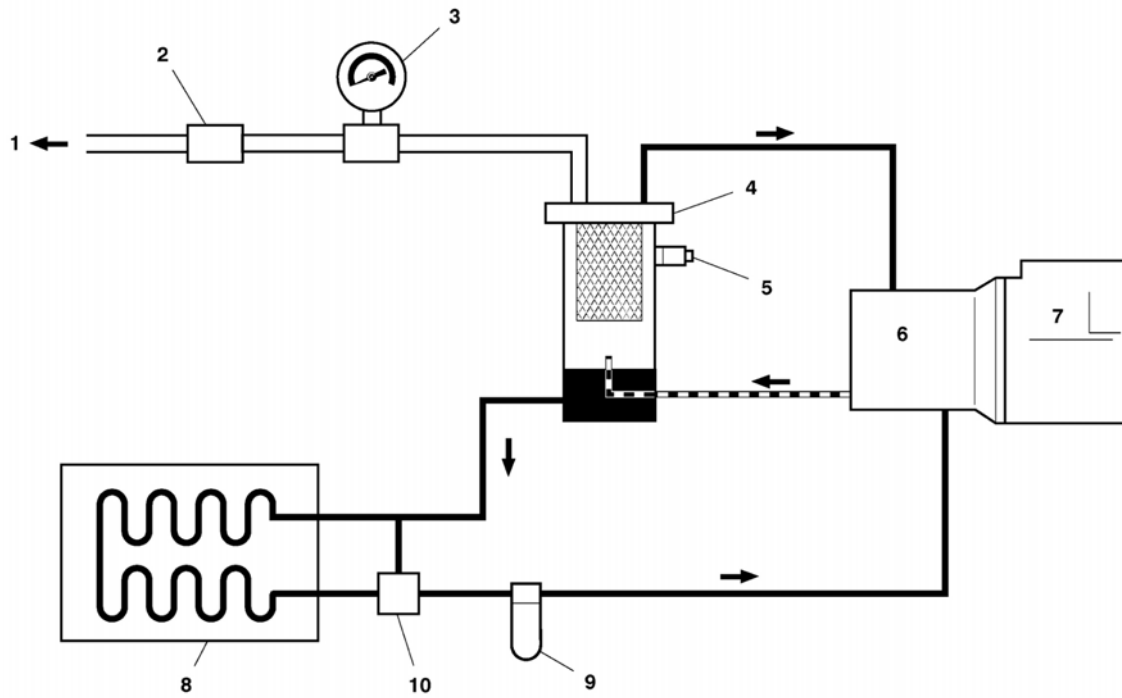

KEY

- | | |
|-----------------------------------|---------------------------------------|
| 1. Air discharge | 6. Compressor |
| 2. Sonic orifice (restricts flow) | 7. Engine |
| 3. Pressure gauge | 8. Oil cooler |
| 4. Separator tank | 9. Oil filter |
| 5. Safety valve | 10. Thermostatic valve (Where fitted) |

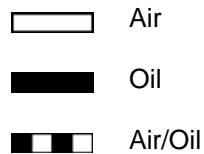



Fault Finding

Fault Finding

Fault	Cause	Remedy
Engine fails to start.	<i>Low battery charge.</i>	Check the fan belt tension, battery and cable connections.
	<i>Bad earth connection.</i>	Check the earth cables, clean as required.
	<i>Loose connection.</i>	Locate and make the connection good.
	<i>Fuel starvation.</i>	Check the fuel level and fuel system components. Replace the fuel filter if necessary.
	<i>Relay failed.</i>	Replace the relay.
	<i>Engine control not in 'run' position.</i>	Check the speed cylinder and stop position.
Engine starts but stalls when the switch returns to position I.	<i>Electrical fault</i>	Test the electrical circuits.
	<i>Low engine oil pressure.</i>	Check the oil level and the oil filter(s).
	<i>Faulty relay</i>	Check the relays.
	<i>Faulty key-switch.</i>	Check the key-switch.
Engine starts but will not run or engine shuts down prematurely.	<i>Electrical fault.</i>	Test the electrical circuits.
	<i>Low engine oil pressure.</i>	Check the oil level and oil filter(s).
	<i>Safety shut-down system in operation.</i>	Check the safety shut-down switches.
	<i>Fuel starvation.</i>	Check the fuel level and fuel system components. Replace the fuel filter if necessary.
	<i>Switch failure.</i>	Test the switches.
	<i>High compressor oil temperature.</i>	Check the compressor oil level and oil cooler. Check the fan drive.
	<i>Water present in fuel system.</i>	Check the water separator and clean if required.
	<i>Faulty relay.</i>	Check the relay in the holder and replace if necessary.
Engine Overheats.	<i>Reduced cooling air from fan.</i>	Check the fan and the drive belts. Check for any obstruction inside the cowl.

Fault	Cause	Remedy
Engine speed too high.	<i>Incorrect throttle arm setting.</i>	Check the engine speed setting.
	<i>Faulty regulator valve.</i>	Check the regulation system.
Engine speed too low.	<i>Incorrect throttle arm setting.</i>	Check the throttle setting.
	<i>Blocked fuel filter.</i>	Check and replace if necessary.
	<i>Blocked air filter.</i>	Check and replace the element if necessary.
	<i>Faulty regulator valve.</i>	Check the regulation system.
	<i>Premature unloading.</i>	Check the regulation and the operation of the air cylinder.
Excessive vibration.	<i>Engine speed too low.</i>	See "Engine speed too low"
Refer also to the "Engine" section of this manual.		
Air discharge capacity too low.	<i>Engine speed too low.</i>	Check the air cylinder and air filter(s).
	<i>Blocked air cleaner.</i>	Check the restriction indicators and replace the element(s) if necessary.
	<i>High pressure air escaping.</i>	Check for leaks.
	<i>Incorrectly set regulation system.</i>	Reset the regulation system. Refer to "Speed and Pressure Regulation Adjustment" in the "Maintenance" section of this manual.
Compressor overheats.	<i>Low oil level.</i>	Top up the oil level and check for leaks.
	<i>Dirty or blocked oil cooler.</i>	Clean the oil cooler fins.
	<i>Incorrect grade of oil.</i>	Use Ingersoll Rand recommended oil.
	<i>Recirculation of cooling air.</i>	Move the machine to avoid recirculation.
	<i>Faulty temperature switch.</i>	Check the operation of the switch and replace if necessary.
	<i>Reduced cooling air from fan.</i>	Check the fan and the drive belts. Check for any obstruction inside the fan cowl.

Fault	Cause	Remedy
Excessive oil present in the discharge air.	<i>Blocked scavenge line.</i>	Check the scavenge line, drop tube and orifice. Clean and replace.
	<i>Perforated separator element.</i>	Replace the separator element.
	<i>Pressure in the system is too low.</i>	Check the minimum pressure valve or sonic orifice.
Safety valve operates.	<i>Operating pressure too high.</i>	Check the setting and operation of the regulator valve piping.
	<i>Incorrect setting of the regulator.</i>	Adjust the regulator.
	<i>Faulty regulator.</i>	Replace the regulator.
	<i>Inlet valve set incorrectly.</i>	Refer to “Speed and Pressure Regulation Adjustment” in the “Maintenance” section of this manual.
	<i>Loose pipe/hose connections.</i>	Check all pipe/hose connections.
	<i>Faulty safety valve.</i>	Check the relieving pressure. Replace the safety valve if faulty. DO NOT ATTEMPT A REPAIR.
Oil is forced back into the air filter.	<i>Incorrect stopping procedure used</i>	Always employ the correct stopping procedure. Close the discharge valve and allow the machine to run on idle before stopping.
	<i>Faulty inlet valve.</i>	Check for free operation of the inlet valve(s).
	<i>Faulty discharge check valve.</i>	Remove the valve from the discharge pipe and check the operation.
Machine goes to full pressure when started.	<i>Inlet valve set incorrectly.</i>	Refer to “Speed and Pressure Regulation Adjustment” in the “Maintenance” section of this manual.
Machine fails to load when the load button is pressed.	<i>Faulty load solenoid.</i>	Replace the solenoid. Check the electrical circuit by feeling for movement whilst depressing the load button.



Options

Options

Lubricator

Safety

WARNING

Ensure that the lubricator filler cap is re-tightened correctly after replenishing with oil.

Do not replenish the lubricator oil, or service the lubricator without first making sure that the machine is stopped and the system has been completely relieved of all air pressure (Refer to “*Stopping the Machine*” in the “*Operating Instructions*” section of this manual).

CAUTION

If the nylon tubes to the lubricator are disconnected then ensure that each tube is re-connected in its original location.

General Information

Oil capacity: 2 litres

Oil specification: Refer to the Tool Manufacturer’s Manual.

Operating Instructions

Commissioning

Check the lubricator oil level and fill as necessary.

Prior to Starting

Check the lubricator oil level and replenish as necessary.

Maintenance

Check the lubricator oil level and replenish as necessary.

Fault Finding

Fault	Cause	Remedy
No oil flow	Incorrect connection	Reverse the nylon tube connections to the lubricator

Generator (WDG)

Safety

Refer to the “Safety” section in this manual.

General Information

Rated output:	4.8 kW @ 0.8 Power factor (PF) lagging
Rated voltage:	110V 1ph or 230V 1ph or 230V 3ph or 400V 3ph + 230V 1ph @ 3000 revs min ⁻¹
Voltage regulation:	± 6%
Maximum continuous output:	6 kVA @ 0.8 PF
Rotor type:	Brushless (110/230V 1ph)
Rotor type:	Rotating armature with sliprings (230V 3ph/400V 3ph + 230V 1ph)
De-rating factors at 0.8 pf continuous load:	
<i>Air in temp 20° C</i>	Continuous
<i>Air in temp 30° C</i>	5.7 KVA @ 0.8 p.f continuous
<i>Air in temp 46° C</i>	4.5 KVA @ 0.8 p.f continuous
De-rating factors for intermittent load:	
<i>Air in temp 20 - 35° C</i>	55 mins/hr @ 0.8, 5 mins off load
<i>Air in temp 35 - 40° C</i>	50 mins/hr @ 0.8, 10 mins off load
<i>Air in temp 40° C +</i>	45 mins/hr @ 0.8, 15 mins off load
Socket outlets:	
<i>110V 1ph & 230V 1ph</i>	1 X 32 amperes, 2 X 16 amperes
<i>230V 3ph</i>	1 X 16 amperes
<i>400V 3ph + 230V 1ph</i>	400V 3ph = 1 X 16 amperes, 230V 1ph = 2 X 16 amperes

Earth leakage protection is provided by a single residual current device. Miniature circuit breakers (MCB) are fitted to provide both overcurrent and short circuit protection for the generator.

Each socket outlet is protected by a spring loaded weather-proof cover.

Operating Instructions

A mode selector switch is provided to switch the machine between compressor and generator mode.



Do not start or stop the machine with the compressor/generator mode switch in the Generator position.

When the switch is in the Generator position the normally-open solenoid valve switches to the closed position and air in the line to the engine speed control cylinder vents to the atmosphere via the solenoid exhaust port. This causes the cylinder to move to its maximum speed position. The engine will now maintain maximum speed as the air line from the pressure regulator valve to the solenoid valve is now closed.

When the switch is returned to the Compressor position, the solenoid valve is de-energised thus returning it to its normally open position. The engine speed cylinder would then respond via the pressure regulator valve according to the air demand.

When connecting electrical equipment to any of the socket outlets, it is recommended that the appropriate MCB is in the OFF position before making the connection, switching the MCB to the ON position immediately prior to using the equipment.

Prior to Starting (Generator) (WDG)

If the generator should become exposed or saturated with moisture/water deposits, it must be safely dried off before attempting to make any part or conductor electrically live. This should be done by wiping away excess water, then running the engine with no electrical loads connected, until the generator is completely dry.

Ensure all persons concerned are suitably competent with electrical installations.

Ensure that there is a safe working procedure which has been issued by supervisory personnel, and that it is understood by all persons concerned with the operation of the generator.

Ensure that the safety procedure to be applied is based on the appropriate national regulations.

Ensure that the safety procedure is followed at all times.

Ensure that suitable guidance codes are available to indicate safe working practices, and any hazards to avoid.

Before starting the engine and switching in the generator load, ensure that :-

- The system has been inspected and earthed.
- No persons are in a hazardous position.
- Any warnings necessary have been suitably displayed (where applicable).

Ensure compressor/generator mode switch is set to compressor.

Starting the Machine

⚠ WARNING

Under no circumstances should volatile liquids such as Ether be used for starting this machine.

⚠ CAUTION

Do not start or stop the machine with the compressor/generator mode switch in the Generator position.

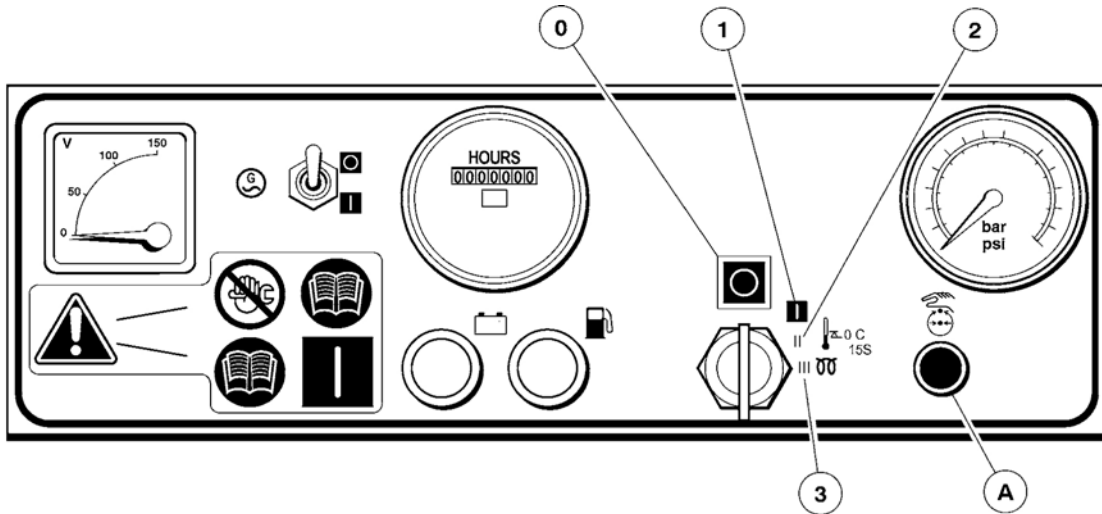

All normal starting functions are incorporated in the key operated switch.

- Turn the key switch to position **1**, the alternator charge light will illuminate.
- Turn the key switch to position **3** (engine start position).
- Release to position **2** when the engine starts.
- Release to position **1** when the alternator charge light is extinguished.

At temperatures below 0° C or if there is difficulty starting first time:

- Push and release button 'A'.
- Allow the engine to reach operating temperature.
- At this point in the operation of the machine it is safe to apply full load to the engine.

NOTE: Wear hearing protection at all times when the engine is started with the top open and air is flowing from the valve.

Stopping the Machine

1. Close the service valve.
2. Allow the machine to run unloaded for a short period of time to reduce the engine temperature.
3. Turn the start switch to the **0** (off) position.

NOTE: As soon as the engine stops, the automatic blowdown valve will relieve all pressure from the system.

If the automatic blowdown valve fails to operate, then pressure must be relieved from the system by means of the service valve(s).



Never allow the machine to stand idle with pressure in the system.

Emergency Stopping

In the event that the unit has to be stopped in an emergency, TURN THE KEY SWITCH LOCATED ON THE INSTRUMENT PANEL TO THE **0** (OFF) POSITION.

Re-Starting After an Emergency

If the machine has been switched off because of a machine malfunction, then identify and correct the fault before attempting to re-start.

If the machine has been switched off for reasons of safety, then ensure that the machine can be operated safely before re-starting.

Refer to the *"Prior to Starting"* and *"Starting the Machine"* instructions earlier in this section before re-starting the machine.

Monitoring During Operation

Should any of the safety shut-down conditions occur, the unit will stop. These are:

- Low engine oil pressure
- High air discharge temperature
- High engine oil temperature
- Alternator/drive belt failure circuit
- Low engine fuel level

A yellow rectangular box containing a black triangle with a white exclamation mark inside, followed by the word "CAUTION" in bold black capital letters.

To ensure an adequate flow of oil to the compressor at low temperature, never allow the discharge pressure to fall below 3.5 bar.

Decommissioning

When the machine is to be permanently decommissioned or dismantled, it is important to ensure that all hazard risks are either eliminated or notified to the recipient of the machine. In particular:-

- Do not destroy batteries or components containing asbestos without containing the materials safely.
- Do not dispose of any pressure vessel that is not clearly marked with its relevant data plate information or rendered unusable by drilling, cutting etc.
- Do not allow lubricants or coolants to be released into land surfaces or drains.
- Do not dispose of a complete machine without documentation relating to instructions for its use.

Maintenance

General

Ensure all electrical equipment is properly maintained and controlled.

Ensure all earth connections are secure and regularly maintained.

Earth Leakage Circuit Breaker (ELCB)

The earth leakage circuit breaker must be mechanically tested daily by pushing the test button with the machine in its no load condition. The ELCB should trip to the OFF (down) position.

The earth leakage circuit breaker should also be tested every 3 months. A proprietary test meter should be used to induce live to earth preset flow at each socket outlet. This current flow will produce the required earth fault check. The test should be conducted in accordance with appropriate national standards.

Instruments and Controls

A Voltmeter is provided to indicate the output voltage.

Miniature circuit breakers provide over-current protection. In the event of excess current the appropriate circuit breaker will trip to the OFF position

NOTE: The current trip rating is quoted at a nominal 40° C ambient temperature.

An earth leakage circuit breaker provides additional protection in the event of a leakage to earth in excess of 30 milliamperes on the connected appliance or in the connections to the generator.

For alternator maintenance refer to Mecc Alte operation and maintenance manual.

Fault Finding

Fault	Cause	Remedy
No output.	<i>Load plugs not fitted into socket outlets correctly.</i>	Ensure that the load plugs are fitted correctly into the socket outlets.
No output.	<i>Loose connection.</i>	Remove end cover and terminal box lid and check for loose connections. Rectify the fault as necessary.
	<i>Faulty rectifier.</i>	Check the rectifier bridge which is located inside the rear housing.
	<i>Faulty capacitor.</i>	Check the capacitors.
	<i>The No load voltage is low but increases when a load is applied.</i>	Check the capacitors and associated wiring.
	<i>The No load voltage falls when a load is applied.</i>	Check the capacitors and associated wiring.
	<i>Loss of residual magnetic field</i>	Refer to Mecc Alte maintenance manual
No output.	<i>Output winding(s) damaged.</i>	Measure the voltage across the winding(s). Replace the generator if damaged.
	<i>Field winding damaged.</i>	Replace the generator.
Generator fails to provide maximum output.	<i>Engine is not running at full speed.</i>	Check the engine speed with a tachometer. Consult Ingersoll Rand if the engine is found to be running slow (Refer to “General Information” section).
	<i>Drive belt is not tensioned correctly.</i>	Re-tension the drive belt.
	<i>Drive pulley is loose on the drive shaft.</i>	Check the drive pulley and tighten as required.

Fault	Cause	Remedy
The output voltage collapses when a load is connected	<i>Overload condition.</i>	Check and reset each circuit breaker. If the condition persists then investigate the cause and rectify the fault as necessary. (see also 'Circuit breaker trips')
	<i>Short circuit.</i>	Check for a short circuit and rectify the fault as necessary.
	<i>Incorrect wiring.</i>	Check the wiring and rectify the fault as necessary.
Circuit breaker trips.	<i>Overload condition.</i>	Check and reset each circuit breaker. If the condition persists then investigate the cause and rectify the fault as necessary. (see also 'Circuit breaker trips')
	<i>Short circuit.</i>	Check for a short circuit and rectify the fault as necessary.
	<i>Fault in appliance.</i>	Check the appliance and rectify the fault as necessary.
A circuit breaker fails to re-set whilst the machine running.	<i>Circuit breaker latching mechanism faulty.</i>	Repair or replace as necessary.
<i>Refer to Engine Manufacturer's manual and Mecc Alte manufacturer's manual</i>		

A.C. Electrical Power Schematic Diagram, 115V 1 - Phase

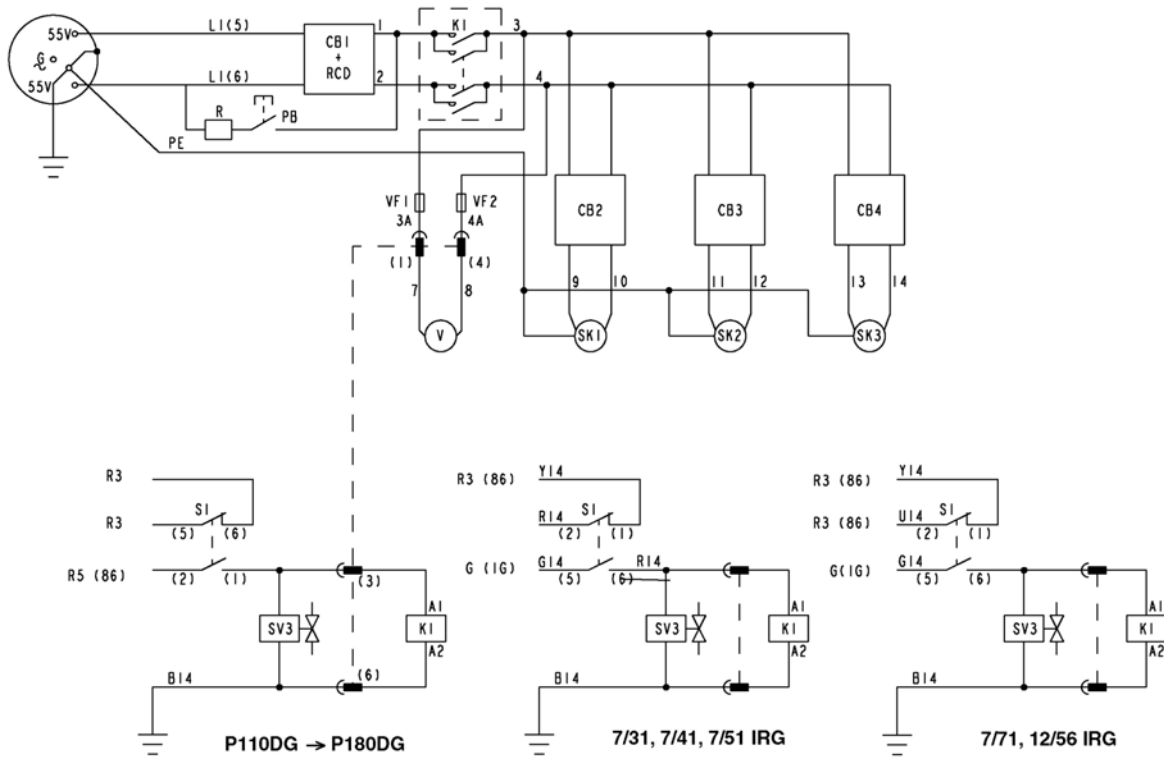

KEY

- | | |
|--------------------------------|------------------------------|
| CB1 Circuit breaker 63A | S1 Switch, start |
| CB2 Circuit breaker 32A | SK1 Socket outlet 32A |
| CB3 Circuit breaker 16A | SK2 Socket outlet 16A |
| CB4 Circuit breaker 16A | SK3 Socket outlet 16A |
| G Alternator | SV3 Valve, solenoid |
| K1 Contactor | V Voltmeter |
| PB Pushbutton | VF1 Fuse Voltmeter |
| R Resistor | VF2 Fuse Voltmeter |

A.C. Electrical Power Schematic Diagram, 230V 1 - Phase.

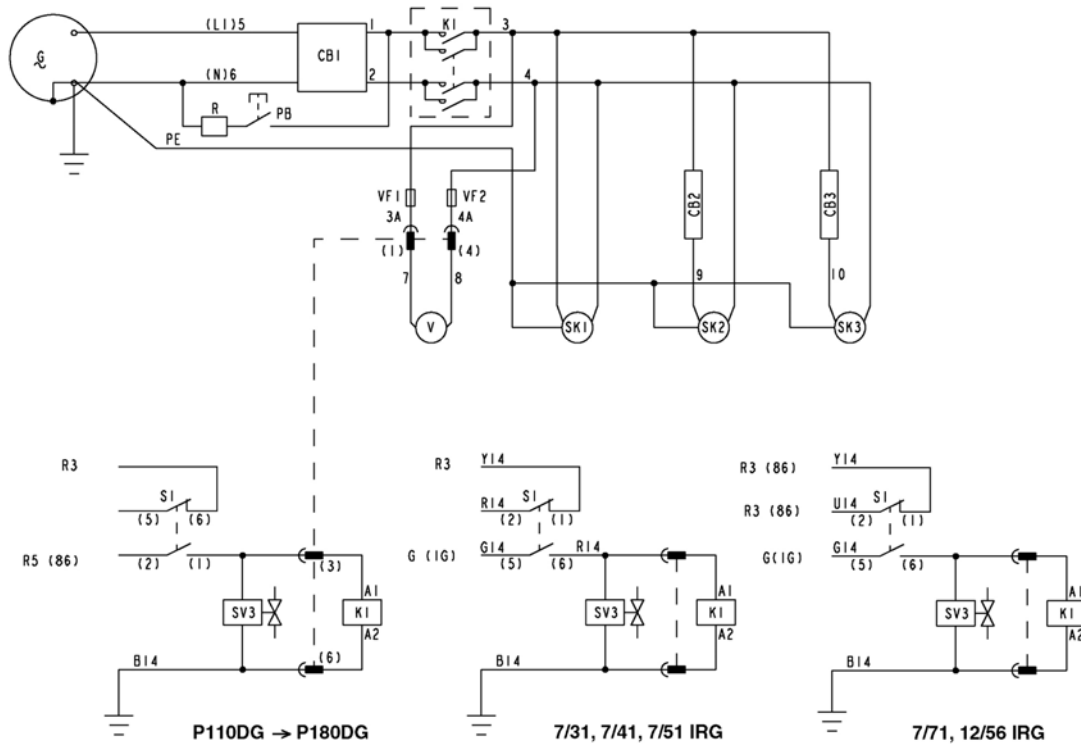

KEY

CB1	Circuit breaker 32A	S1	Switch, start
CB2	Circuit breaker 16A	SK1	Socket outlet 32A
CB3	Circuit breaker 16A	SK2	Socket outlet 16A
G	Alternator	SK3	Socket outlet 16A
K1	Contactor	SV3	Valve, solenoid
PB	Pushbutton	V	Voltmeter
R	Resistor	VF1	Fuse Voltmeter
		VF2	Fuse Voltmeter

A.C. Electrical Power Schematic Diagram, 400/230V 3 - Phase

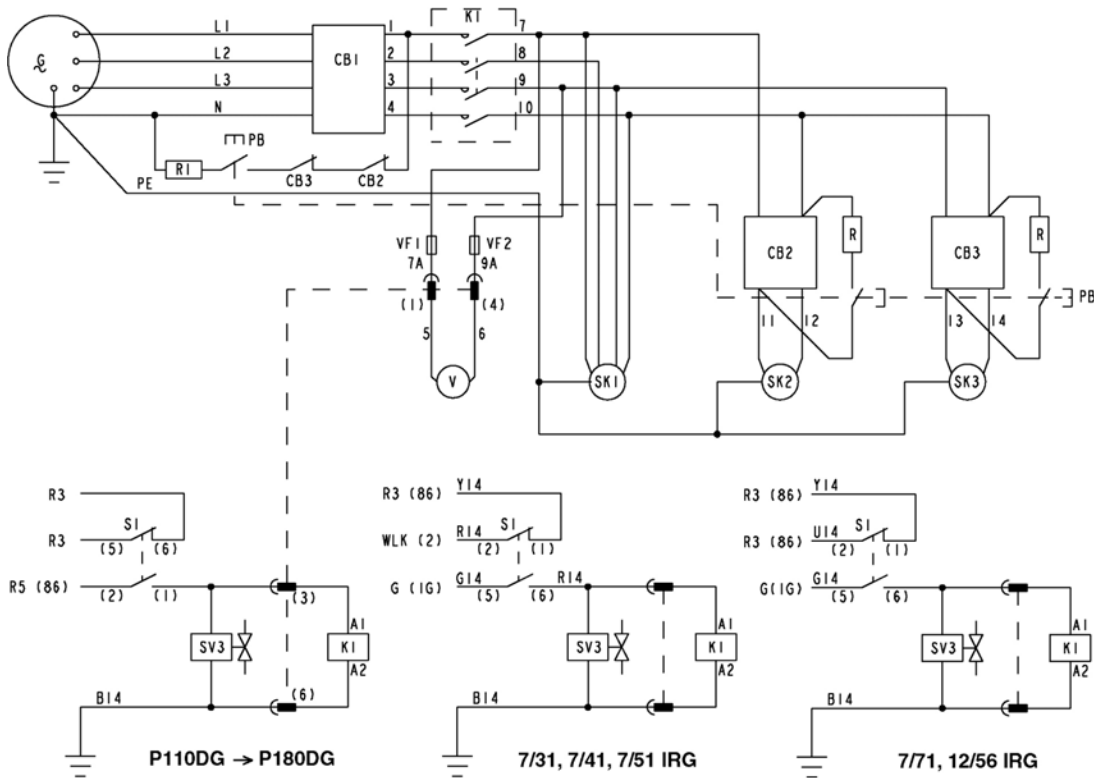

KEY

- | | |
|--------------------------------|------------------------------|
| CB1 Circuit breaker 16A | S1 Switch, start |
| CB2 Circuit breaker 10A | SK1 Socket outlet 16A |
| CB3 Circuit breaker 10A | SK2 Socket outlet 16A |
| G Alternator | SK3 Socket outlet 16A |
| K1 Contactor | SV3 Valve, solenoid |
| PB Pushbutton | V Voltmeter |
| R Resistor | VF1 Fuse Voltmeter |
| R1 Resistor | VF2 Fuse Voltmeter |



Engine

Engine - 3IRH2N, 3IRH8N, 4IRH8N & 4IRI8N

Foreword

The INGERSOLL RAND industrial diesel engines are a product of long years of experience, advanced technology, and up-to date production facilities. INGERSOLL RAND takes great pride in the superior durability and operating economy of these engines.

In order to get the fullest use and benefit from your engine, it is important that you operate and maintain it correctly. This Manual is designed to help you do this.

Please read this Manual carefully and follow its operating and maintenance recommendations. This will ensure many years of trouble-free and economical engine operation.

Should your engine require servicing, please contact your nearest INGERSOLL RAND branch or distributor.

All information, illustrations, and specifications contained in this Manual are based on the latest product information available at the time of publication.

INGERSOLL RAND reserves the right to make changes in this Manual at any time without prior notice.

This manual covers both 3 and 4 cylinder naturally aspirated engines.

The pictures contained within are for guidance only and might not reflect the physical characteristics of each individual engine covered.

Diesel Engine

Engine External View - Model

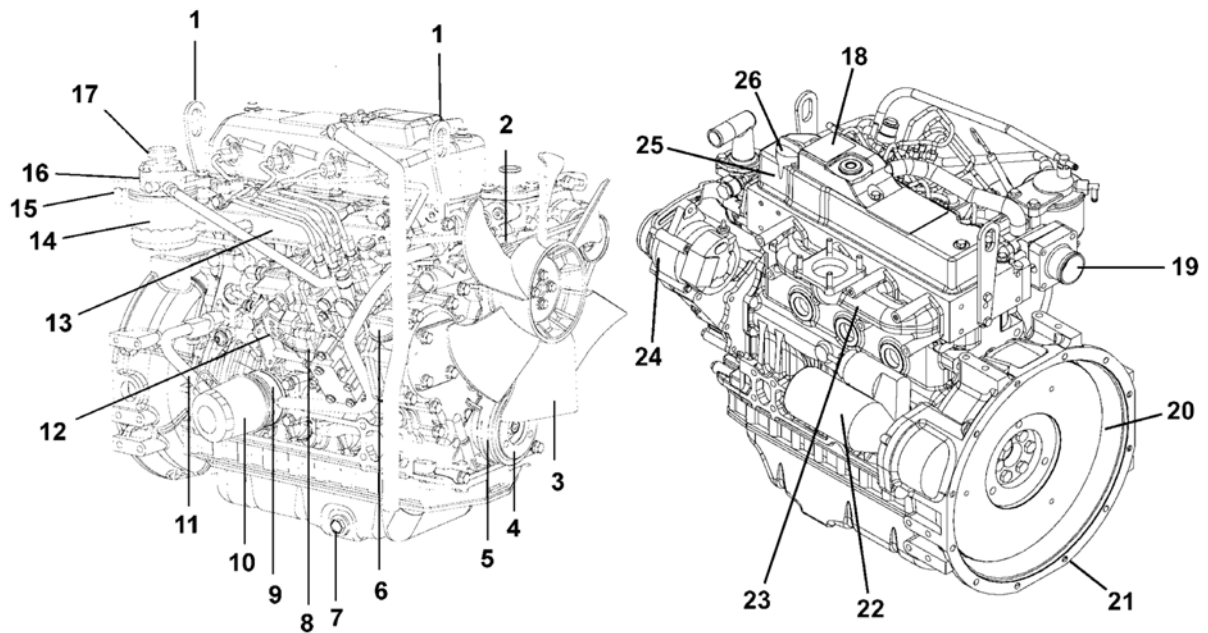

- | | |
|-------------------------------|---|
| 1. Lifting eye | 14. Fuel filter |
| 2. Cooling water pump | 15. Fuel oil inlet |
| 3. Cooling fan | 16. Fuel filter mounting with fuel priming pump |
| 4. Crank shaft V-pulley | 17. Fuel priming pump |
| 5. V-belt | 18. Engine name plate |
| 6. Filler port (engine oil) | 19. Air intake port |
| 7. Drain plug (engine oil) | 20. Flywheel |
| 8. Fuel injection pump | 21. Flywheel housing |
| 9. Engine oil cooler (4IRH8N) | 22. Starter motor |
| 10. Engine oil filter | 23. Exhaust manifold |
| 11. Dipstick (engine oil) | 24. Alternator |
| 12. Governor lever | 25. Rocker arm cover |
| 13. Intake manifold | 26. Filler port (engine oil) |

General Information

EPA Certified Engine Data and Specifications - 3IRH2N

Model: 3IRH2N		
Engine model name	3IRH2N	
Engine type	Vertical inline water cooled diesel engine	
Combustion type	Direct injection	
No. of cylinders - bore X stroke mm	3 - 82 X 84	
Engine displacement L	1.331	
Compression ratio	19.2:1	
Firing order	1 - 3 - 2	
Exhaust emission control system	Fuel injection nozzles, fuel injector pump	
Governor	Mechanical type	
Injection nozzles	Hole type	
Specified fuel	Diesel fuel (ISO 8217 DMA, BS2869 A1/A2)	
Starter (V-kW)	12 - 1.2	
Alternator (V-A)	12 - 40	
Specified engine oil (API grade) (SAE grade)	(CD, CF) (10W-30 or 15W-40)l	
Coolant volume (Engine only) L	1.8	
Engine dry weight kg	128	
Engine dimensions	Overall length mm	528
	Overall width mm	489
	Overall height mm	565
Valve clearance (cold) mm	0.2 ± 0.05	
Nozzle injection pressure MPa	21.6	
Injection timing B.T.D.C. at 2.5 mm cam lift	18° ±1	

Engine Identification

Serial No. Location

The engine serial number is stamped on engine name plate on top of rocker cover. See illustration on *Page - 119*.

Confirmation of Engine Number

It is advisable to quote the engine serial number together with the machine serial number, as it is required when you contact the Ingersoll Rand branch or distributor for repair, service or parts ordering.



Conduct confirmation of engine serial number with the engine stopped. To avoid being injured, do not check it, while the engine is still hot.

Ingersoll Rand Engine After Service

Please feel free to contact your Ingersoll Rand dealer for periodical inspection and maintenance.

Ingersoll Rand Genuine Parts

Genuine Ingersoll Rand parts are identical with those used in the engine production, and accordingly, they are warranted by Ingersoll Rand.

Genuine Ingersoll Rand parts are supplied by your Ingersoll Rand branch or distributor.

Please ensure that only genuine Ingersoll Rand parts, lubricants and fluids are used for service and/or repair.

EPA Certified Engine Data and Specifications - 3IRH8N

Model: 3IRH8N		
Engine model name		3IRH8N
Engine type		Vertical inline water cooled diesel engine
Combustion type		Direct injection
No. of cylinders - bore X stroke mm		3 - 88 X 90
Engine displacement L		1.642
Compression ratio		19.1:1
Firing order		1 - 3 - 2
Exhaust emission control system		Fuel injection nozzles, fuel injector pump
Governor		Mechanical type
Injection nozzles		Hole type
Specified fuel		Diesel fuel (ISO 8217 DMA, BS2869 A1/A2)
Starter	(V-kW)	12 - 1.2
Alternator	(V-A)	12 - 40
Specified engine oil (API grade) (SAE grade)		(CD, CF) (10W-30 or 15W-40)
Coolant volume (Engine only) L		2.0
Engine dry weight kg		155
Engine dimensions	Overall length mm	564
	Overall width mm	486
	Overall height mm	622
Valve clearance (cold) mm		0.2 ± 0.05
Nozzle injection pressure MPa		21.6
Injection timing B.T.D.C. at 2.5 mm cam lift		18° ±1

Engine Identification

Serial No. Location

The engine serial number is stamped on engine name plate on top of rocker cover. See illustration on *Page - 119*.

Confirmation of Engine Number

It is advisable to quote the engine serial number together with the machine serial number, as it is required when you contact the Ingersoll Rand branch or distributor for repair, service or parts ordering.



Conduct confirmation of engine serial number with the engine stopped. To avoid being injured, do not check it, while the engine is still hot.

Ingersoll Rand Engine After Service

Please feel free to contact your Ingersoll Rand dealer for periodical inspection and maintenance.

Ingersoll Rand Genuine Parts

Genuine Ingersoll Rand parts are identical with those used in the engine production, and accordingly, they are warranted by Ingersoll Rand.

Genuine Ingersoll Rand parts are supplied by your Ingersoll Rand branch or distributor.

Please ensure that only genuine Ingersoll Rand parts, lubricants and fluids are used for service and/or repair.

EPA Certified Engine Data and Specifications - 4IRH8N

Model: 4IRH8N		
Engine model name	4IRH8N	
Engine type	Vertical inline water cooled diesel engine	
Combustion type	Direct injection	
No. of cylinders - bore X stroke mm	88 X 90	
Engine displacement L	2.19	
Compression ratio	19:1	
Firing order	1 - 3 - 4 - 2	
Exhaust emission control system	Fuel injection nozzles, fuel injector pump	
Governor	Mechanical type	
Injection nozzles	Hole type	
Specified fuel	Diesel fuel (ISO 8217 DMA, BS2869 A1/A2)	
Starter (V-kW)	12 - 1.4	
Alternator (V-A)	12 - 40	
Specified engine oil (API grade) (SAE grade)	(CD, CF) (10W-30 or 15W-40)	
Coolant volume (Engine only) L	2.7	
Engine dry weight kg	170	
Engine dimensions	Overall length mm	658
	Overall width mm	498.5
	Overall height mm	618
Valve clearance (cold) mm	0.2 ± 0.05	
Nozzle injection pressure MPa	21.6	
Injection timing B.T.D.C. at 2.5 mm cam lift	19.5° ±1	

Engine Identification

Serial No. Location

The engine serial number is stamped on engine name plate on top of rocker cover. See illustration on *Page - 119*.

Confirmation of Engine Number

It is advisable to quote the engine serial number together with the machine serial number, as it is required when you contact the Ingersoll Rand branch or distributor for repair, service or parts ordering.



Conduct confirmation of engine serial number with the engine stopped. To avoid being injured, do not check it, while the engine is still hot.

Ingersoll Rand Engine After Service

Please feel free to contact your Ingersoll Rand dealer for periodical inspection and maintenance.

Ingersoll Rand Genuine Parts

Genuine Ingersoll Rand parts are identical with those used in the engine production, and accordingly, they are warranted by Ingersoll Rand.

Genuine Ingersoll Rand parts are supplied by your Ingersoll Rand branch or distributor.

Please ensure that only genuine Ingersoll Rand parts, lubricants and fluids are used for service and/or repair.

EPA Certified Engine Data and Specifications - 4IR18N

Model: 4IR18N		
Engine model name	4IR18N	
Engine type	Vertical inline water cooled diesel engine	
Combustion type	Direct injection	
No. of cylinders - bore X stroke mm	4 - 98 X 110	
Engine displacement L	3.319	
Compression ratio	18.1:1	
Firing order	1 - 3 - 4 - 2	
Exhaust emission control system	Fuel injection nozzles, fuel injector pump	
Governor	Mechanical type	
Injection nozzles	Hole type	
Specified fuel	Diesel fuel (ISO 8217 DMA, BS2869 A1/A2)	
Starter (V-kW)	12 - 2.3	
Alternator (V-A)	12 - 40	
Specified engine oil (API grade) (SAE grade)	(CD, CF) (10W-30 or 15W-40)	
Coolant volume (Engine only) L	4.2	
Engine dry weight kg	220	
Engine dimensions	Overall length mm	719
	Overall width mm	508
	Overall height mm	717
Valve clearance (cold) mm	0.2 ± 0.05	
Nozzle injection pressure MPa	21.6	
Injection timing B.T.D.C. at 2.5 mm cam lift	15.3° ±1	

Engine Identification

Serial No. Location

The engine serial number is stamped on engine name plate on top of rocker cover. See illustration on *Page - 119*.

Confirmation of Engine Number

It is advisable to quote the engine serial number together with the machine serial number, as it is required when you contact the Ingersoll Rand branch or distributor for repair, service or parts ordering.



Conduct confirmation of engine serial number with the engine stopped. To avoid being injured, do not check it, while the engine is still hot.

Ingersoll Rand Engine After Service

Please feel free to contact your Ingersoll Rand dealer for periodical inspection and maintenance.

Ingersoll Rand Genuine Parts

Genuine Ingersoll Rand parts are identical with those used in the engine production, and accordingly, they are warranted by Ingersoll Rand.

Genuine Ingersoll Rand parts are supplied by your Ingersoll Rand branch or distributor.

Please ensure that only genuine Ingersoll Rand parts, lubricants and fluids are used for service and/or repair.

Emission Control Label

Engine Label (for EPA)

Emission control label is attached on the “top of rocker arm cover”.

The location of emission control label attached on the engine may vary depending on the engine specification.

The following is the sample of a label required for engine emission control information, along with location.

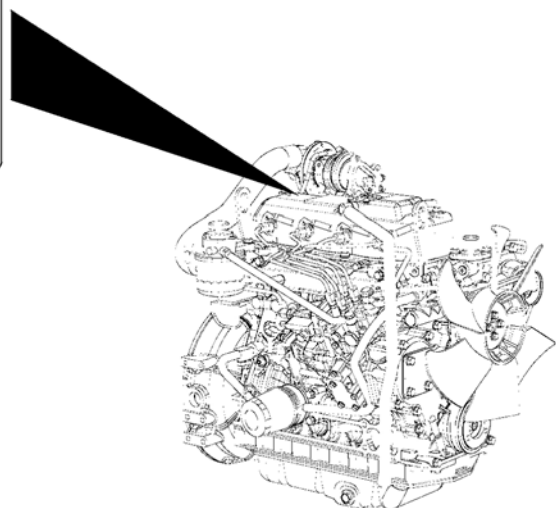
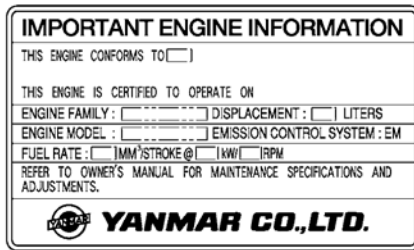

* Engine family name as assigned by EPA and ARB identifying engine family group 3YDXL1.33M3N and this identifies

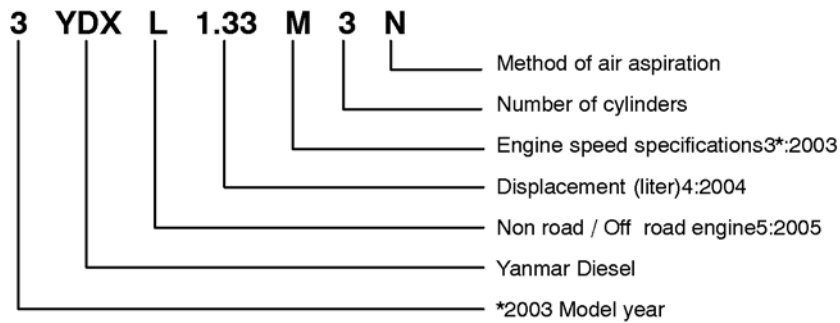

Engine Label (for 4IRL5N)

EC EMISSION CONTROL LABEL: ENGINE LABEL

Emission control label is attached on the “top of the rocker arm cover”.

The following is the detail of a label required for engine emission control information, along with location.

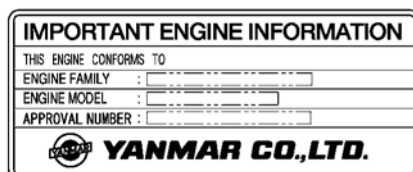

(97/68/EC Directive label)

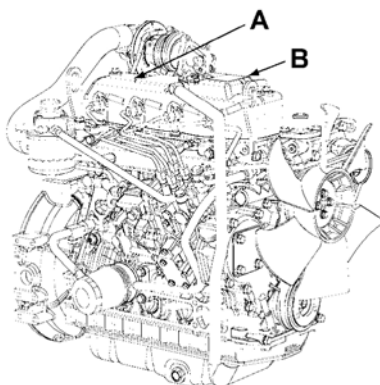

- A. Emission control information label (4IRH8N, 4IRI8N)
- B. Emission control information label (On rocker arm cover exhaust side)
(3IRH2N, 3IRH8N)

Fuel, Lubricants and Coolant

Fuel

Fuel Selection

The following properties are required of the diesel fuel:

- Must be free from minute dust particles.
- Must have adequate viscosity.
- Must have high cetane value.
- Must have high cetane value (45 or greater).
- Must have high fluidity at low temperature.
- Must have low sulphur content.
- Must have little residual carbon.

It is strongly advisable to use ASTM D975 No. 2D (the general automotive diesel engine purpose fuel oil) or equivalent which fully meets the above requirements.

Applicable Standard	Recommendation
JIS (Japanese Industrial Standard)	K2204 - 2
DIN (DEUTSCHE INDUSTRIE NORMEN)	DIN 51601
SAE (Society of Automotive Engineers) Based on SAE-J-313C	No. 2-D
BS (BRITISH STANDARD) Based on BS/2869-1970	Class A-1 or A-2
ISO 8217	DMA

Fuel Requirements

NOTICE

The fuel injection pump, injector or other parts of the fuel system and engine can be damaged if you use any fuel or fuel additive other than those specifically recommended by Ingersoll Rand.

NOTE: If any fuel other than the one specified is used, engine operation will be impaired. Engine failure or malfunction resulting from use of such improper fuel will not be warranted by Ingersoll Rand.

To help avoid fuel system or engine damage, please read the following:

Do not use diesel fuel which has been contaminated with engine oil. Besides causing engine damage, such fuel can also affect emission control. Before using any diesel fuel, check with the fuel supplier to see if the fuel has been mixed with engine oil.

Your engine is designed to use either Number 1-D or Number 2-D diesel fuel. However, for better fuel economy, use Number 2-D diesel fuel whenever possible. At temperatures less than -7°C , (20°F), Number 2-D fuel may pose operating problems (see “Cold Weather Operation” which follows). At colder temperatures, use Number 1-D fuel (if available) or use a “winterized” Number 2-D (a blend of Number 1-D and Number 2-D). This blended fuel is usually called Number 2-D also, but can be used in colder temperatures than Number 2-D fuel which has not been “winterized”.

Check with the fuel supplier to be sure you get the properly blended fuel.

NOTICE

Do not use home heating oil or gasoline in your diesel engine; either may cause engine damage.

Handling of the Fuel

Any fuel containing dust particles or water might cause engine failure.

Therefore, the following must be observed:

- Take care to protect the fuel from ingress of dust particles or water when filling the fuel tank.
- If refueling is done from an oil drum directly, ensure that it has been kept stationary to allow any dust, sediment or water to settle at the bottom. Do not draw fuel direct from the bottom of the drum to prevent pickup of any settled foreign material.
- Always fully fill the fuel tank. Drain the sedimented particles in the fuel tank frequently.

Water in Fuel

During refueling, it is possible for water (and other contaminants) to be pumped into your fuel tank along with the diesel fuel. This can happen if a fuel provider does not regularly inspect and clean its fuel tanks, or receives contaminated fuel from its supplier(s). To protect your engine from contaminated fuel, there is a fuel filter system on the engine which allows you to drain excess water.

 **CAUTION**

The water-diesel fuel mixture is flammable, and could be hot. To avoid personal injury and/or property damage, do not touch the fuel coming from the drain valve, and do not expose the fuel to open flames or sparks.

Be sure you do not overfill the fuel tank. Heat (such as from the engine) can cause the fuel to expand. If the tank is too full, fuel could be forced out. This could lead to a fire and the risk of personal injury and/or equipment damage.

Biocides

In warm or humid weather, fungus and/or bacteria may form in diesel fuel if there is water in the fuel.

 **NOTICE**

Fungus or bacteria can cause fuel system damage by plugging the fuel lines, fuel filters or injector. They can also cause fuel system corrosion.

If fungus or bacteria has caused fuel system problems, you should have your authorized dealer correct these problems. Then, use a diesel fuel biocide to sterilize the fuel system (follow the biocide manufacturer's instructions). Biocides are available from your dealer, service stations, parts stores and other automotive places. See your authorized dealer for advice on using biocides in your area and for recommendations on which biocides you should use.

Smoke Suppressants

The use of a smoke suppressant additive is not allowed because of the greater possibility of stuck rings and valve failure, resulting from excessive ash deposits.

Lubricant

The quality of engine oil can affect engine performance, start ability and engine life.

Use of unsuitable engine oil will result in piston ring, piston and cylinder seizure and accelerate surface wear causing increased oil consumption, lowered output and, finally engine failure. To avoid this, use the specified engine oil.

1. Engine Oil Selection: **Pro Tec™**
2. Oil Viscosity

Engine oil viscosity affects engine start ability, performance, oil consumption, wear and the potential for seizure, etc. Always ensure that lubricants with the correct viscosity for the operating temperature are used. Refer to *Fig 12*.

NOTE: Using a mixture of different brands or quality of oils will adversely affect the original oil quality; therefore, never mix different brand or different type oils.

Do not use API, CA, CB grade and reconstituted engine oil.

Engine damage due to improper maintenance, or using oil of the improper quality and/or viscosity, is not covered by the warranty.

Fig 12:

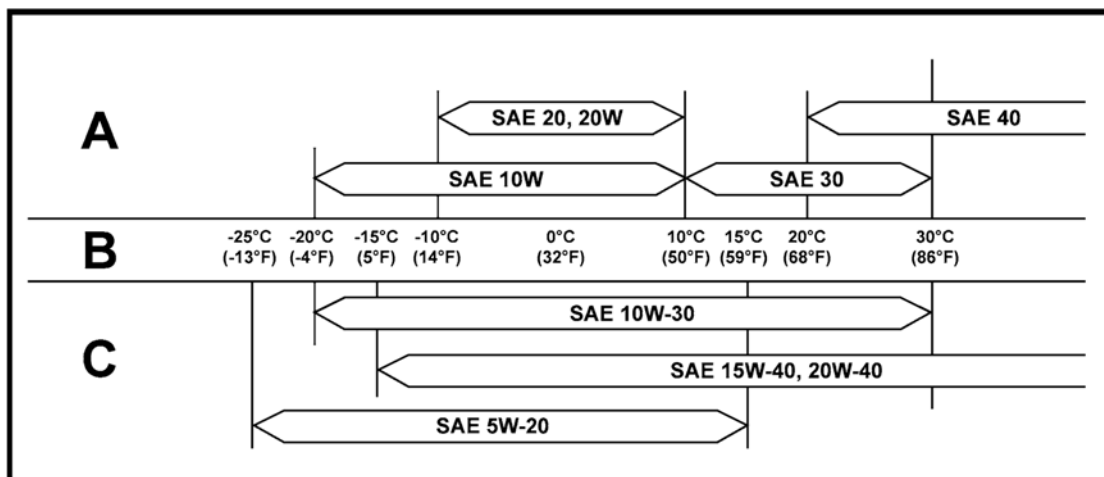

- A. Single - grade
- B. Ambient Temperature
- C. Multi - grade

Coolant

All Ingersoll- Rand portable compressor engines are factory filled with a 50/50 Ethylene glycol base antifreeze/water mix. which provides protection to -33° C (-27° F).

NOTICE

Be sure to add Long Life Coolant Antifreeze (LLC) to soft water. In cold season, the LLC is especially important. Without LLC, cooling performance will decrease due to scale and rust in the cooling water line. Without LLC, cooling water will freeze and expand to break the cooling line.

Be sure to use the mixing ratios specified by the LLC manufacturer for your temperature range.

Do not mix different types (brand) of LLC, chemical reactions may make the LLC useless and engine trouble could result.

Replace the cooling water every once a year.

⚠ CAUTION

When handling Long Life Coolant Antifreeze, wear protective rubber gloves not to contact with it. If contact with the eyes or skin should occur, wash with clean water.

Engine Operation

Engine Exhaust Gas Caution (Carbon Monoxide)

⚠ CAUTION

Do not breathe exhaust gas because it contains carbon monoxide, which by itself has no color or odor. Carbon monoxide is a dangerous gas. It can cause unconsciousness and can be lethal.

Do not run the engine in confined areas (such as garages or next to a building). Keep the exhaust tailpipe area clear of snow and other material to help reduce the buildup of exhaust gases under the equipment. This is particularly important when parked in blizzard conditions.

Check Before Operation

⚠ CAUTION

For safety reasons, conduct the inspection with the engine stopped.

Engine Oil Level

Place the engine or the machine on a level surface.

Remove the dipstick, wipe it with a cloth. Insert it fully and take it out gently again.

Check the oil level against the marks on the dipstick. The oil level must be between the upper level mark and the lower level mark as illustrated.

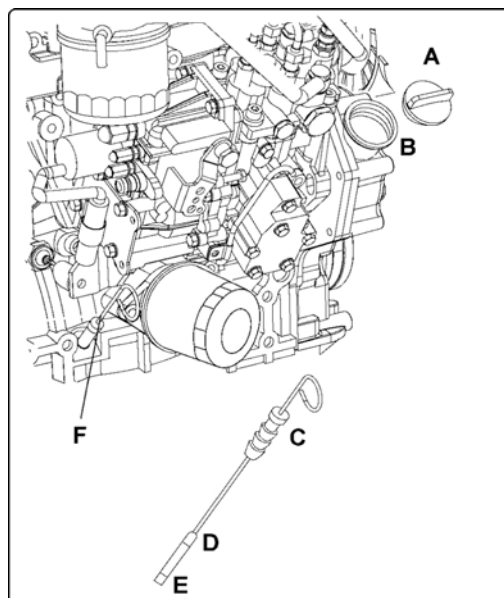

- A. Filler cap
- B. Filler port (engine oil)
- C. Dipstick
- D. Upper limit
- E. Lower limit
- F. Dipstick

Remove filler cap (yellow coloured) on the rocker arm cover side of engine.

Fill with engine oil up to the upper limit on the dipstick.

Manually tighten the filler cap. Do not use a tool such as pliers to tighten it.

Table of oil pan capacities.

Engine oil pan capacity (oil pan) (L)	
3IRH2N	5.5
3IRH8N	6.7
4IRH8N	7.4
4IRI8N	10.2

A certain period of time is required before the engine oil completely flows down from the oil filler to the crankcase. Wait at least ten minutes before checking the oil level.

NOTE: Take care to avoid engine oil being splashed on the fan drive belt because it causes belt slippage or slackness.



When adding oil, take care not to spill it. If you spill oil on the engine or equipment, wipe it properly, to prevent the risk of fire and personal injury and/or equipment damage.

Fan Belt Check

Check the fan belt for tension and abnormalities.

When the belt is depressed 7 - 10 mm with the thumb (about 100 N [10 kg] pressure) midway between the fan pulley and alternator pulley, the belt tension is correct.

If the belt tension is too high, it will result in alternator failure.

A loose belt will cause belt slippage which may result in a damaged belt, abnormal noise, poor battery charging and engine overheating.

Fig 16:

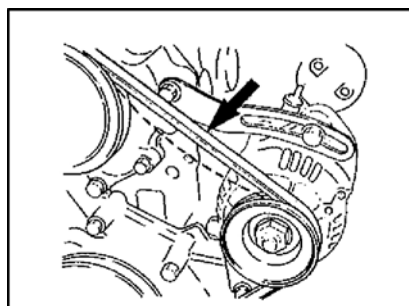

Coolant Level Check

The coolant level must be between “MAX COLD” and “MIN” marks on the reserve tank depending on the temperature of the engine. Check and ensure that the level is correct.

CAUTION

When removing the radiator filler cap, while the engine is still hot, cover the cap with cloth, then turn it slowly to gradually release the internal steam pressure. This will prevent anyone from being scalded by hot steam spurting out from the filler neck.

Add coolant mixed to the correct ratio: 50/50 ethylene glycol/water.

Radiator Cap Condition

After the replenishment of the coolant, install the radiator filler cap. Make sure the cap is securely installed.

Battery Cable Connection

Check the battery cable connections for looseness or corrosion. A loosened cable connection will result in hard engine starting or insufficient battery charge. The battery cables must be tightened securely. Never reverse “+” and “-” terminals when reconnecting cables after disconnection. Even a short period of reverse connection will damage the electrical parts.

Fig 17:

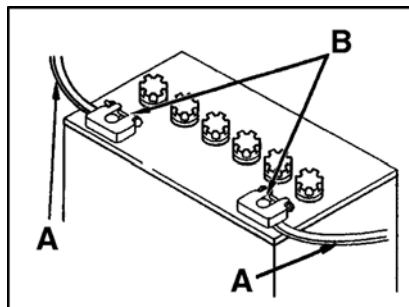

A. Battery cable

B. Connections

Battery Electrolyte Level

The amount of electrolyte in the batteries will be reduced after repeated discharge and recharge. Check the electrolyte level in the batteries, replenish with a commercially available electrolyte such as distilled water, if necessary. The battery electrolyte level checking procedure will vary with battery type.

NOTICE

Do not replenish with dilute sulphuric acid in the daily service.

CAUTION

When inspecting the batteries, be sure to stop the engine first.

As dilute sulphuric acid is used as electrolyte, be careful not to contaminate your eyes, hands, clothes, and metals with the electrolyte. If it gets in your eye, wash with a large amount of water at once, then seek medical advice.

As highly flammable hydrogen gas is released from the batteries, do not create a spark or allow any naked flame near the batteries.

When handling such metallic articles as tools near the batteries, be sure not to contact the “+” terminal because the compressor body is “-” and a dangerous short circuit might result.

When disconnecting the terminals, start with “-” terminal. When connecting them, connect the “-” terminal last.

Fuel Level

Check the remaining fuel oil level in the fuel tank and re-fuel if necessary.

Checks and Operation after Start-Up

Check After the Engine Start-Up

Check the following items in the engine warming-up operation.

Engine noise and exhaust smoke color

Listen to the engine and, if any abnormal noise is heard, check to determine the cause.

Check the fuel combustion condition by observing the exhaust smoke color. The exhaust smoke color after engine warm-up and at no-load condition should be colorless or light blue.

Black or white smoke indicates incorrect combustion.

NOTE: After start-up from cold the engine might be noisier and the exhaust smoke color darker than when it has warmed up. However this condition will disappear after warm up.

Leakage in the Systems

Check the following items:

Lubrication oil leakage - Check the engine for oil leaks, paying particular attention to oil filter and oil pipe joints.

Fuel leakage - Check the fuel injection pump, fuel lines and fuel filter for leakage.

Coolant leakage - Check the radiator and water pump hose connections and the water drain cock on the cylinder block for leakage.

Exhaust smoke or gas leakage.

Checking Coolant Level

The coolant level could drop because any mixed air is expelled in about 5 minutes after the engine started.

Stop the engine, remove radiator cap, and add coolant.

CAUTION

Hot steam can rush out and you could get burnt if the radiator cap is removed when the engine is hot. Cover the radiator cap with a thick cloth and loosen the cap slowly to reduce the pressure, then remove the cap.

Operation and Care of a New Engine

Your Ingersoll Rand engine is carefully tested and adjusted in the factory, however, further run-in is necessary. Avoid any harsh engine operation within the initial 100 operating hours.

Do not operate the unit at full load until the engine is warmed-up.

Do not allow the engine to run unloaded for extended periods so as to minimize the risk of cylinder bore glazing.

During operation, pay attention to the following points if the engine shows any sign of abnormalities.

1. **Engine Oil Pressure** - The engine oil pressure is monitored by a switch that will stop the engine if the pressure falls below a pre-set value.
2. **Coolant Temperature** - The engine performance will be adversely affected if engine coolant temperature is too hot or too cold. The normal coolant temperature is 75 to 85° C (167 to 185° F).

Overheating



If you see or hear escaping steam or have other reason to suspect there is a serious overheat condition, stop the engine immediately.

If the Engine Coolant Temperature gauge (where fitted) shows an overheat condition, or you have reason to suspect the engine may be overheating, take the following step:

- Close the service valve to reduce the load.
- Let the engine run at normal idle speed for two or three minutes. If the engine coolant temperature does not start to drop, turn OFF the engine and proceed as follows:



To help avoid being burned:

- **Do not open the canopy or door if you see or hear steam or engine coolant escaping. Wait until no steam or engine coolant can be seen or heard before opening the engine canopy or door.**
- **Do not remove the radiator filler cap if the engine coolant in the reserve tank is boiling. Also do not remove the radiator filler cap while the engine and radiator are still hot. Scalding fluid and steam can be blown out under pressure if either cap is taken off too soon.**

If no steam or engine coolant can be seen or heard, open the canopy or door. If the engine coolant is boiling, wait until it stops before proceeding. The engine coolant level should be between the “MAX COLD” and “MIN” marks on the reserve tank.

Make sure the fan belt is not broken, or off the pulley, and that the fan turns when the engine is started. If the engine coolant level in the reserve tank is low, look for leaks at the radiator hoses and connections, radiator, and water pump. If you find major leaks, do not run the engine until these problems have been corrected. If you do not find a leak or other problem, WAIT UNTIL THE ENGINE HAS COOLED DOWN then carefully add engine coolant to the reserve tank.

(Engine coolant is a mixture of ethylene glycol antifreeze and water. See “Engine Care in cold season” for the proper antifreeze and mixture).

 **CAUTION**

To avoid being burned, do not spill antifreeze or engine coolant on the exhaust system or hot engine parts. Under some conditions the ethylene glycol in engine coolant is combustible.

If the engine coolant level in the reserve tank is at the correct level but there is still an indication of an overheat condition and no cause was found, please consult your local Ingersoll Rand branch or dealer.

Overcooling

Operating the engine at low coolant temperature will not only increase the oil and fuel consumption but also will lead to premature parts wear which may result in engine failure. Ensure that the engine reaches normal operating temperature 75 to 85° C (167 to 185° F) within ten minutes of starting.

3. **Hourmeter** - This meter indicates the machine operation hours. Make sure that the meter is always working during engine operation. Periodical machine maintenance is scheduled on the operation hours indicated on the hourmeter.
4. **Liquid and Exhaust Smoke Leakage** - Make regular checks for lubricant, fuel, coolant and exhaust smoke leakage.
5. **Abnormal Engine Noise** - In the event of any abnormal engine noise, please consult your local Ingersoll Rand branch or dealer.
6. **State of the Exhaust Smoke** - Check for any abnormal exhaust smoke color.

Engine Stopping

1. Close service valves.
2. Before stopping the engine, cool down the engine by operating it at reduced load about three minutes. In this period, check the engine noise for abnormalities.

Long Term Storage

If the equipment is to be out of operation for an extended period, it should be started at least once per week and run on load for about 15 minutes after it has reached normal operating temperature.

If this is not possible,

- Do not drain the cooling water.
- Clean dust or oil from the engine extension.
- Either fill completely or drain the fuel tank.
- Grease accelerator joints and electrical connections.
- Disconnect the negative battery terminal.

Engine Maintenance Schedule

When performing the following items, the daily inspection items should also be carried out.

NOTE: Establish a periodic check plan according to the operating conditions and make sure to conduct checks at specified intervals. Otherwise, malfunctioning may occur to shorten the engine life.

As special knowledge and skill are required for items marked with ●, consult your local Ingersoll Rand branch or distributor.

○: Check

□ : Replace

●: Contact your dealer

System	Check item	Daily	Periodic inspection interval				
			Every 50 hrs	Every 250 hrs	Every 500 hrs	Every 1000 hrs	Every 2000 hrs
Fuel Oil	Fuel tank oil level check and refill	○					
	Draining from fuel tank		○				
	Draining from oil/water separator		○				
	Cleaning oil/water separator				○		
	Fuel filter replacement				□		
Engine Oil	Engine oil level	○					
	Engine oil replacement		□		□		
	Engine oil filter replacement		1 st time		2 nd & after		
Cooling Water	Check & addition cooling	○					
	Radiator fin checking & cleaning			○			
	Cooling fan V-belt checking & adjusting		○ 1 st time	○ 2 nd & after			
	Cooling water replacement					□ or every 1 yr	
	Cooling water path flushing & maintenance						●
Rubber Hoses	Fuel & cooling water pipe replacement						● or every 2 yrs
Operating System	Governor lever & accelerator check & adjust	○		○			
Intake & Exhaust	Air cleaner element cleaning & replacement			○	□		
Electrical Equipment	Battery electrolyte check and recharging		○				
Cylinder Head	Adjust intake/exhaust valve clearance					●	
	Lapping intake/exhaust valve seats						●
Fuel Valve Pump*	Check fuel injection valve pressure & adjust					●	
	Check and adjust fuel injection pump						●

* The specific emissions related parts for the EPA/ARB regulations

EPA allows to apply Maintenance schedule for Emission related parts as follows.

---	Check Fuel Valve Nozzle and clean	Adjust, cleaning and repair of fuel injection Pump and fuel valve nozzle
kW ≤ 130	1500 hours of use and at 1500-hour intervals thereafter	3000 hours of use and at 3000-hour intervals thereafter

Periodical Inspection and Maintenance

Inspection after Initial 50 Hours Operation

Replacing the Engine Oil and Engine Oil Filter (1st time)

When the engine oil is still hot, be careful with a splash of engine oil which may cause burns. Cool the engine to replace engine oil until the engine oil becomes warm. It is most effective to drain the engine oil while the engine is still warm.

In early period of use, the engine oil gets dirty rapidly because of the initial wear of internal parts. Replace the engine oil earlier.

Engine oil filter should also, be replaced when the engine oil is replaced.

Engine oil and engine oil filter replacing procedures are as follows:

- Remove the oil filler cap to drain easily while draining the engine oil.
 1. Prepare a waste oil container collecting waste oil.
 2. Loosen the drain plug using a wrench (customer procured) to drain the engine oil.
 3. Securely tighten the drain plug after draining the engine oil.
 4. Turn the engine oil filter counter-clockwise using a filter wrench (customer procured) to remove it.
 5. Clean the engine oil filter mounting face.
 6. Moisten the new engine oil filter gasket with the engine oil and install the new engine oil filter manually turning it clockwise until it comes into contact with the mounting surface, and tighten it further to 3/4 of a turn with the filter wrench.

Tightening torque: 19.6~23.5 N•m (2.0~2.4 kgf•m)

Applicable engine oil filter Part No.	
All engines	CCN 15897630

7. Fill with the new engine oil until it reaches the specified level as explained in “*Engine Oil Level*”.

NOTE: Do not overfill the oil pan with engine oil. Be sure to keep the specified level between upper and lower limit on the dipstick.

8. Warm up the engine by running for 5 minutes while checking any oil leakage.

9. Stop the engine after warming up and leave it stopping for about 10 minute to recheck the engine oil level with dipstick and replenish the engine oil. If any oil is spilled, wipe it away with a clean cloth.

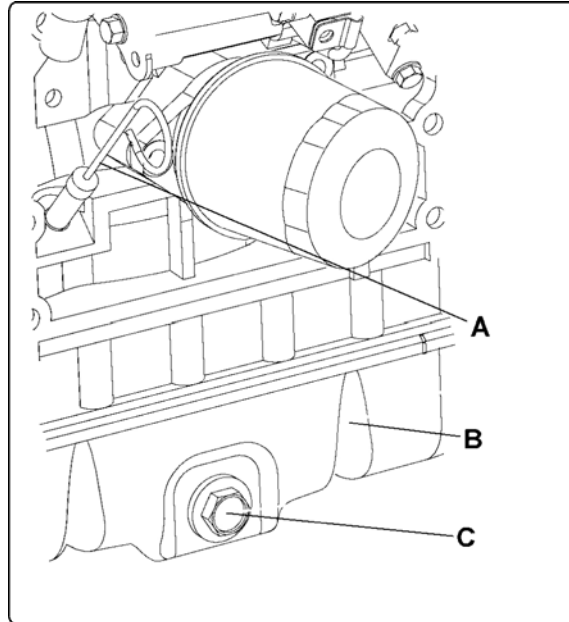

The location depends on the engine installed on the machine unit.

A. Dipstick

B. Oil pan

C. Drain plug

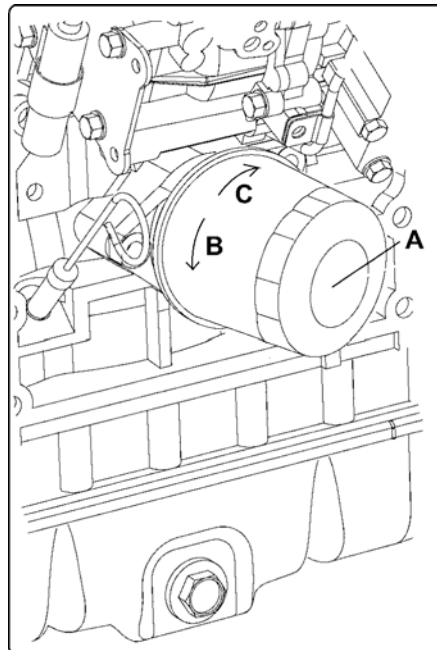

A. Engine oil filter

B. Loosen

C. Tighten

Checking and Adjusting Cooling Fan V-Belt

When there is not enough tension in the V-belt, the V-belt will slip making it impossible for the alternator to generate power and cooling water pump and cooling fan will not work causing the engine to overheat. Check and adjust the V-belt tension (deflection) in the following manner.

1. Press the V-belt down with your thumb [approx. 98N (10kgf)] at the middle of the V-belt span to check the tension (deflection).

Available positions to check and adjust the V-belt tension (deflection) are at the A, B and C showing with the arrow direction as shown illustration right.

You may choose a position whichever you can most easily carry out the check and adjustment on the machine unit.

The specified deflection to be measured at each position should be as follows.

A	B	C
10~14mm	7~10mm	9~13mm

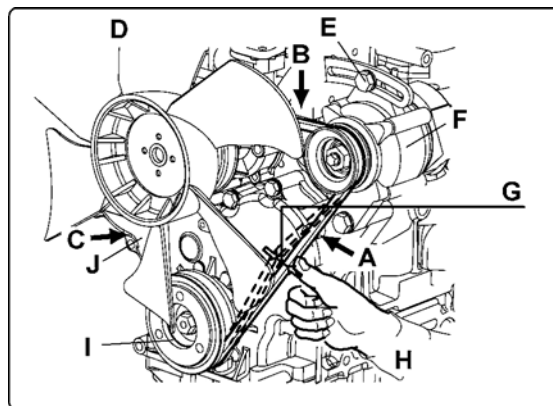

- | | | |
|------------------------|----------------------------|-------------------------------|
| D. Radiator fan | G. Deflection | I. Crankshaft V-pulley |
| E. Set bolt | H. Press with thumb | J. V-belt |
| F. Alternator | | |

2. If necessary, adjust the V-belt tension (deflection). To adjust the V-belt tension, loosen the set bolt and move the alternator to tighten the V-belt.
3. Visually check the V-belt for cracks, oiliness or wear. If any, replace the V-belt with new one.
 - “New V-belt” refers to a V-belt which has been used less than 5 minutes on a running engine.
 - “Used V-belt” refers to a V-belt which has been used on a running engine for 5 minutes or more.

- Install the new V-belt adjusting the deflection to the value in the table below according to the above manner. After adjusting, run the engine for 5 minutes and readjust the deflection to the value in the table above.

A	B	C
8~12mm	5~8mm	7~11mm

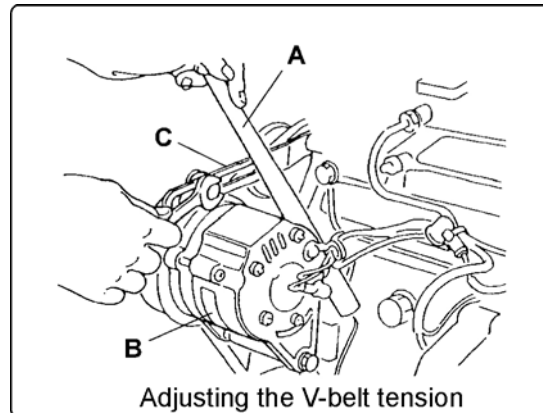

A. Adjust the V-belt tension by prying with a wooden bar **B.** Alternator **C.** Adjusting bracket

Use of Genuine Ingersoll Rand Fan Belt

Always use genuine Ingersoll Rand fan belts as they provide high driving ability and long operating durability. Use of non-Ingersoll Rand fan belts could result in premature belt wear or belt elongation leading to engine overheating or excessive belt noise.

⚠ CAUTION

To help avoid being injured, check and adjust the fan belt tension with engine stopped.

Inspection Every 50 Hours Operation

Draining of the Fuel Tank (NOT 7/26E, 7/31E)

1. Prepare a waste oil container.
2. Remove the drain plug of the fuel tank to drain (water, dust, etc.) from the fuel tank bottom.
3. Drain until fuel with no water and dust flow out. Then tighten the drain plug firmly.

Draining of the Oil/Water Separator

Draining Water from Fuel Filter/Separator

The fuel filter/separator is provided to allow water to be drained from the fuel system. Water is heavier than fuel so any water contained in the system will collect in the bottom of the bowl.

The clear bowl 'D' should be checked on a daily basis and if water is present, it should be drained from the separator.

Place a suitable container under the separator to prevent any spillage inside the machine.

Slacken the drain valve 'E' until water drains from the vent tube.

When all the water has been evacuated, tighten the drain valve 'E' and follow the "Fuel System Air Bleeding" procedure below.

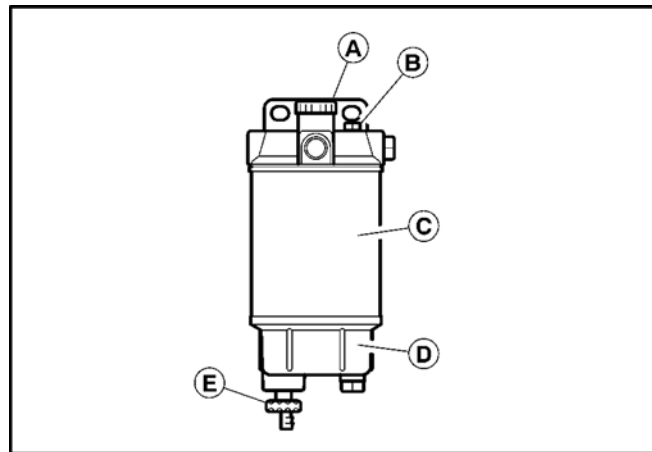

Fuel System Air Bleeding

The entry of air into the fuel system will cause difficult engine starting or engine malfunction.

When carrying out service procedures such as emptying the fuel tank, draining the filter/separator, and changing the fuel filter element be sure to bleed air from the fuel system.

To activate the "automatic air-bleeding system", turn the key switch to the "ON" position and energize the electromagnetic pump to bleed the air.

Air bleeding method:

When the “starter switch” is set to the “ON” position to activate the electromagnetic pump, fuel is forced to the fuel valve of each injection pump and then to the leak-off pipe of each injector nozzle, so that any air in the fuel system bleeds off automatically to the fuel tank.

NOTE: Although the fuel system can bleed air automatically when the key switch 1 is in the “ON” position, air can also be manually bled by use of the primer pump facility in the filter/separator assembly. By unscrewing the plastic primer pump head ‘A’ and stroking it up and down, any air bubbles in the system will be purged back to the fuel tank. When this has been completed, the pump head must be screwed back into the filter/separator assembly.

Start the engine and visually check the fuel system for leaks.

Governor Control Seals

As the governor is precisely adjusted, most of the controls are sealed, please do not break them. Should any adjustment be necessary, contact your local Ingersoll Rand branch or distributor.

NOTE: Ingersoll Rand will not accept any warranty claim on an engine with broken governor seals.

Inspection of Battery

Fire due to Electric Short-Circuit



- Make sure to turn off the battery switch or disconnect the negative cable (-) before inspecting the electrical system. Failure to do so could cause short-circuit and fires.
- Always disconnect the (-) Negative battery cable first before disconnecting the battery cables from battery. An accidental “Short-circuit” may cause damage, fire and or personnel injury.

And remember to connect the (-) Negative battery cable (back onto the battery) LAST.

Proper Ventilation of the Battery Area

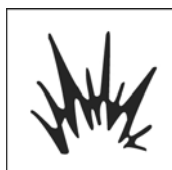

Keep the area around the battery Well ventilated, paying attention to keep away any fire source. During operation or charging, hydrogen gas is generated from the battery and can be easily ignited.

Do not come in Contact with Battery Electrolyte

Pay sufficient attention to avoid your eyes or skin from being in contact with the fluid. The battery electrolyte is dilute sulphuric acid and causes burns. Wash it off immediately with a large amount of fresh water if you get any on you.

- Clean the battery terminals.
- Check the level of fluid in the battery.

When the amount of fluid nears the lower limit, fill with battery fluid (available in the market) to the upper limit. If operation continues with insufficient battery fluid, the battery life is shortened, and the battery may overheat and explode.

- Battery fluid tends to evaporate more quickly in the summer, and the fluid level should be checked earlier than the specified times.
- If the engine cranking speed is so slow that the engine does not start up, recharge the battery.
- If the engine still will not start after charging, replace the battery.
- Remove the battery from the battery mounting of the machine unit after daily use if letting the machine unit leave in the place that the ambient temperature could drop at -15°C or less. And store the battery in a warm place until the next use of the unit to start the engine easily at low ambient temperature.

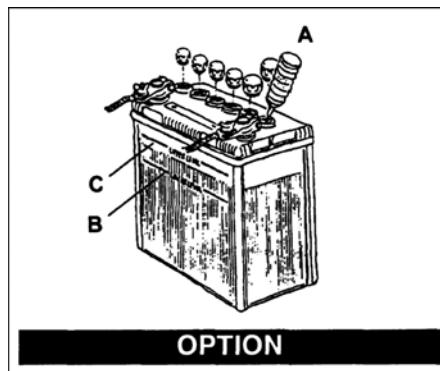

Follow the instructions and precautions in the manual from the battery maker.

- A. Battery fluid
- B. Lower limit
- C. Upper limit

Inspection Every 250 Hours Operation

Replacing the Engine Oil and Engine Oil Filter (2nd time and after)

Replace the engine oil every 250 hours operation from 2nd time and on. Replace the engine oil filter at the same time. Refer to “*Inspection Every 50 Hours Operation*”.

Checking and Cleaning Radiator Fins.

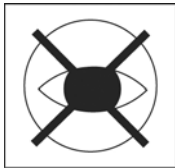

Beware of Dirt from Air Blowing

Wear-protective equipment such as goggles to protect your eyes when blowing compressed air. Dust or flying debris can hurt eyes.

Dirt and dust adhering on the radiator fins reduce the cooling performance, causing overheating. Make it a rule to check the radiator fins daily and clean as needed.

- Blow off dirt and dust from fins and periphery with compressed air [0.19MPa (2kgf/cm²) or less] not to damage the fins with compressed air.
- If contaminated heavily, apply detergent, thoroughly clean and rinse with tap water shower.

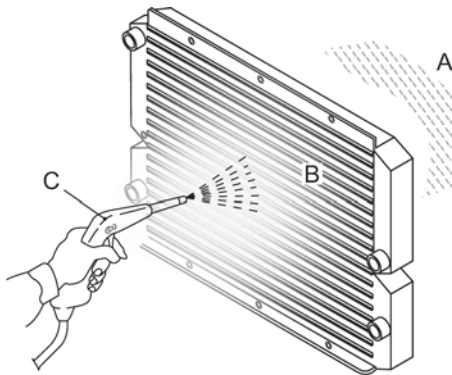

A. Dust, dirt.

B. Radiator fins

C. Air blow

NOTE: Never use high pressure water or air from close by fins or never attempt to clean using a wire brush. Radiator fins can be damaged.

Checking the Governor Lever and Accelerating Device.

The governor lever and accelerating devices (accelerating lever, pedal, etc.) of the machine unit are connected by a fixed linkage to a pneumatic actuator. If the linkage becomes loose, the deviation in the position may result and make operation unsafe. Check the linkage connections for excess play. For adjustment of linkage see compressor operation section.

Governor Control Seals

As the governor is precisely adjusted, most of the controls are sealed, please do not break them. Should any adjustment be necessary, contact your local Ingersoll Rand branch or distributor.

NOTE: Ingersoll Rand will not accept any warranty claim on an engine with broken governor seals.

Replacing Fuel Filter

Replace the fuel filter at specified intervals before it is clogged with dust to adversely affect the fuel flow. Also, replace the fuel filter after the engine has fully been cooled.

1. Remove the fuel filter using a filter wrench (customer procured). When removing the fuel filter, hold the bottom of the fuel filter with a piece of rag to prevent the fuel oil from dropping. If you spill fuel, wipe such spillage carefully.
2. Clean the filter mounting surface and slightly apply fuel oil to the gasket of the new fuel filter.
3. Install the: new fuel filter manually turning until it comes into contact with the mounting surface, and tighten it further to ½ at a turn, using a filter wrench. Tightening torque: 11.8~15.6 N•m (1.2~1.6 kgf•m)

Applicable fuel filter Part No.	
All engines	CPN 15892747

4. Bleed the fuel system. Refer to *“Inspection Every 50 Hours Operation”*.

NOTE: Be sure to use genuine Yanmar part (super fine mesh filter). Otherwise, it results in engine damage, uneven engine performance and shorter engine life.

Changing Oil/Water Separator Element

NOTE: The cartridge and bowl contain fuel. Take care not to spill it during disassembly and reassembly.

The fuel filter/separator also provides primary filtration and the element ‘C’ should be changed every 500 operating hours or 6 months, whichever comes first

Change procedure:

Unscrew the element ‘C’ from the head taking care not to spill fuel inside the machine. Drain any fuel within into a suitable container, then unscrew the clear bowl ‘D’ from the element.

Discard the old element into a suitable container.

Remove the old 'O' ring from the bowl 'D' and install the new one supplied with the element. Apply a light coat of clean engine oil to the 'O' ring and screw the bowl 'D' onto the new element 'C'.

Using a clean cloth, wipe the sealing face of the filter/separator head to ensure correct seating of the sealing ring.

Fill the element/bowl assembly with clean fuel oil then apply a light coat of clean engine oil to the new element seal ring.

Screw the new element onto the head firmly by hand.

Follow the *"Fuel System Air Bleeding"* procedure. See *"Inspection Every 50 Hours Operation"*.

Air Intake System

Air Cleaner

Engine performance and life vary with the air intake conditions.

A dirty air cleaner element reduces the amount of intake air, causing reduced engine output and possible engine damage.

Also, a damaged element leads to abrasion of cylinders and valves, resulting in increased oil consumption, reduced output and shortened engine life.

Inspect the Condition of the Element:

Fig 32 :

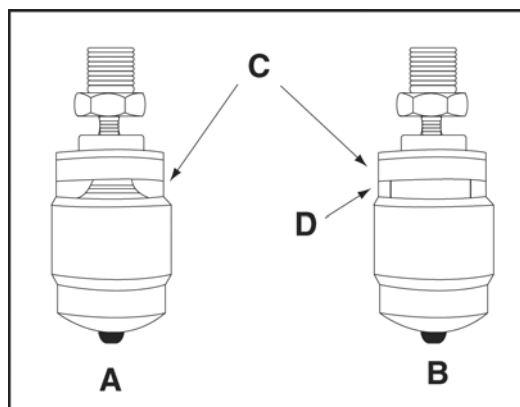

- A. Normal
- B. Clogged
- C. Indicator
- D. Red Signal

Air Cleaner with Dust Indicator

This indicator is attached to the air cleaner. When the air cleaner element is clogged, air intake resistance becomes greater and the dust indicator signal turns to red indicating the element needs to be changed.

When the signal turns to red, replace the element. Then press the dust indicator button to reset the indication.

Checking and Adjusting Cooling Fan V-Belt (2nd time and after):

Check and adjust the cooling fan V-belt tension every 250 hours operation from 2nd time and on.

See *“Inspection after Initial 50 Hours Operation”*.

Inspection Every 500 Hours Operation

Replacing the Air Cleaner Element

Replace the air cleaner element periodically even if it is not damaged or dirty. When replacing the element, clean the inside air cleaner case at the time. If having the air cleaner with double elements, do not remove the inner element. If the engine output is still not recover (or the dust indicator still actuates if having the air cleaner with a dust indicator) even though the outer element has replaced with new one, replace the inner element with new one.

Inspection Every 1000 Hours Operation

Replacing Cooling Water

Cooling water contaminated with rust or water scale-reduces the cooling effect. Even when antifreeze agent (LLC) is mixed, the cooling water gets contaminated due to deteriorated ingredients. Replace the cooling water at least once a year.

1. Remove the header tank cap.
2. Remove the bottom radiator hose of the radiator and drain the cooling water.
3. After draining the cooling water, reconnect the hose.
4. Fill radiator and engine with cooling water via the header tank.

Beware of Scalding by Hot Water

Wait until the temperature goes down before draining the Cooling water. Otherwise, hot water may splash to cause scalding.

Checking and Adjusting the Fuel Injection Valve

As the adjustment requires specialized knowledge and skill, consult your Ingersoll Rand dealer. This adjustment is needed to obtain the optimum injection pattern for full engine performance.

Adjusting Intake/Exhaust Valve Clearance

As this adjustment requires specialized knowledge and skill, consult your Ingersoll Rand dealer. The adjustment is necessary to maintain the correct timing for the opening and closing of valves. Neglecting the adjustment will cause the engine to run noisily and result in poor engine performance and other damage.

Inspection Every 2000 Hours Operation

Flushing the Cooling System & Checking the Cooling System Parts

As this maintenance requires specialized knowledge and skill, consult your Ingersoll Rand dealer. Rust and water scale will accumulate in the cooling system through many hours of operation. This lowers the engine cooling effect.

And for the engine oil cooler (4TNV98T), they quickly deteriorate the engine oil.

Cooling system parts: radiator, cooling water pump, thermostat, cylinder block, cylinder head, oil cooler (4TNV98T).

Checking and Replacing Fuel Hoses and Cooling Water Hoses

As this maintenance requires specialized knowledge and skill, consult your Ingersoll Rand dealer. Regularly check the rubber hoses of the fuel system and cooling water system. If cracked or degraded, replace them with new one. Replace the rubber hoses at least every 2 years.

Lapping the Intake and Exhaust Valves

As this maintenance requires specialized knowledge and skill, consult your Ingersoll Rand dealer. The adjustment is necessary to maintain proper contact of the valves and seats.

Checking and Adjusting the Fuel Injection Timing

As this maintenance requires specialized knowledge and skill, consult your Ingersoll Rand dealer.

Checking and Adjusting the EPA Emission Related Parts.

The inspection and servicing require specialized knowledge and techniques. Consult your Ingersoll Rand dealer or distributor.

EPA allows to apply maintenance schedule for emission related parts as follow.

---	Check Fuel Valve Nozzle and clean	Adjust, cleaning and repair of fuel injection Pump and fuel valve nozzle
kW ≤ 130	1500 hours of use and at 1500-hour intervals thereafter	3000 hours of use and at 3000-hour intervals thereafter

Engine Maintenance Schedule

NOTE: * This is a recommended maintenance. The failure to perform this maintenance item will not nullify the emission warranty or limit recall liability prior to the completion engine useful life. Ingersoll Rand, however, urges that recommended maintenance service is performed at the indicated intervals.

Explanation of Maintenance Schedule

The following is a brief explanation of the services listed in the preceding Engine Maintenance schedule.

- | | |
|--|---|
| 1. Oil level | Check that the oil level is between the max. and the min. level marks.
Add oil to the max. level mark if it is below the min. level.
If it is above the max. level mark, drain oil until the max. level is reached. |
| 2. Engine oil replacement | Change at 500 hours or 6 months, whichever comes first. |
| 3. Oil filter element replacement | Change at 500 hours or 6 months, whichever comes first. |
| 4. Fuel leakage | Replace any damaged or malfunctioning parts which could cause leakage. |
| 5. Draining water in fuel filter/ separator | Drain off water in the fuel filter/separator bowl. |
| 6. Fuel filter element replacement | Replace both primary (filter/separator) and secondary elements at 500 hours or 6 months whichever come first. |
| 7. Injection nozzle check | Check injection opening pressure and spray condition. (This is a recommended maintenance item *). Consult your local Ingersoll Rand branch or distributor. |
| 8. Coolant level | Check coolant level and add coolant if necessary. |
| 9. Coolant leakage check | Replace any damaged or malfunctioning parts which could cause leakage. |
| 10. Radiator filler cap fitting condition | The radiator cap must be installed tightly and sealing correctly. |
| 11. Fan belt tension check | Check and adjust fan belt deflection. Look for cracks, fraying and wear. Replace if necessary. |
| 12. Coolant temperature | Normal running temperature is 75 to 85° C (167 to 185° F). Check and repair the cooling system if temperature is abnormal. |
| 13. Coolant replacement | Change coolant at intervals of 1000 hours or 12 months, whichever comes first. |
| 14. Radiator external face cleaning | Check monthly. Clean at intervals of 250 hours or 3 months, whichever comes first. In very dusty environments, more frequent cleaning might be necessary. |
| 15. Cooling system circuit cleaning | Clean at intervals of 1000 hours or 12 months, whichever comes first. |
| 16. Radiator filling cap function check | Check radiator pressure cap periodically for proper operation. Consult your local Ingersoll Rand branch or distributor. |
| 17. Battery electrolyte level check | Replenish with distilled water if necessary. |
| 18. Battery cleaning | Clean the terminals. |
| 19. Battery charge condition | If cranking speed is too slow to start the engine, charge the battery. |
| 20. Air filter element replacement | Change element at 500 hrs or sooner if the restriction indicator shows red. |
| 21. Cylinder compression pressure | Consult your Ingersoll Rand dealer or distributor. |
| 22. Valve clearance check | Check and adjust every 1000 hours. Consult your Ingersoll Rand dealer or distributor. |

Engine Troubleshooting

This item contains a simple troubleshooting. When a failure takes place on your Ingersoll Rand engine, diagnose the cause referring this troubleshooting. Should the cause of failure not be detected or you are unable to manage the failure, consult your machine supply source or nearest Ingersoll Rand engine service outlet.

Engine does not start.	Starter does not turn.	Battery discharged		
		Bad cable connections.		
		Starter or starter switch failure.		
		Safety relay failure.		
	Starter turns but engine does not fire.	No fuel injection.	Engine stop solenoid malfunction.	
			No fuel in the fuel tank.	
			Clogged fuel filter element.	
			Air in the fuel system.	
			Control rack is stuck at no fuel position.	
		Fuel is injected but engine does not fire.	Incorrect preheating operation.	
Faulty air heater.				
Incorrect injection timing.				
Low cylinder compression pressure.				
Engine stop solenoid not fully returned.				
Engine fires but stalls immediately.	Air in the fuel system.			
	Incorrect low idle speed adjustment.			
Unstable engine running.	Unstable low idling.	Crack in injection pipe.		
		Injection nozzle failure.		
		Engine stop solenoid return failure.		
		Uneven compression pressure between cylinders.		
	Incorrect high idle speed adjustment.	Incorrect control lever adjustment.		
		Governor internal malfunction.		
	Engine hunting in medium speed range.	Governor spring deteriorated.		
	Engine malfunction in high speed range.	Insufficient fuel supply.	Air in the fuel system	
			Clogged fuel filter element	
			Piping failure (squeezed/restricted etc).	
		Uneven fuel injection amount between-cylinders		
		Deteriorated governor spring.		
		Incorrect valve clearance adjustment.		
	Deteriorated valve spring.			
Engine speed stuck at high idle.	Engine control restriction or seizure.			

Engine overheat	Cooling system defect.	Insufficient coolant volume.	
		Fan belt slippage.	
		Thermostat malfunction.	
		Radiator filler cap malfunction.	
		Cooling system interior fouled.	
		Radiator clogged.	
	Improper servicing.	Engine over-loaded.	
		Air cleaner element clogged.	
		Insufficient airflow/restriction.	
Restricted coolant flow (high concentration of antifreeze, etc.).			
Low oil pressure	Lack of oil	Oil leakage.	
		High oil consumption	
	Wrong oil.	Wrong type and viscosity.	
	High coolant temperature.	Over heat.	
	Clogged filter and strainer.		
	Worn bearings and oil pump.		
	Faulty relief valve.		
Low engine output	Incorrect injection pump adjustment.	Incorrect injection timing.	Too far advanced.
			Too far retarded.
		Injection nozzle malfunction.	Incorrect injection pressure.
			Incorrect spray condition.
		Insufficient fuel supply to the injection Pump.	Lack of fuel in tank.
			Air in injection pump.
			Fuel filter clogged.
		Governor malfunction.	Overflow valve malfunction.
	Incorrect engine control adjustment.		
	Low cylinder compression pressure.	Cylinder compression leakage	Incorrect valve clearance adjustment.
			Injector nozzle misalignment.
			Cylinder bore wear.
		Insufficient air intake volume.	Air cleaner clogged.
Restricted air flow.			
Excessive oil consumption	Incorrect oil.	Wrong selection of type and viscosity.	
		Too much oil quantity.	
	Engine burning oil.	Faulty piston rings/damaged cylinder bores.	
		Faulty valve stem seal.	
	Oil leakage.	Damaged seal/Damaged turbocharger seal	
		Loose joints/gaskets.	
		Improper installation of filter and piping.	
Excessive fuel consumption	Fuel leakage.	Damaged seals.	
		Improper component installation or tightening.	
	Excessive injection volume.	Injection pump defective.	
	Excessive mechanical loads.		

Improper exhaust	Excessive black smoke.	Clogged air cleaner.
		Damaged injector nozzle.
		Wrong injector nozzle.
		Injection timing incorrect.
		Excessive injection volume.
		Incorrect fuel.
	Excessive white smoke.	Water mixing in fuel.
		Low compression pressure.
		Injection timing incorrect.
		Low coolant temperature.
Battery over discharge.	Low electrolyte level.	Faulty turbocharger.
		Crack in battery body.
	Charging failure.	Natural consumption.
		Loose or damaged belt.
		Faulty alternator.
	Excessive electrical loads.	Damaged wiring or contact failure.
		Insufficient battery capacity for the application.

*****Always use Ingersoll Rand Replacement parts!*****



Ingersoll Rand Company
Utility Equipment
P.O. Box 868 - 501 Sanford Ave
Mocksville, N.C. 27028